

Appendix 2

Design Demonstration: a Virtual Gallery Scenario

INTRODUCTION

Dynamic design of a virtual gallery is presented in Chapter 6. The virtual gallery scenario comprises eight stages, demonstrating the application of the GDA model and the example grammar. Appendix 2 supplements Chapter 6 by presenting details of the design scenario.

In this appendix, the presentation for each stage of the design scenario has three parts. The first part is a brief description of the stage. The second part presents the application of the example grammar for dynamic design of the virtual gallery in the order of layout rule application, object placement rule application, navigation rule application and interaction rule application. For each design rule application, firstly, the reasoning of the GDA is analysed. The current design goals hypothesised by the GDA and the matched state labels are listed. Secondly, the matched design rules that are applied and the generated virtual gallery design for the stage are presented. The final part of the presentation provides references to the technical implementation of the design scenario. Each stage is implemented in a virtual world developed using Active Worlds¹. The design rules of the example grammar, and a general rule base for supporting the GDA's reasoning, are written using Jess², a rule-based scripting language. The source codes of the implementation are included in the attached CD-ROM. The CD-ROM also includes digital movies with aural narratives that demonstrate dynamic design of the virtual gallery at different stages. More instructions for viewing the content of the CD-ROM can be found in the "readme.txt" file included in the CD-ROM.

STAGE 1: THE ARTIST ENTERS THE VIRTUAL GALLERY

Description

At stage 1, the artist Acosta connects to the virtual world where his virtual gallery is located. Acosta is represented by a GDA in the virtual world. This marks the beginning of the virtual gallery being dynamically designed, implemented and manipulated as needed by Acosta's GDA.

At the moment, Acosta intends to display two new exhibitions: exhibition 1 and 2 in the virtual gallery. In the initial static virtual gallery the GDA senses eight visitors, each of whom are represented by an avatar. On behalf of Acosta, the GDA welcomes the visitors and notifies them that the virtual gallery will be temporarily under construction for arranging new exhibitions. The visitors are reminded that in a very short moment they will be invited and transported to the new exhibitions.

¹ <http://www.activeworlds.com>

² <http://herzberg.ca.sandia.gov/jess>

The GDA meanwhile demolishes the initial static virtual gallery and at the same location places the initial design of the example grammar: the layout of a reception area, to start the design grammar application. According to the exhibition requirements and Acosta's design preferences, the GDA applies the example grammar to provide exhibition spaces for displaying the two exhibitions, and to provide studio spaces for Acosta. After the design of the virtual gallery for stage 1 is implemented, the GDA notifies Acosta and the visitors before transporting Acosta to his personal studio area and the visitors to the gallery areas.

Layout Rule Application

The reasoning of the GDA:

<p>Interpretations of the GDA:</p>	<p>A_{int}:</p> <ul style="list-style-type: none"> • The artist Acosta is present in the virtual gallery. • Acosta intends to display two exhibitions: exhibition 1 and 2. <p>O_{int}:</p> <ul style="list-style-type: none"> • There is no studio space available in the virtual gallery for Acosta. • There is no exhibition space available in the virtual gallery. <p>wA_{int}:</p> <ul style="list-style-type: none"> • The no. of visitors is 8.
<p>Current design goals of the GDA:</p>	<p>1. A_{int}: Acosta is present in the virtual gallery. O_{int}: There is no studio space available in the virtual gallery for Acosta. \rightarrow Design goal $O_{exp}^F=S$ is hypothesised.</p> <p>2. A_{int}: Acosta intends to display exhibition 1. wA_{int}: The no. of visitors is 8, <10. O_{int}: There is no exhibition space available in the virtual gallery. \rightarrow Design goal $O_{exp}^F=g1$ is hypothesised.</p> <p>3. A_{int}: Acosta intends to display exhibition 2. wA_{int}: The no. of visitors is 8, <10. O_{int}: There is no exhibition space available in the virtual gallery. \rightarrow Design goal $O_{exp}^F=g2$ is hypothesised.</p>

The matched state labels (besides $sL=1$):

1. $sL=S$	Because $O_{exp}^F=S$ is hypothesised.
2. $sL=g1$	Because $O_{exp}^F=g1$ is hypothesised.
3. $sL=g2$	Because $O_{exp}^F=g2$ is hypothesised.

Initial design: 

Additive layout rules that are matched and applied at stage 1:

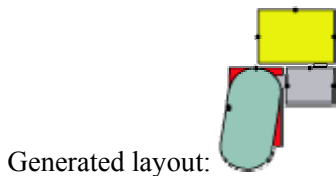
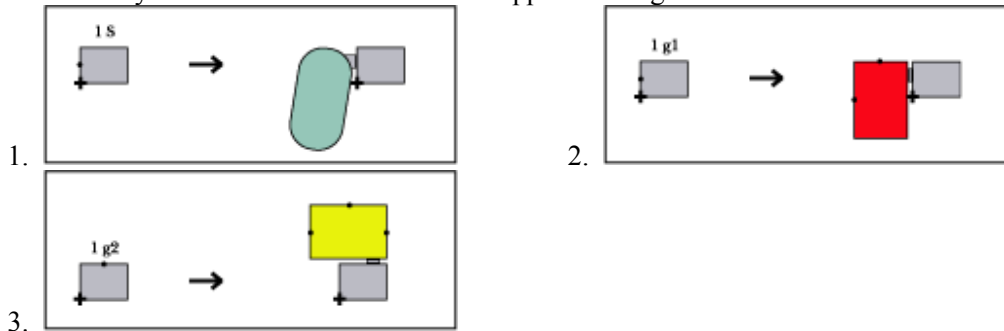

Generated layout:

Object Placement Rule Application

Further reasoning of the GDA:

<p>Interpretations of the GDA:</p>	<p>A_{int}:</p> <ul style="list-style-type: none"> • Acosta prefers cold-colour scheme for the interior of the virtual gallery. • Acosta's exhibitions consist of digital images only and the detail specification is provided. <p>O_{int}:</p> <ul style="list-style-type: none"> • The standard gallery 1 area is currently not arranged. • The standard gallery 2 area is currently not arranged.
<p>Current design goals of the GDA:</p>	<p>1.</p> <p>A_{int}: Acosta prefers cold-colour scheme for the interior of the virtual gallery. \rightarrow Design goal $O_{exp}^F = cC$ is hypothesised.</p> <p>2.</p> <p>A_{int}: Exhibition 1 consists of digital images only. A_{int}: The specification for exhibition 1 matches configuration 1: $a*b+(a-4)/2 < 58m$ and $c < 18m$. O_{int}: The standard gallery 1 area is currently not arranged. \rightarrow Design goal $O_{exp}^F = gIM1$ is hypothesised for the standard gallery 1 area.</p>

	<p>3.</p> <p>A_{int}: Exhibition 2 consists of digital images only.</p> <p>A_{int}: The specification for exhibition 2 matches configuration 1: $a*b+(a-4)/2 < 58m$ and $c < 18m$.</p> <p>O_{int}: The standard gallery 2 area is currently not arranged.</p> <p>→</p> <p>Design goal $O_{exp}^F = gIM1$ is hypothesised for the standard gallery 2 area.</p>
--	---

Additional state labels matched for the object placement rule application (besides $sL=2$):

1. $sL=cC$	Because $O_{exp}^F=cC$ is hypothesised.
2. $sL=gIM1$	Because $O_{exp}^F=gIM1$ is hypothesised.

Additive placement rules that are matched and applied at stage 1:

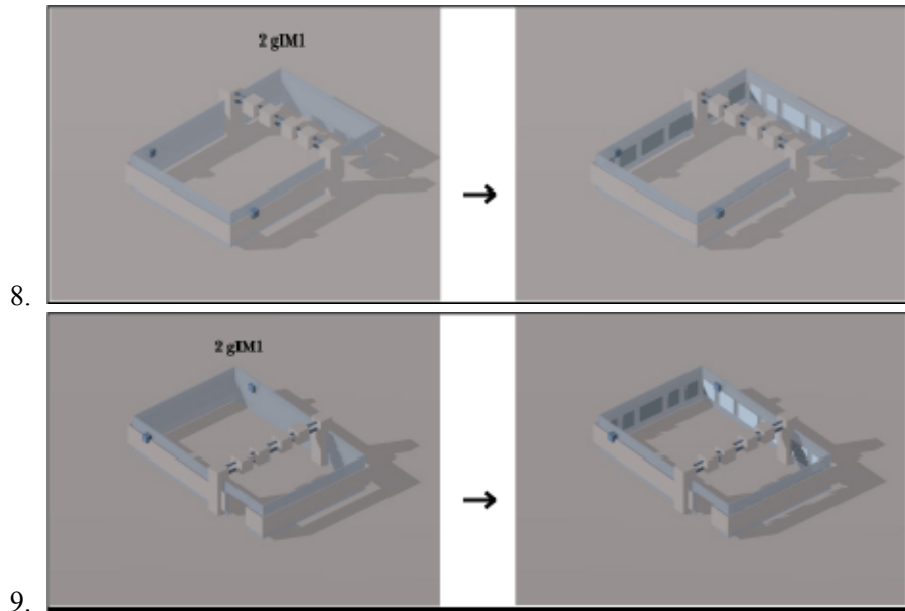
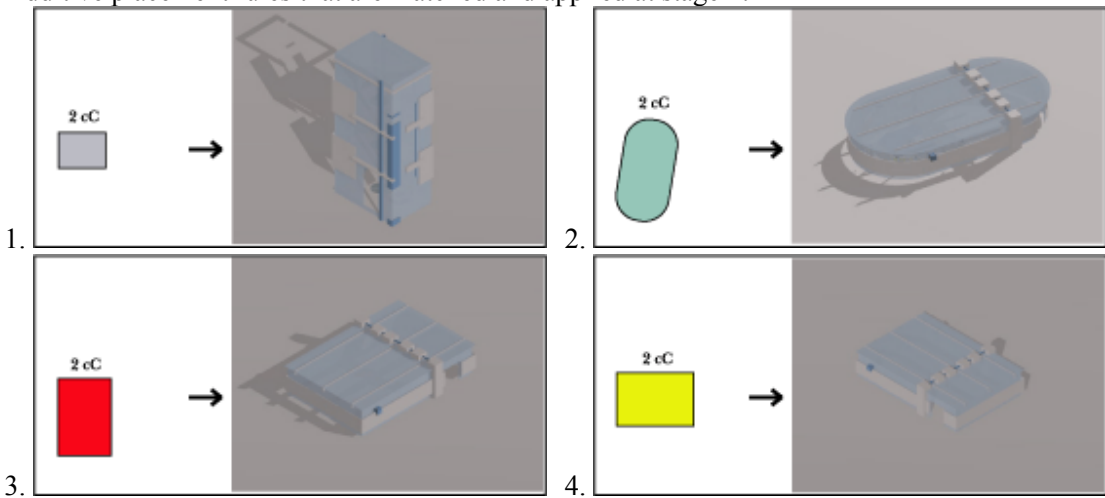

3D visualisation of the virtual gallery design for stage 1:

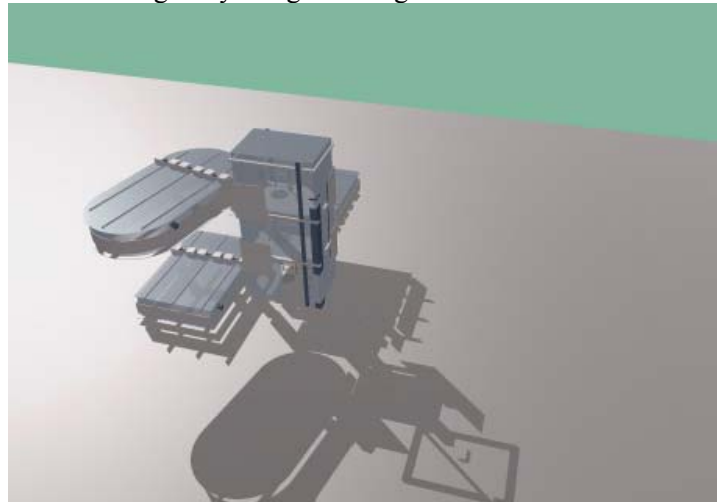

Navigation Rule Application

Additive navigation rules that are matched and applied at stage 1:

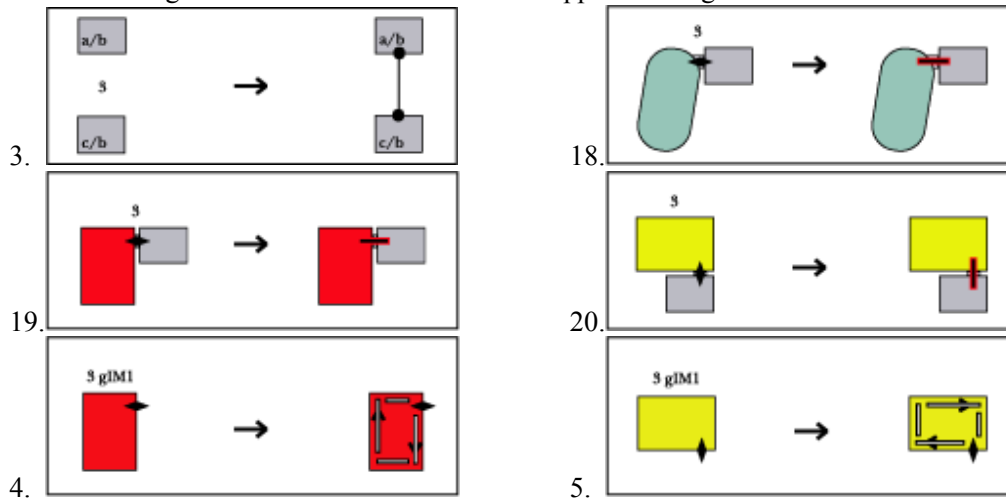

Result of the navigation rule application:

1. In the reception area: floor 1 connects to floor 2 via a pair of hyperlink portals (warp).
2. In the reception area: floor 1 connects to floor 3 via a pair of hyperlink portals (warp).
3. In the reception area: floor 2 connects to floor 3 via a pair of hyperlink portals (warp).
4. A path is laid between the reception area and Acosta's personal studio area.
5. A path is laid between the reception area and the standard gallery 1 area.
6. A path is laid between the reception area and the standard gallery 2 area.
7. Paths are laid in the standard gallery 1 area for guiding visitors in exhibition 1.
8. Paths are laid in the standard gallery 2 area for guiding visitors in exhibition 2.

Interaction Rule Application

Additive interaction rules that are matched and applied at stage 1:

<p>1.</p> <p>sL=4</p> <p>IF: The 3D model of a digital picture frame object is recognised within a gallery area.</p> <p>AND</p> <p>The digital picture frame object is currently not configured.</p> <p>THEN: Render the appropriate digital image onto the surface of the 3D model from the artist's exhibition.</p> <p>AND</p> <p>Enable the digital image to be enlarged and accessed from the web browser.</p>
<p>3.</p> <p>sL=4</p> <p>IF: The 3D model of a digital document object is recognised within a reception area, the artist's personal studio area, or the multi-function area.</p> <p>AND</p> <p>The digital document object is currently not configured.</p> <p>THEN: Attach the relevant digital information to the object.</p> <p>AND</p> <p>Enable the detail of the information to be accessed from the web browser.</p>
<p>6.</p> <p>sL=4</p> <p>IF: The 3D models of a pair of hyperlink portals (warp) are recognised connecting two different floors of a reception area.</p> <p>AND</p> <p>The portals are currently not configured.</p> <p>THEN: Detect the coordinates of the portals.</p> <p>AND</p> <p>Detect any obstacle between these two locations.</p> <p>IF: No obstacle exists.</p> <p>THEN: Activate the portals using the detected coordinates.</p> <p>IF: Any obstacle exists.</p> <p>THEN: Change the hyperlink portals (from warp to teleport).</p> <p>AND</p> <p>Activate the portals using the detected coordinates.</p>

Result of the interaction rule application:

<p>1. In the standard gallery 1 area: exhibition 1 is displayed using various digital picture frame objects in the area.</p>
<p>2. In the standard gallery 2 area: exhibition 2 is displayed using various digital picture frame objects in the area.</p>
<p>3. In the reception area: information about the virtual gallery and the exhibitions is provided using various digital document objects in the area.</p>
<p>4. In the artist's personal studio area: the artist's digital tools and data are stored using various digital document objects in the area.</p>
<p>5. In the reception area: hyperlink portals (warp) that connect different floors of the area are activated.</p>

Technical Implementation

Design rules that are matched and applied at stage 1: (from the attached CD-ROM) demo\grammar\design_rule1.clp ³
A general rule base that supports the GDA's reasoning at stage 1: (from the attached CD-ROM) demo\agent\general_rule1.clp ³
A digital movie that demonstrates dynamic design of the virtual gallery at stage 1: (from the attached CD-ROM) demo\movie\stage1.avi ³

Implementation of the virtual gallery design in Active Worlds:

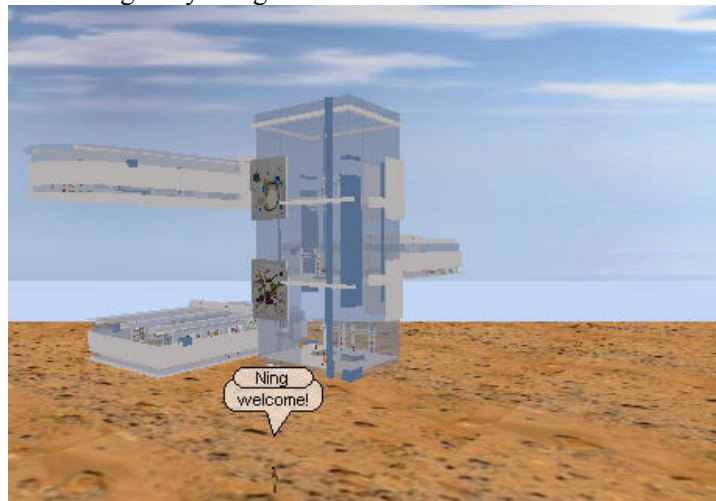

STAGE 2: EXHIBITION 1 ATTRACTS MORE VISITORS

Description

At stages 2 more visitors connect to the virtual world and visit the virtual gallery. At one point, the number of visitors in the standard gallery 1 area increases to 10. This reaches the maximum capacity of a standard gallery area⁴. Acosta's GDA senses this change and applies the example grammar to add an additional gallery area for displaying exhibition 1. Any future visitors who wish to visit exhibition 1 will be automatically transported to this newly generated gallery area until the number of visitors in the original gallery area drops below 10.

During the application of the example grammar the GDA encounters a situation where there are multiple layout rules that satisfy the search criteria. The layout of the virtual gallery can be expanded either along the X axis or along the Y axis. The GDA turns to Acosta for instructions. Acosta prefers to expand the layout along the Y axis. The GDA follows the instructions and continues the grammar application.

³ “.clp” files can be opened using text editing software; for example, Notepad, WordPad and Microsoft Word. The digital movies are in standard “.avi” format and can be played using common media players. Please use speakers to hear the narrative of each movie.

⁴ As discussed in Chapter 5 section 5.3, for this example grammar a gallery area has two different sizes and the maximum number of visitors in a gallery area is set to be 10 for the comfort of the visitors' viewing and the ease of their movements in the area. In the future, these restrictions can be addressed with the use of a parametric grammar.

Layout Rule Application

The reasoning of the GDA:

Interpretations of the GDA:	O_{int} : <ul style="list-style-type: none"> The additional standard gallery 1 area has no connected reception area. wA_{int} : <ul style="list-style-type: none"> The number of visitors in the standard gallery 1 area is 10.
Current design goals of the GDA:	<ol style="list-style-type: none"> wA_{int}: The number of visitors in the standard gallery 1 area is 10. \rightarrow Design goal $O_{exp}^F=g1+$ is hypothesised. O_{int}: The additional standard gallery 1 area has no connected reception area. \rightarrow Design goal $O_{exp}^F=r+$ is hypothesised.

The matched state labels (besides $sL=1$):

1. $sL=g1+$	Because $O_{exp}^F=g1+$ is hypothesised.
2. $sL=r+$	Because $O_{exp}^F=r+$ is hypothesised.

Additive layout rules that satisfy the search criteria:

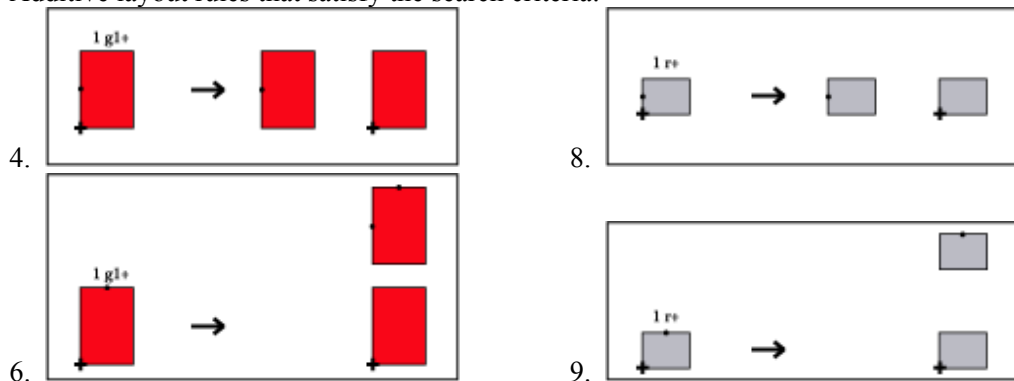

Layout rules that are selected by the artist from above for application at stage 2:

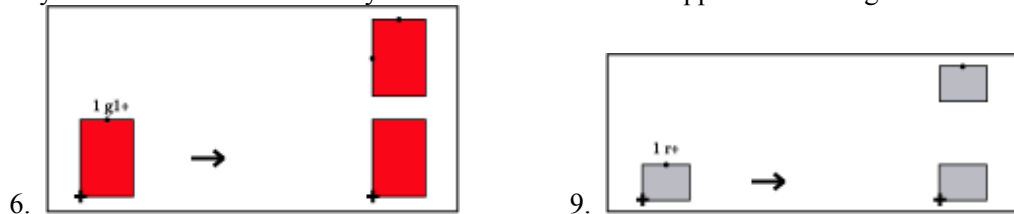

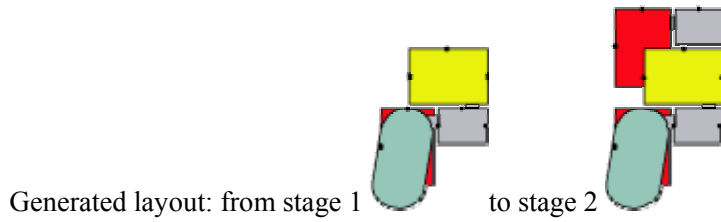

Object Placement Rule Application

Further reasoning of the GDA:

<p>Interpretations of the GDA:</p>	<p>A_{int}:</p> <ul style="list-style-type: none"> Acosta prefers cold-colour scheme for the interior of the virtual gallery. Acosta's exhibitions consist of digital images only and the detail specification is provided. <p>O_{int}:</p> <ul style="list-style-type: none"> The additional standard gallery 1 area is currently not arranged.
<p>Current design goals of the GDA:</p>	<p>1.</p> <p>A_{int}: Acosta prefers cold-colour scheme for the interior of the virtual gallery. \rightarrow Design goal $O_{exp}^F = cC$ is hypothesised.</p> <p>2.</p> <p>A_{int}: Exhibition 1 consists of digital images only. A_{int}: The specification for exhibition 1 matches configuration 1: $a*b+(a-4)/2 < 58m$ and $c < 18m$. O_{int}: The additional standard gallery 1 area is currently not arranged. \rightarrow Design goal $O_{exp}^F = gIM1$ is hypothesised.</p>

Additional state labels matched for the object placement rule application (besides $sL=2$):

1. $sL=cC$	Because $O_{exp}^F = cC$ is hypothesised.
2. $sL=gIM1$	Because $O_{exp}^F = gIM1$ is hypothesised.

Additive placement rules that are matched and applied at stage 2:

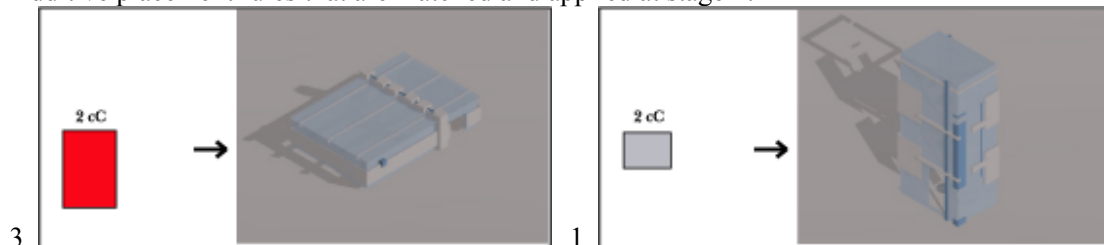

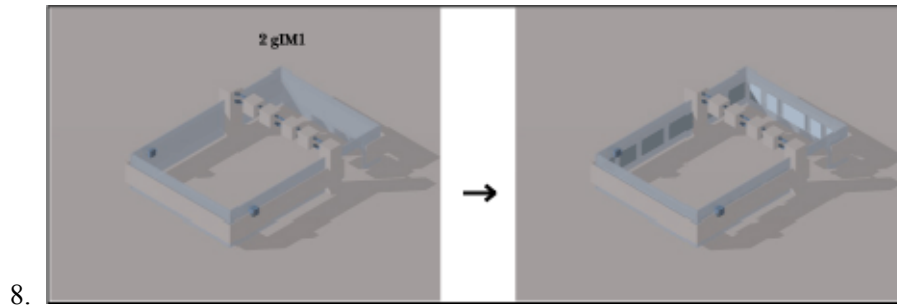

3D visualisation of the virtual gallery design for stage 2:

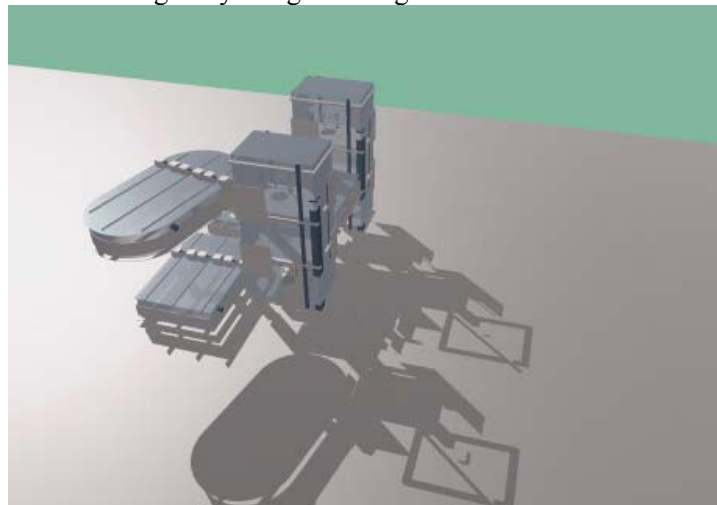

Navigation Rule Application

Additive navigation rules that are matched and applied at stage 2:

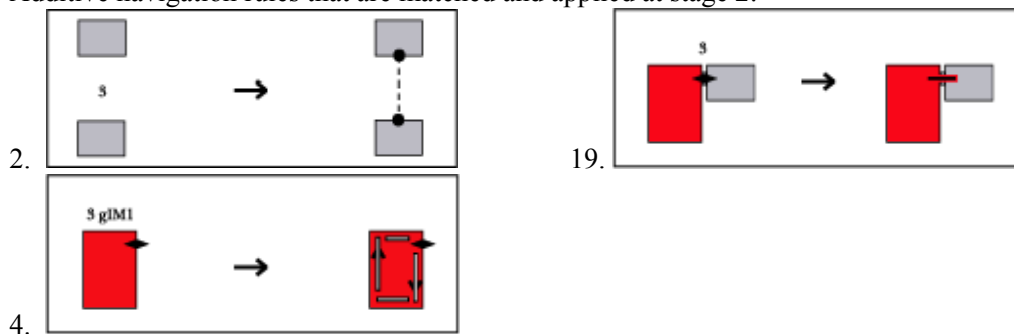

Result of the navigation rule application:

- | |
|--|
| 1. The two reception areas connect to each other via a pair of hyperlink portals (teleport). |
| 2. A path is laid between the additional standard gallery 1 area and its connected reception area. |
| 3. Paths are laid in the additional standard gallery 1 area for guiding visitors in exhibition 1. |

Interaction Rule Application

Additive interaction rules that are matched and applied at stage 2:

1. sL=4 IF: The 3D model of a digital picture frame object is recognised within a gallery area. AND The digital picture frame object is currently not configured. THEN: Render the appropriate digital image onto the surface of the 3D model from the artist's exhibition. AND Enable the digital image to be enlarged and accessed from the web browser.
3. sL=4 IF: The 3D model of a digital document object is recognised within a reception area, the artist's personal studio area, or the multi-function area. AND The digital document object is currently not configured. THEN: Attach the relevant digital information to the object. AND Enable the detail of the information to be accessed from the web browser.
5. sL=4 IF: The 3D models of a pair of hyperlink portals (teleport) are recognised connecting two reception areas. AND The portals are currently not configured. THEN: Detect the coordinates of the portals. AND Activate the portals using the detected coordinates.

Result of the interaction rule application:

1. In the additional standard gallery 1 area: exhibition 1 is displayed using various digital picture frame objects in the area.
2. In the additional reception area: information about the virtual gallery and the exhibitions is provided using various digital document objects in the area.
3. In both reception areas: hyperlink portals (teleport) that connect the two areas are activated.

Technical Implementation

Design rules that are matched and applied at stage 2: (from the attached CD-ROM) demo\grammar\design_rule2.clp ⁵
A general rule base that supports the GDA's reasoning at stage 2: (from the attached CD-ROM) demo\agent\general_rule2.clp ⁵
A digital movie that demonstrates dynamic design of the virtual gallery at stage 2: (from the attached CD-ROM) demo\movie\stage2.avi ⁵

⁵ “.clp” files can be opened using text editing software; for example, Notepad, WordPad and Microsoft Word. The digital movies are in standard “.avi” format and can be played using common media players. Please use speakers to hear the narrative of each movie.

Implementation of the virtual gallery design in Active Worlds:

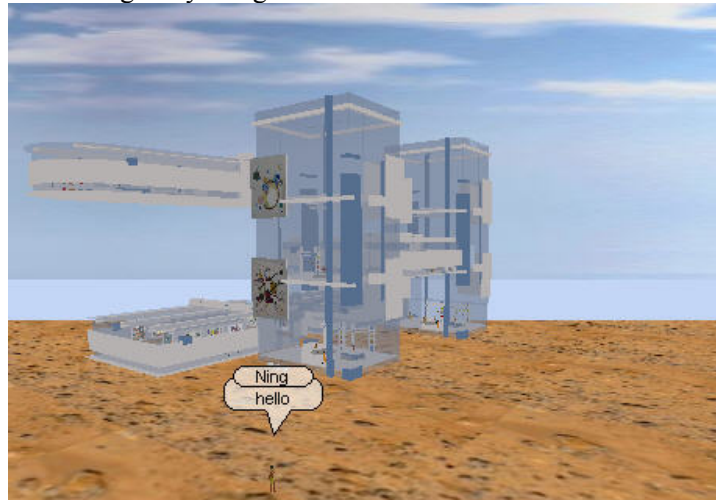

STAGE 3: AN INVITED GUEST ENTERS THE VIRTUAL GALLERY

Description

Acosta is browsing some digital information in his personal studio area. He instructs his GDA to organise a meeting venue for him and his guest Sumi, who will be arriving in the virtual gallery soon. The GDA applies the example grammar to arrange a meeting area inside Acosta's personal studio area. When Sumi connects to the virtual world, the GDA welcomes her on behalf of Acosta and transports her directly to the newly generated meeting area.

Layout Rule Application

No layout rule is applied at stage 3.

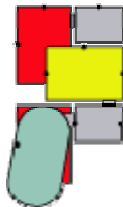

Layout is the same as at stage 2

Object Placement Rule Application

The reasoning of the GDA:

Interpretations of the GDA:	A_{int} : <ul style="list-style-type: none"> Acosta requests a meeting venue for two persons. O_{int} : <ul style="list-style-type: none"> There is no meeting venue available in the virtual gallery.
Current design goal of the GDA:	1. <ul style="list-style-type: none"> A_{int}: Acosta requests a meeting venue for two persons. O_{int}: There is no meeting venue available in the virtual gallery. \rightarrow Design goal $O_{exp}^F = mS$ is hypothesised.

The matched state label (besides $sL=2$):

1. $sL=mS$	Because $O_{exp}^F=mS$ is hypothesised.
------------	---

The additive placement rule that is matched and applied at stage 3:

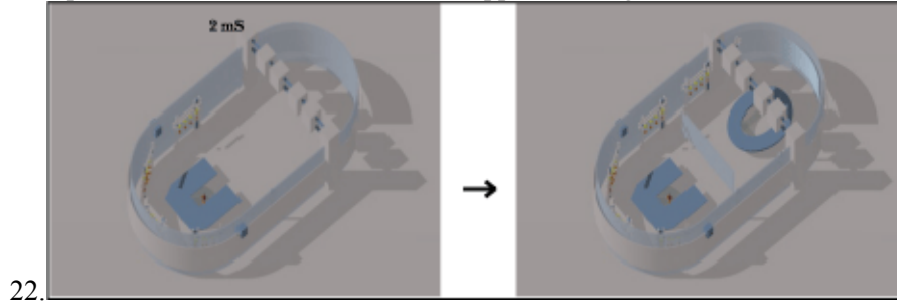

3D visualisation of the virtual gallery design for stage 3:

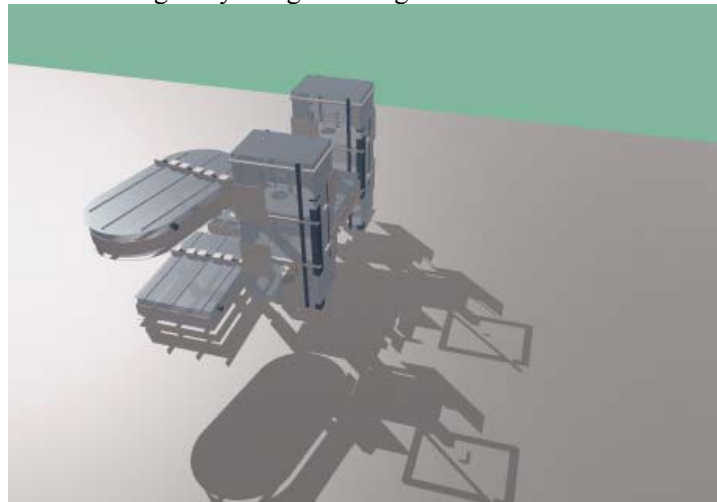

Navigation Rule Application

No navigation rule is applied at stage 3.

Interaction Rule Application

The additive interaction rule that is matched and applied at stage 3:

4. $sL=4$ IF: A 3D model of a digital projector object is recognised in the multi-function area or the artist's personal studio area. AND The digital projector object is currently not configured. THEN: Load the conference/meeting materials to the object for presentation.
--

Result of the interaction rule application:

1. In the meeting area (configured in the artist's personal studio area): the meeting materials are loaded to the digital projector object.

Technical Implementation

Design rules that are matched and applied at stage 3: (from the attached CD-ROM) demo\grammar\design_rule3.clp ⁶
A general rule base that supports the GDA's reasoning at stage 3: (from the attached CD-ROM) demo\agent\general_rule3.clp ⁶
A digital movie that demonstrates dynamic design of the virtual gallery at stage 3: (from the attached CD-ROM) demo\movie\stage3.avi ⁶

Implementation of the virtual gallery design in Active Worlds:

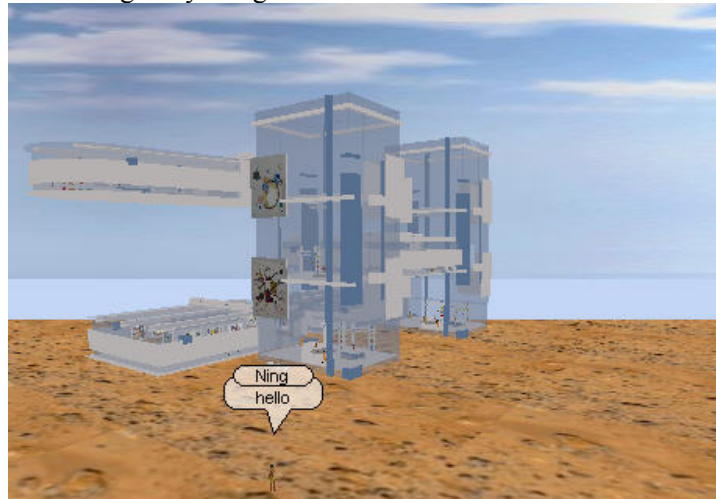

STAGE 4: THE ARTIST DECIDES TO GIVE A PUBLIC TALK

Description

At stage 4 Acosta decides to give a public talk to highlight the current exhibitions, after the meeting with Sumi. He instructs his GDA to organise a venue for the public function. The GDA applies the example grammar to generate the multi-function area in the virtual gallery, and arrange the area as a conference venue. After Acosta finishes the preparation for the talk, the GDA sends an invitation to the visitors on behalf of Acosta, and transports those who accept the invitation to the multi-function area.

Layout Rule Application

The reasoning of the GDA:

Interpretations of the GDA:	A_{int} : <ul style="list-style-type: none"> Acosta requests a conference venue for a large crowd. O_{int} : <ul style="list-style-type: none"> There is no conference venue available in the virtual gallery.
Current design	<ol style="list-style-type: none"> 1. A_{int}: Acosta requests a conference venue for a large crowd > 10.

⁶ “.clp” files can be opened using text editing software; for example, Notepad, WordPad and Microsoft Word. The digital movies are in standard “.avi” format and can be played using common media players. Please use speakers to hear the narrative of each movie.

goal of the GDA:	O_{int} : There is no conference venue available in the virtual gallery. → Design goal $O_{exp}^F=mC$ is hypothesised.
------------------	--

The matched state label (besides $sL=1$):

1. $sL=mC$	Because $O_{exp}^F=mC$ is hypothesised.
------------	---

The additive layout rule that is matched and applied at stage 4:

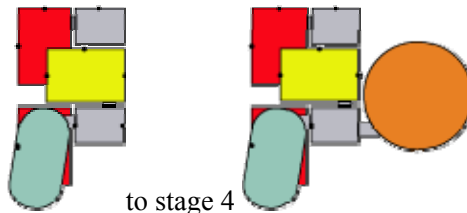
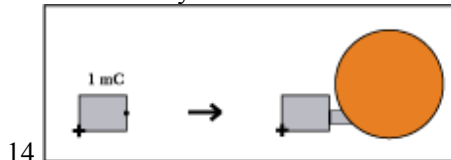

Generated layout: from stage 3 to stage 4

Object Placement Rule Application

Further reasoning of the GDA:

Interpretations of the GDA:	A_{int} : <ul style="list-style-type: none"> Acosta prefers cold-colour scheme for the interior of the virtual gallery. O_{int} : <ul style="list-style-type: none"> The multi-function area is currently not arranged.
Current design goals of the GDA:	1. A_{int} : Acosta prefers cold-colour scheme for the interior of the virtual gallery. → Design goal $O_{exp}^F=cC$ is hypothesised. 2. A design goal $O_{exp}^F=mC$ was previously hypothesised. O_{int} : The multi-function area is currently not arranged. → Design goal $O_{exp}^F=mMc$ is hypothesised.

Additional state labels matched for the object placement rule application (besides $sL=2$):

1. $sL=cC$	Because $O_{exp}^F=cC$ is hypothesised.
2. $sL=mMc$	Because $O_{exp}^F=mMc$ is hypothesised.

Additive placement rules that are matched and applied at stage 4:

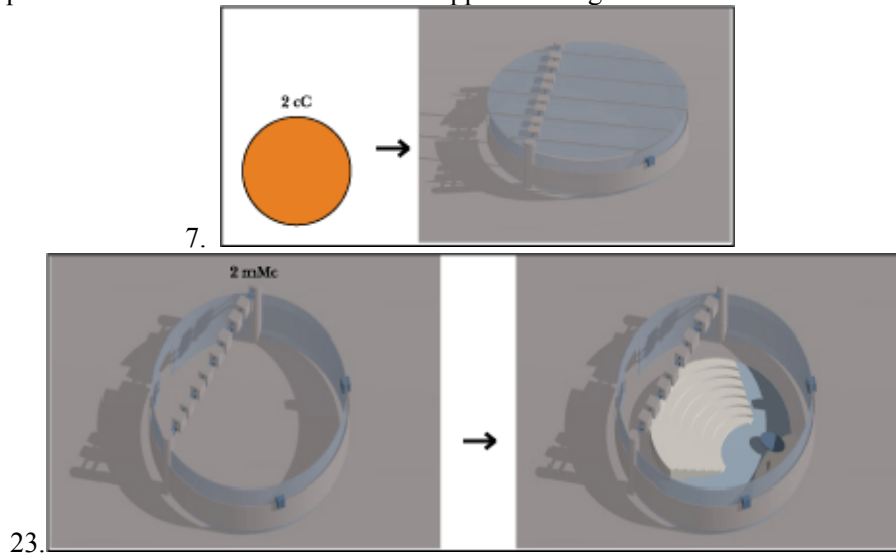

3D visualisation of the virtual gallery design for stage 4:

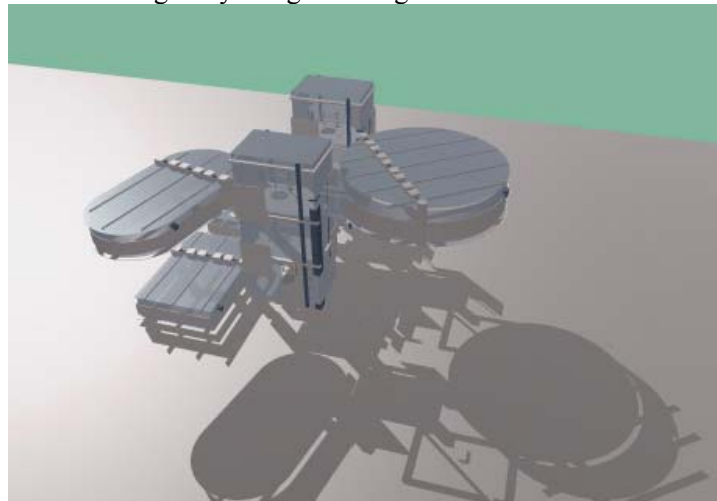

Navigation Rule Application

The additive navigation rule that is matched and applied at stage 4:

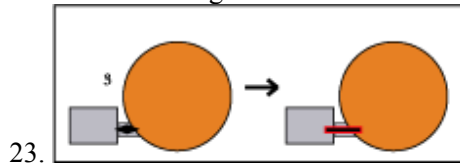

Result of the navigation rule application:

1. A path is laid between the multi-function area and its connected reception area.

Interaction Rule Application

The additive interaction rule that is matched and applied at stage 4:

4. sL=4 IF: A 3D model of a digital projector object is recognised in the multi-function area or the artist's personal studio area. AND The digital projector object is currently not configured. THEN: Load the conference/meeting materials to the object for presentation.
--

Result of the interaction rule application:

1. In the multi-function area: Acosta's presentation materials are loaded to the digital projector object.
--

Technical Implementation

Design rules that are matched and applied at stage 4: (from the attached CD-ROM) demo\grammar\design_rule4.clp ⁷
A general rule base that supports the GDA's reasoning at stage 4: (from the attached CD-ROM) demo\agent\general_rule4.clp ⁷
A digital movie that demonstrates dynamic design of the virtual gallery at stage 4: (from the attached CD-ROM) demo\movie\stage4.avi ⁷

Implementation of the virtual gallery design in Active Worlds:

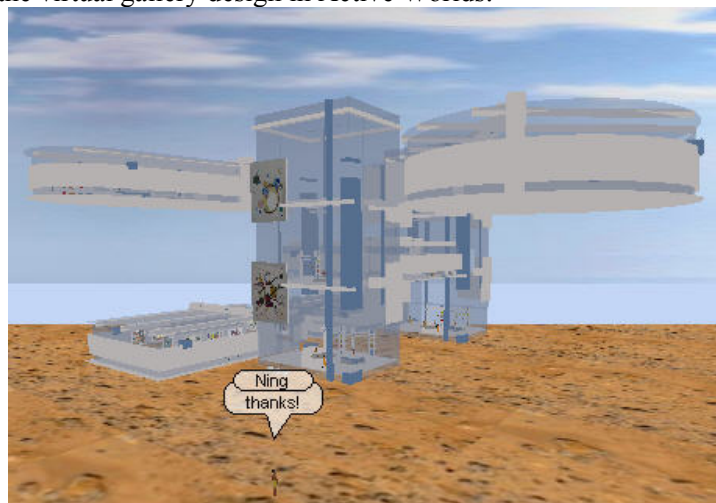

STAGE 5: EXHIBITION 2 ATTRACTS MORE VISITORS

Description

After the talk some visitors remain in the multi-function area for discussion with Acosta. The rest return to the exhibitions. At one point the number of visitors in the standard gallery 2 area

⁷ “.clp” files can be opened using text editing software; for example, Notepad, WordPad and Microsoft Word. The digital movies are in standard “.avi” format and can be played using common media players. Please use speakers to hear the narrative of each movie.

increases to 10. This reaches the maximum capacity of a standard gallery area⁸. Acosta's GDA senses this change and applies the example grammar to add an additional gallery area for displaying exhibition 2. Any future visitors who wish to visit exhibition 2 will be automatically transported to this newly generated gallery area until the number of visitors in the original gallery area drops below 10.

Similar to stage 2, during the application of the example grammar the GDA encounters a situation where there are multiple layout rules that satisfy the search criteria. The layout of the virtual gallery can be expanded either along the X axis or along the Y axis. The GDA turns to Acosta for instructions. Acosta prefers to expand the layout along the Y axis. The GDA follows the instructions and continues the grammar application.

Layout Rule Application

The reasoning of the GDA:

Interpretations of the GDA:	wA_{int} : <ul style="list-style-type: none"> The number of visitors in the standard gallery 2 area is 10.
Current design goal of the GDA:	1. wA_{int} : The number of visitors in the standard gallery 2 area is 10. → Design goal $O_{exp}^F = g2+$ is hypothesised.

The matched state label (besides $sL=1$):

1. $sL=g2+$	Because $O_{exp}^F = g2+$ is hypothesised.
-------------	--

Additive layout rules that satisfy the search criteria:

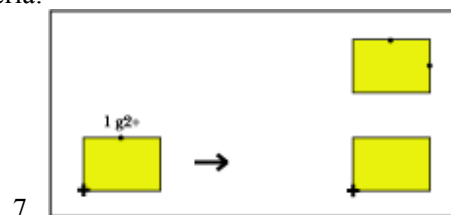
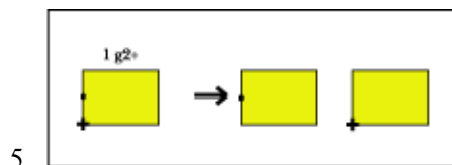

The layout rule that is selected by the artist from above for application at stage 5:

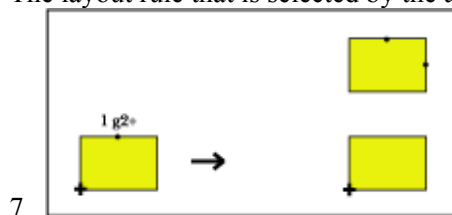

⁸ As discussed in Chapter 5 section 5.3, for this example grammar a gallery area has two different sizes and the maximum number of visitors in a gallery area is set to be 10 for the comfort of the visitors' viewing and the ease of their movements in the area. In the future, these restrictions can be addressed with the use of a parametric grammar.

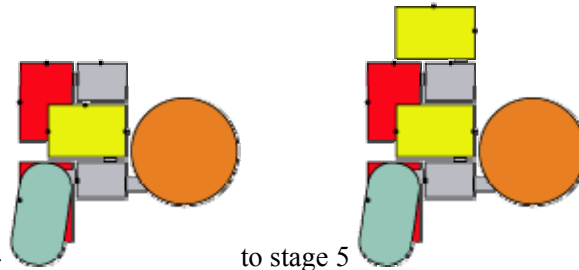

Generated layout: from stage 4

to stage 5

Object Placement Rule Application

Further reasoning of the GDA:

<p>Interpretations of the GDA:</p>	<p>A_{int}:</p> <ul style="list-style-type: none"> Acosta prefers cold-colour scheme for the interior of the virtual gallery. Acosta's exhibitions consist of digital images only and the detail specification is provided. <p>O_{int}:</p> <ul style="list-style-type: none"> The additional standard gallery 2 area is currently not arranged.
<p>Current design goals of the GDA:</p>	<p>1. A_{int}: Acosta prefers cold-colour scheme for the interior of the virtual gallery. \rightarrow Design goal $O_{exp}^F = cC$ is hypothesised.</p> <p>2. A_{int}: Exhibition 2 consists of digital images only. A_{int}: The specification for exhibition 1 matches configuration 1: $a*b+(a-4)/2 < 58m$ and $c < 18m$. O_{int}: The additional standard gallery 2 area is currently not arranged. \rightarrow Design goal $O_{exp}^F = gIM1$ is hypothesised.</p>

Additional state labels matched for the object placement rule application (besides $sL=2$):

<p>1. $sL=cC$</p>	<p>Because $O_{exp}^F = cC$ is hypothesised.</p>
<p>2. $sL=gIM1$</p>	<p>Because $O_{exp}^F = gIM1$ is hypothesised.</p>

Additive placement rules that are matched and applied at stage 5:

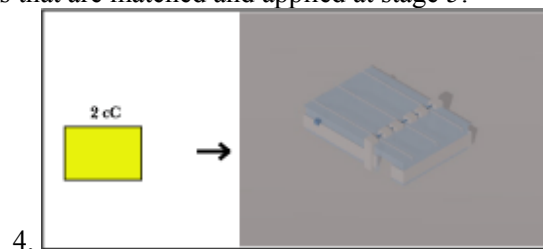

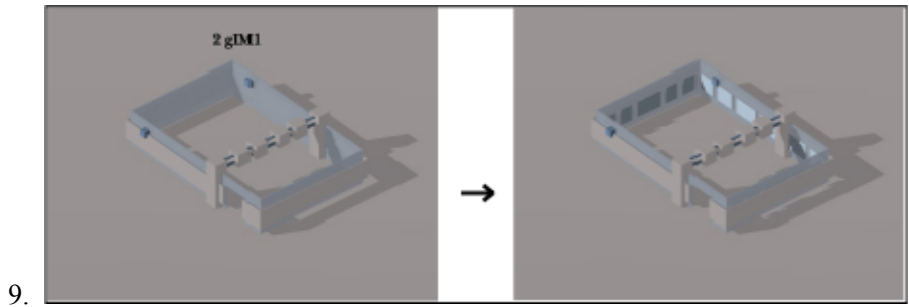

3D visualisation of the virtual gallery design for stage 5:

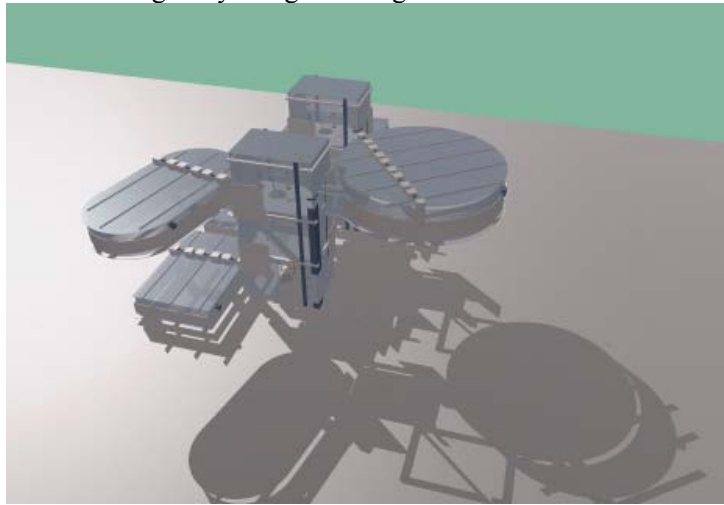

Navigation Rule Application

Additive navigation rules that are matched and applied at stage 5:

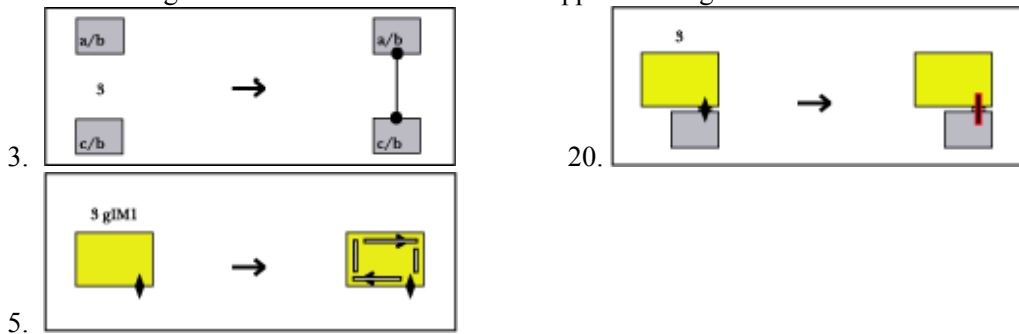

Result of the navigation rule application:

- | |
|--|
| 1. A path is laid between the additional generated standard gallery 2 area and its connected reception area. |
| 2. Paths are laid in the additional standard gallery 2 area for guiding visitors in exhibition 2. |
| 3. In the additional reception area: floor 1 connects to floor 2 via a pair of hyperlink portals (warp). |

Interaction Rule Application

Additive interaction rules that are matched and applied at stage 5:

1. sL=4 IF: The 3D model of a digital picture frame object is recognised within a gallery area. AND The digital picture frame object is currently not configured. THEN: Render the appropriate digital image onto the surface of the 3D model from the artist's exhibition. AND Enable the digital image to be enlarged and accessed from the web browser.
6. sL=4 IF: The 3D models of a pair of hyperlink portals (warp) are recognised connecting two different floors of a reception area. AND The portals are currently not configured. THEN: Detect the coordinates of the portals. AND Detect any obstacle between these two locations. IF: No obstacle exists. THEN: Activate the portals using the detected coordinates. IF: Any obstacle exists. THEN: Change the hyperlink portals (from warp to teleport). AND Activate the portals using the detected coordinates.

Result of the interaction rule application:

1. In the additional standard gallery 2 area: exhibition 2 is displayed using various digital picture frame objects in the area.
2. In the additional reception area: hyperlink portals (warp) that connect different floors of the reception area are activated.

Technical Implementation

Design rules that are matched and applied at stage 5: (from the attached CD-ROM) demo\grammar\design_rule5.clp ⁹
A general rule base that supports the GDA's reasoning at stage 5: (from the attached CD-ROM) demo\agent\general_rule5.clp ⁹
A digital movie that demonstrates dynamic design of the virtual gallery at stage 5: (from the attached CD-ROM) demo\movie\stage5.avi ⁹

⁹ “.clp” files can be opened using text editing software; for example, Notepad, WordPad and Microsoft Word. The digital movies are in standard “.avi” format and can be played using common media players. Please use speakers to hear the narrative of each movie.

Implementation of the virtual gallery design in Active Worlds:

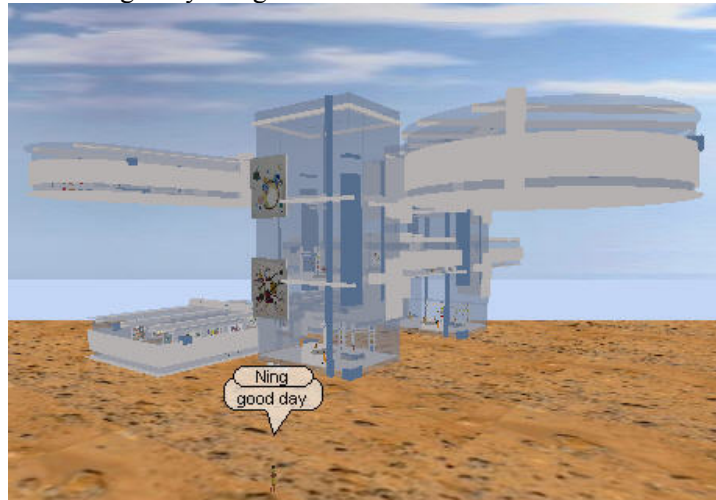

STAGE 6: THE ARTIST CHANGES EXHIBITION 2

Description

At stage 6 Acosta returns to his personal studio area. He decides to modify exhibition 2 by adding more exhibition items, including more digital images and some interactive installations. Acosta instructs his GDA to accommodate the changes. On behalf of Acosta the GDA informs the visitors about the changes and applies the example grammar to expand and rearrange both gallery 2 areas in order to display the new exhibition 2.

Layout Rule Application

The reasoning of the GDA:

Interpretations of the GDA:	A_{int} : <ul style="list-style-type: none"> The artist requests to display more items in exhibition 2. O_{int} : <ul style="list-style-type: none"> The two gallery areas for displaying exhibition 2 each have a standard size.
Current design goal of the GDA:	1. <ul style="list-style-type: none"> A_{int}: The artist requests to display more items in exhibition 2. O_{int}: The two gallery areas for displaying exhibition 2 each have a standard size. → <ul style="list-style-type: none"> Design goal $O_{exp}^F = gE2$ is hypothesised.

The matched state label (besides $sL=1$):

1. $sL=gE2$	Because $O_{exp}^F = gE2$ is hypothesised.
-------------	--

Additive layout rules that are matched and applied at stage 6:

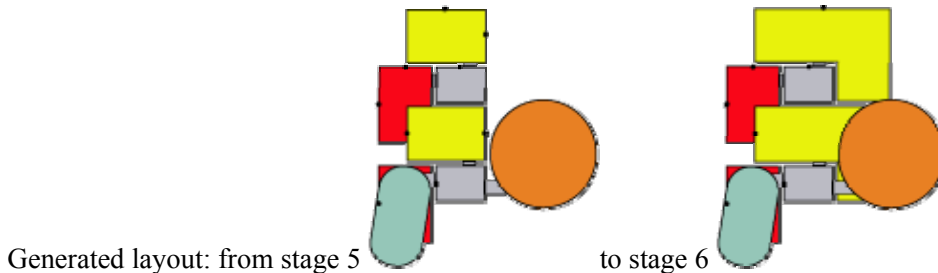
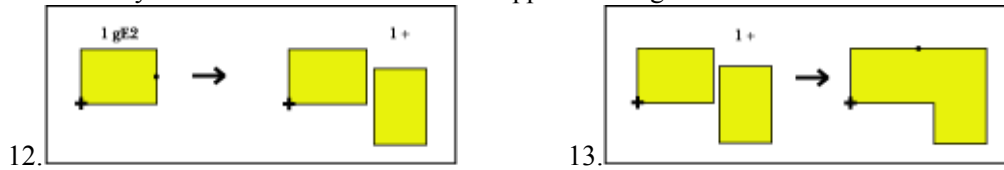

Object Placement Rule Application

Further reasoning of the GDA:

Interpretations of the GDA:	<p>A_{int}:</p> <ul style="list-style-type: none"> Acosta prefers cold-colour scheme for the interior of the virtual gallery. Acosta's new exhibition 2 consists of both digital images and interactive installations and the detail specification is provided. <p>O_{int}:</p> <ul style="list-style-type: none"> The expanded gallery 2 areas are currently not arranged.
Current design goals of the GDA:	<ol style="list-style-type: none"> <p>A_{int}: The artist changes exhibition 2.</p> <p>→</p> <p>Design goal $O_{exp}^F = g2-$ is hypothesised.</p> <p>A_{int}: Acosta prefers cold-colour scheme for the interior of the virtual gallery.</p> <p>→</p> <p>Design goal $O_{exp}^F = cC$ is hypothesised.</p> <p>A_{int}: The new exhibition 2 consists of both digital images and interactive installations.</p> <p>A_{int}: The specification for exhibition 1 matches configuration 7: $a*b+(a-8)/2 < 81m$ and $c < 20m$, and $d*e+(d-1) < 21m$, $f < 21m$, $g < 9m$ and $h < 6m$.</p> <p>O_{int}: The expanded gallery 2 areas are currently not arranged.</p> <p>→</p> <p>Design goal $O_{exp}^F = gIMS$ is hypothesised.</p>

Additional state labels matched for the object placement rule application (besides $sL=2$):

1. $sL=g2-$	Because $O_{exp}^F = g2-$ is hypothesised.
2. $sL=cC$	Because $O_{exp}^F = cC$ is hypothesised.

3. sL=gIMS	Because $O_{exp}^F=gIMS$ is hypothesised.
------------	---

The subtractive placement rule that is matched and applied at stage 6:

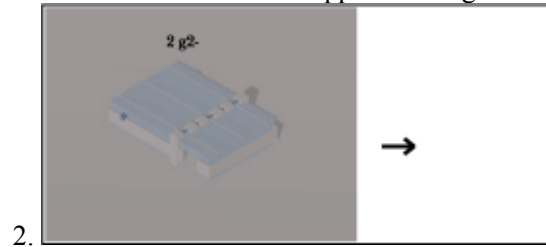

Additive placement rules that are matched and applied at stage 6:

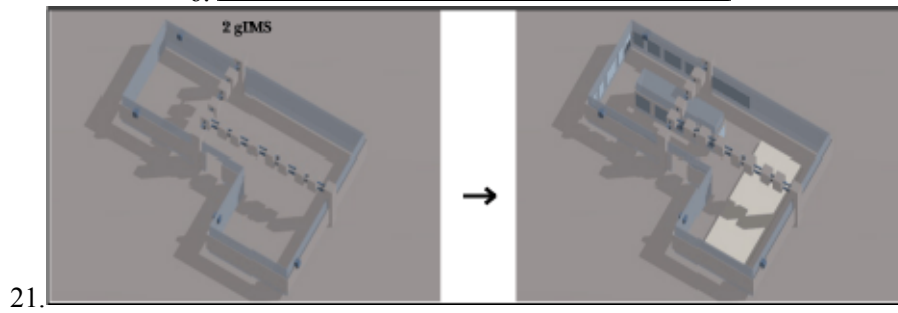
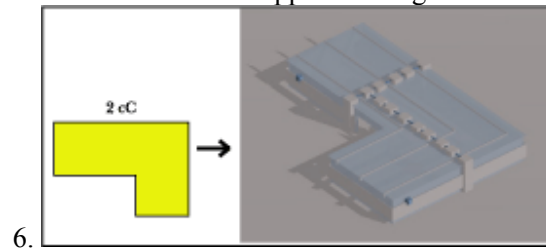

3D visualisation of the virtual gallery design for stage 6:

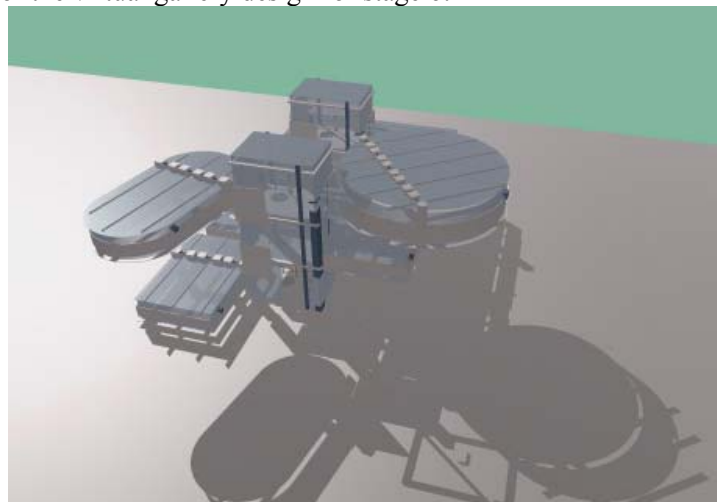

Navigation Rule Application

Subtractive navigation rules that are matched and applied at stage 6:

3.	<p>sL=3 IF: A path is laid in a gallery area for guiding visitors in an exhibition. AND The layout of the gallery area changes. AND/OR The visual boundaries of the gallery area change. THEN: Remove the path.</p>
5.	<p>sL=3 IF: A path connects a reception area with a gallery area. AND The reception area is not sensed in the virtual gallery. AND/OR The gallery area is not sensed in the virtual gallery. THEN: Remove the path.</p>

Additive navigation rules that are matched and applied at stage 6:



Result of the navigation rule application:

1. The paths that connect the standard gallery 2 areas with their connected reception areas are removed.
2. Paths laid in the standard gallery 2 areas are removed.
3. A path is laid between each expanded gallery 2 area and the connected reception area.
4. Paths are laid in each expanded gallery 2 area for guiding visitors in the new exhibition 2.

Interaction Rule Application

Additive interaction rules that are matched and applied at stage 6:

1.	<p>sL=4 IF: The 3D model of a digital picture frame object is recognised within a gallery area. AND The digital picture frame object is currently not configured. THEN: Render the appropriate digital image onto the surface of the 3D model from the artist's exhibition. AND Enable the digital image to be enlarged and accessed from the web browser.</p>
2.	<p>sL=4 IF: The 3D model of an object that forms a part of an interactive installation is recognised within a gallery area or the multi-function area. AND The object is currently not configured.</p>

THEN: Ascribe appropriate behaviours to the object according to the artist's exhibition requirements.

Result of the interaction rule application:

1. In the expanded gallery 2 areas: the new exhibition 2 is displayed using various digital picture frame objects and other installation objects in the area.

Technical Implementation

Design rules that are matched and applied at stage 6:
(from the attached CD-ROM) demo\grammar\design_rule6.clp¹⁰

A general rule base that supports the GDA's reasoning at stage 6:
(from the attached CD-ROM) demo\agent\general_rule6.clp¹⁰

A digital movie that demonstrates dynamic design of the virtual gallery at stage 6:
(from the attached CD-ROM) demo\movie\stage6.avi¹⁰

Implementation of the virtual gallery design in Active Worlds:

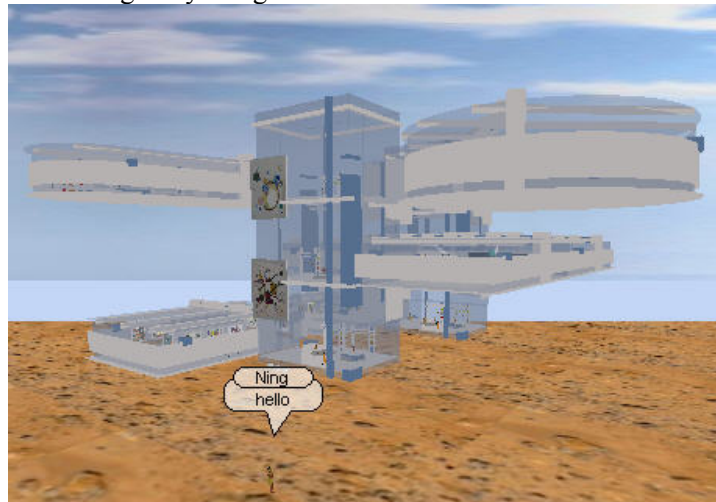

STAGE 7: SOME VISITORS LEAVE THE VIRTUAL GALLERY

Description

At stage 7 more and more visitors disconnect from the virtual world. At one point, one of the gallery 1 areas has no visitor. Acosta's GDA senses this change and applies its generative design grammar to remove this gallery area. Similar situations soon occur in one of the gallery 2 areas, and in the multi-function area.

¹⁰ “.clp” files can be opened using text editing software; for example, Notepad, WordPad and Microsoft Word. The digital movies are in standard “.avi” format and can be played using common media players. Please use speakers to hear the narrative of each movie.

Layout Rule Application

The reasoning of the GDA:

<p>Interpretations of the GDA:</p>	<p>E_{int}:</p> <ul style="list-style-type: none"> Acosta's talk ends. <p>O_{int}:</p> <ul style="list-style-type: none"> The additional reception area has no connected area. <p>wA_{int}:</p> <ul style="list-style-type: none"> The additional standard gallery 1 area has no visitor. The additional expanded gallery 2 area has no visitor. The multi-function area has no visitor. The additional reception area has no visitor.
<p>Current design goals of the GDA:</p>	<ol style="list-style-type: none"> <p>wA_{int}: The additional standard gallery 1 area has no visitor. \rightarrow Design goal $O_{exp}^F = g1-$ is hypothesised.</p> <p>wA_{int}: The additional expanded gallery 2 area has no visitor. \rightarrow Design goal $O_{exp}^F = g2-$ is hypothesised.</p> <p>E_{int}: Acosta's talk ends. wA_{int}: The multi-function area has no visitor. \rightarrow Design goal $O_{exp}^F = m-$ is hypothesised.</p> <p>O_{int}: The additional reception area has no connected area. wA_{int}: The additional reception area has no visitor. \rightarrow Design goal $O_{exp}^F = r-$ is hypothesised.</p>

The matched state labels (besides $sL=1$):

1. $sL=g1-$	Because $O_{exp}^F = g1-$ is hypothesised.
2. $sL=g2-$	Because $O_{exp}^F = g2-$ is hypothesised.
3. $sL=m-$	Because $O_{exp}^F = m-$ is hypothesised.
4. $sL=r-$	Because $O_{exp}^F = r-$ is hypothesised.

Subtractive layout rules that are matched and applied at stage 7:

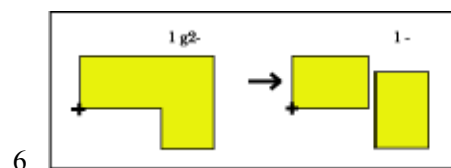
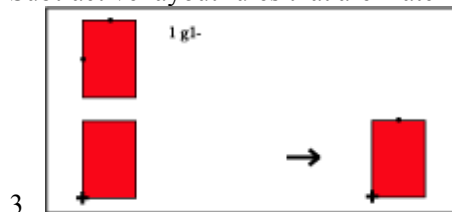

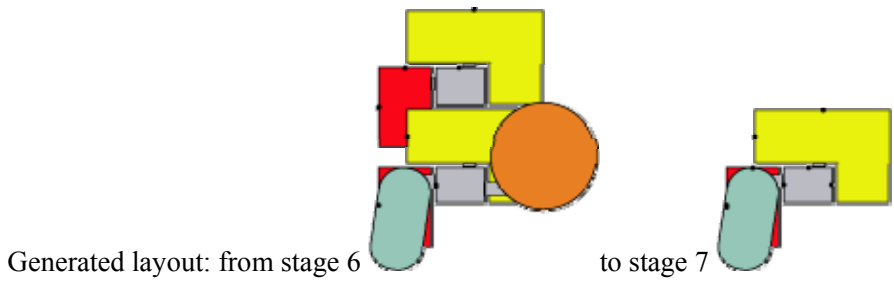
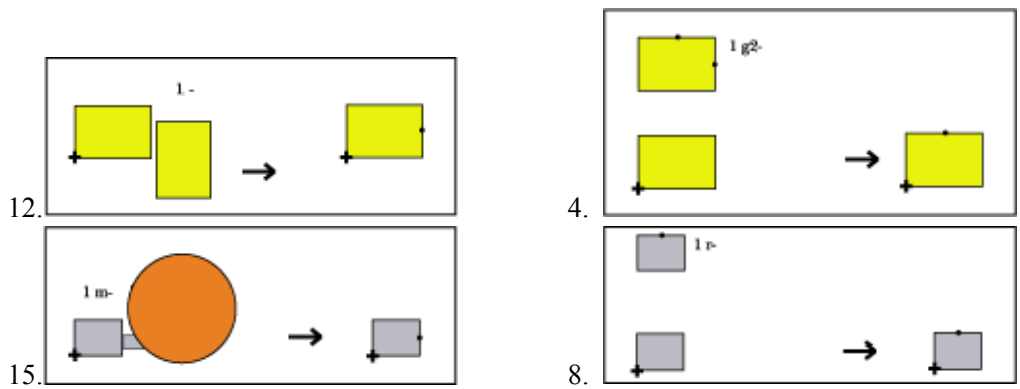

Generated layout: from stage 6 to stage 7

Object Placement Rule Application

Subtractive placement rules that are matched and applied at stage 7:

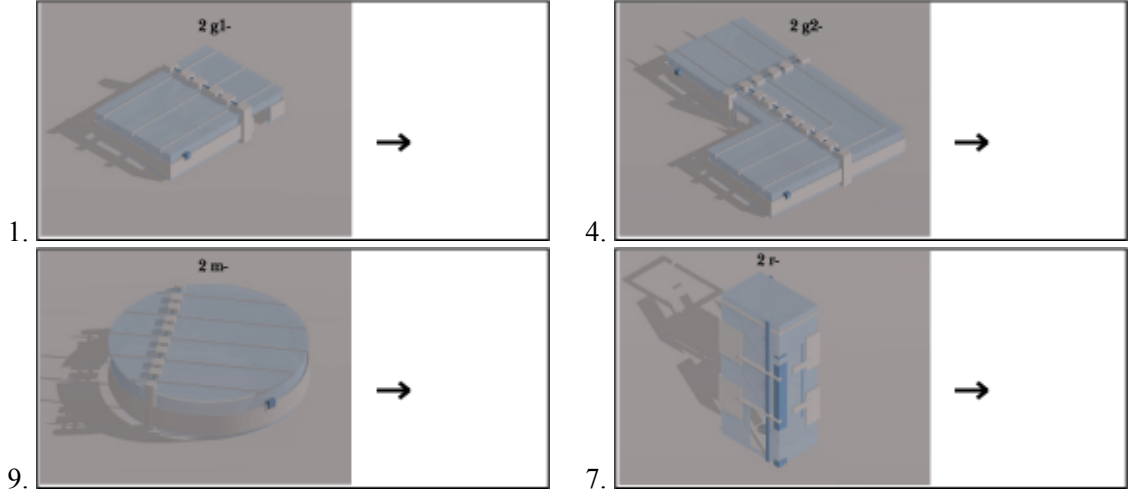

3D visualisation of the virtual gallery design for stage 7:

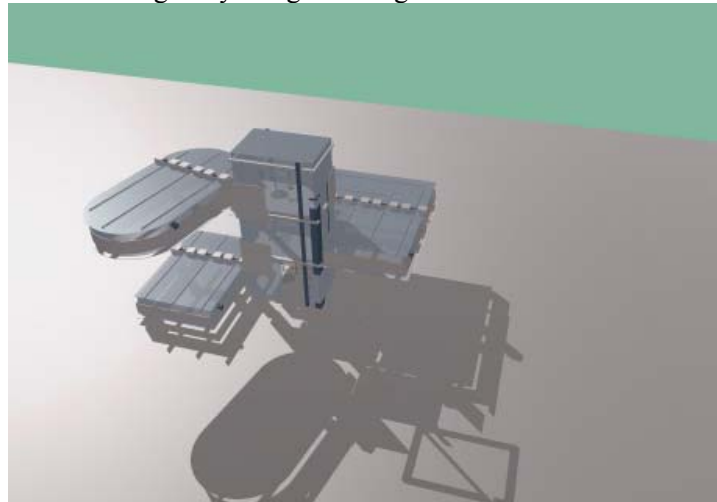

Navigation Rule Application

Subtractive navigation rules that are matched and applied at stage 7:

<p>1.</p> <p>sL=3</p> <p>IF: A pair of hyperlink portals (teleport) connects reception area a with reception area b.</p> <p> AND</p> <p> Reception area a is not sensed in the virtual gallery.</p> <p> AND/OR</p> <p> Reception area b is not sensed in the virtual gallery.</p> <p>THEN: Remove the hyperlink portals.</p>
<p>3.</p> <p>sL=3</p> <p>IF: A path is laid in a gallery area for guiding visitors in an exhibition.</p> <p> AND</p> <p> The layout of the gallery area changes.</p> <p> AND/OR</p> <p> The visual boundaries of the gallery area change.</p> <p>THEN: Remove the path.</p>
<p>5.</p> <p>sL=3</p> <p>IF: A path connects a reception area with a gallery area.</p> <p> AND</p> <p> The reception area is not sensed in the virtual gallery.</p> <p> AND/OR</p> <p> The gallery area is not sensed in the virtual gallery.</p> <p>THEN: Remove the path.</p>
<p>6.</p> <p>sL=3</p> <p>IF: A path connects a reception area with the multi-function area.</p> <p> AND</p> <p> The reception area is not sensed in the virtual gallery.</p> <p> AND/OR</p> <p> The multi-function area is not sensed in the virtual gallery.</p>

THEN: Remove the path.

Result of the navigation rule application:

- | |
|--|
| 1. The pair of hyperlink ports (teleport) that connects the 2 reception areas is demolished. |
| 2. The path that connects the additional standard gallery 1 area with its connected reception area is removed. |
| 3. The path that connects the additional expanded gallery 2 area with its connected reception area is removed. |
| 4. The path that connects the multi-function area with its connected reception area is removed. |
| 5. Paths laid in the additional standard gallery 1 area are removed. |
| 6. Paths laid in the additional expanded gallery 2 area are removed. |

Interaction Rule Application

No interaction rule is applied at stage 7. Behaviours are ascribed to virtual world objects and they are automatically extinguished if the objects are removed.

Technical Implementation

- | |
|---|
| Design rules that are matched and applied at stage 7:
(from the attached CD-ROM) demo\grammar\design_rule7.clp ¹¹ |
| A general rule base that supports the GDA's reasoning at stage 7:
(from the attached CD-ROM) demo\agent\general_rule7.clp ¹¹ |
| A digital movie that demonstrates dynamic design of the virtual gallery at stage 7:
(from the attached CD-ROM) demo\movie\stage7.avi ¹¹ |

Implementation of the virtual gallery design in Active Worlds:

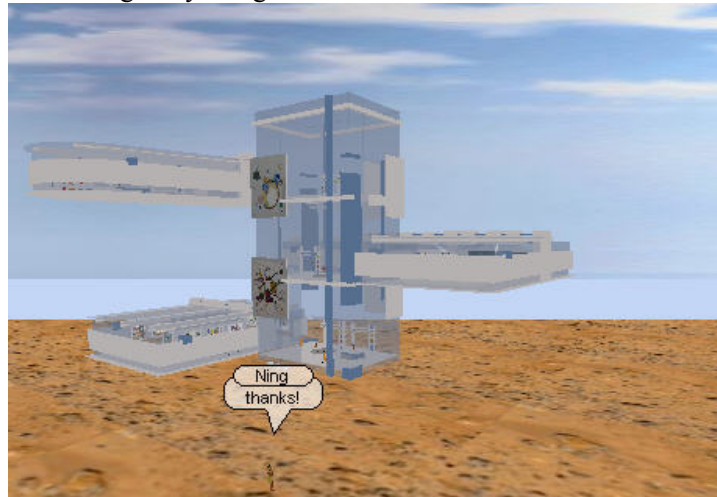

¹¹ “.clp” files can be opened using text editing software; for example, Notepad, WordPad and Microsoft Word. The digital movies are in standard “.avi” format and can be played using common media players. Please use speakers to hear the narrative of each movie.

STAGE 8: THE ARTIST LEAVES THE VIRTUAL GALLERY

Description

At the final stage of the design scenario the artist disconnects from the virtual world. The GDA records the current design of the virtual gallery for future references. The GDA then applies the example grammar to remove Acosta's personal studio area, and removes all spatial labels of the design to terminate the example grammar application before terminating its own agent program.

At the end of stage 8 a static design of the virtual gallery is generated consisting of a standard gallery 1 area, an expanded gallery 2 area and a reception area. Visitors can continue their visits of the exhibitions. The design is static as all areas of the virtual gallery will remain unchanged no matter what happens in the gallery. The dynamic design process will re-start when Acosta returns to the virtual gallery next time.

Layout Rule Application

The reasoning of the GDA:

Interpretations of the GDA:	A_{int} : <ul style="list-style-type: none"> Acosta is not present.
Current design goal of the GDA:	1. A_{int} : Acosta is not present. \rightarrow Design goal $O_{exp}^F = cS$ is hypothesised.

The matched state label (besides $sL=1$):

1. $sL=cS$	Because $O_{exp}^F = cS$ is hypothesised.
------------	---

Subtractive layout rules that are matched and applied at stage 8:

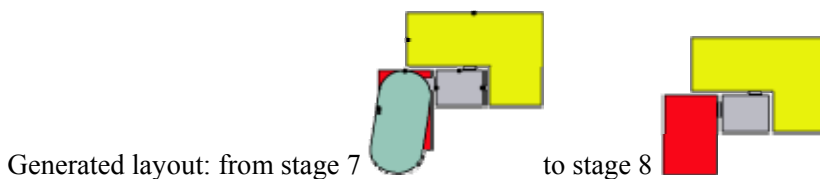
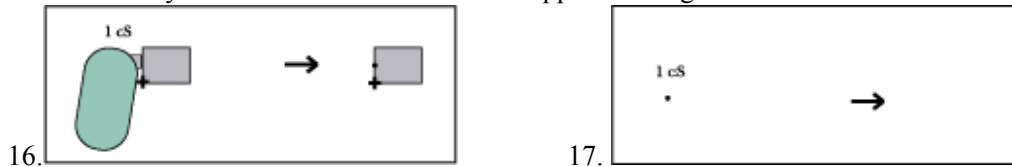

Object Placement Rule Application

The subtractive placement rule that is matched and applied at stage 8:

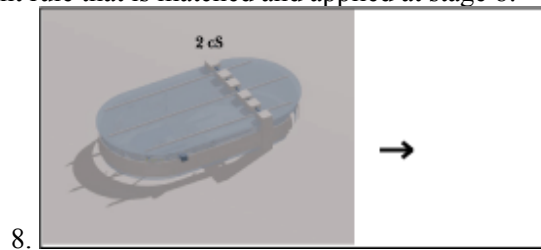

3D visualisation of the virtual gallery design for stage 8:

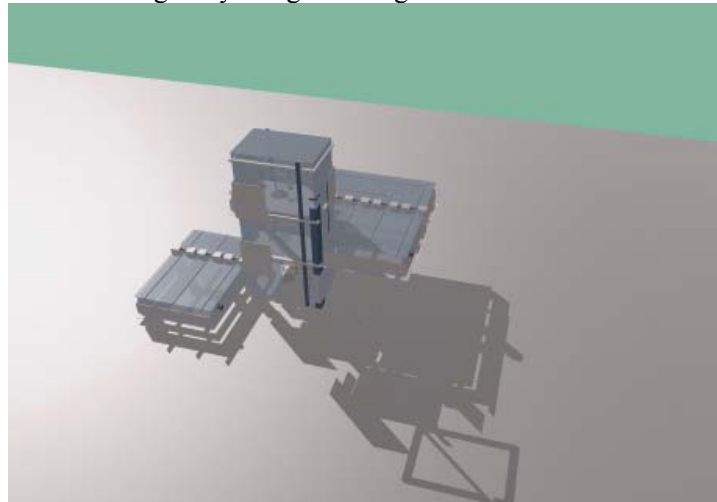

Navigation Rule Application

Subtractive navigation rules that are matched and applied at stage 8:

<p>2.</p> <p>sL=3</p> <p>IF: A pair of hyperlink portals (warp) connects floor a with floor b in a reception area.</p> <p> AND</p> <p> Floor a is not sensed in the reception area.</p> <p> AND/OR</p> <p> Floor b is not sensed in the reception area.</p> <p>THEN: Remove the hyperlink portals..</p>
<p>4.</p> <p>sL=3</p> <p>IF: A path connects a reception area with the artist's personal studio area.</p> <p> AND</p> <p> The reception area is not sensed in the virtual gallery.</p> <p> AND/OR</p> <p> The artist's personal studio area is not sensed in the virtual gallery.</p> <p>THEN: Remove the path.</p>

Result of the navigation rule application:

<p>1. In the reception area: the pair of hyperlink portals (warp) that connects floor 3 and floor 1 is removed.</p>
<p>2. In the reception area: the pair of hyperlink portals (warp) that connects floor 3 and floor 2 is removed.</p>
<p>3. The path that connects the reception area with Acosta's personal studio area is removed.</p>

Interaction Rule Application

No interaction rule is applied at stage 8. Behaviours are ascribed to virtual world objects and they are automatically extinguished if the objects are removed.

Technical Implementation

Design rules that are matched and applied at stage 8: (from the attached CD-ROM) demo\grammar\design_rule8 ¹² .clp
A general rule base that supports the GDA's reasoning at stage 8: (from the attached CD-ROM) demo\agent\general_rule8 ¹² .clp
A digital movie that demonstrates dynamic design of the virtual gallery at stage 8: (from the attached CD-ROM) demo\movie\stage8.avi ¹²

Implementation of the virtual gallery design in Active Worlds:

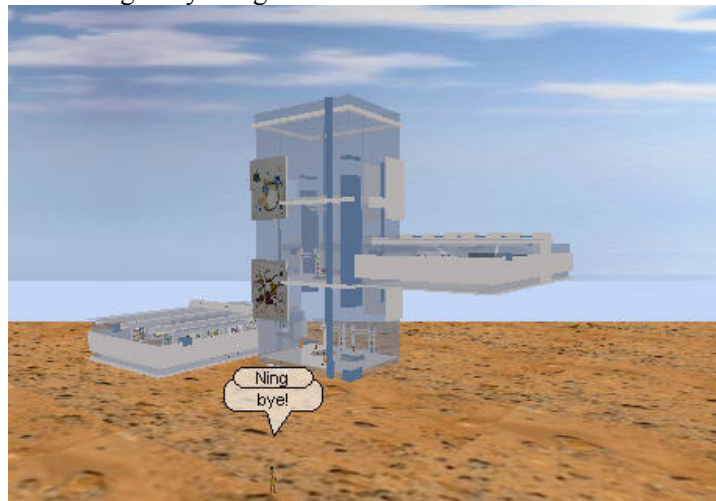

¹² “.clp” files can be opened using text editing software; for example, Notepad, WordPad and Microsoft Word. The digital movies are in standard “.avi” format and can be played using common media players. Please use speakers to hear the narrative of each movie.

DESIGN COMPARISON

Eight virtual gallery designs that are dynamically generated as needed for eight different stages of the design scenario:

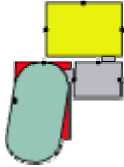
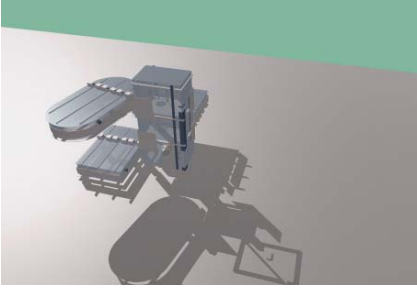
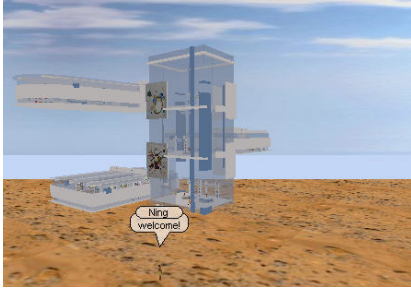
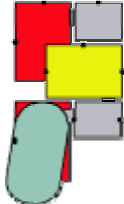
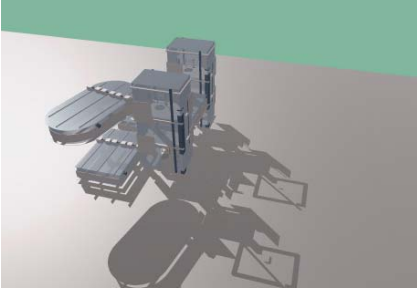
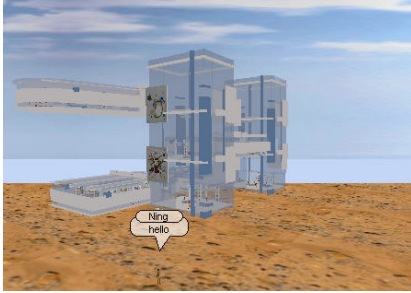
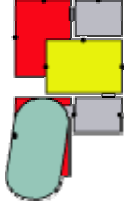
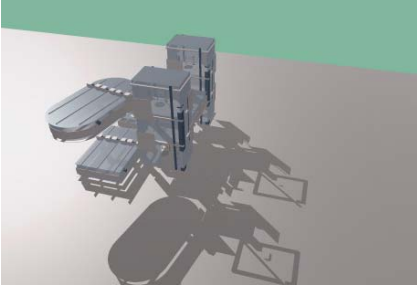
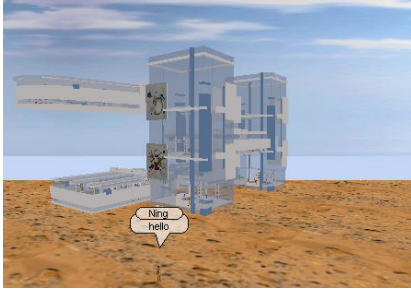
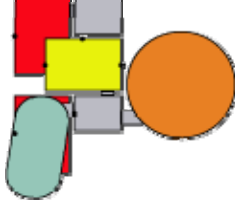
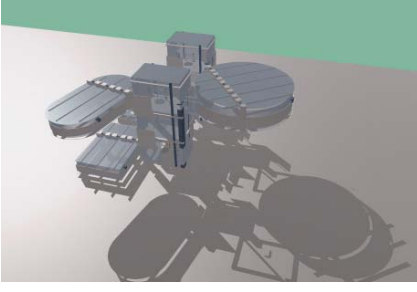
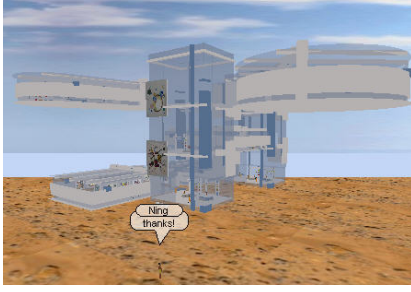
Layout	3D Visualisation	Implementation in Active Worlds
<p>Stage 1</p> 		
<p>Stage 2</p> 		
<p>Stage 3</p> 		
<p>Stage 4</p> 		

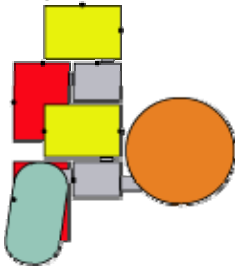
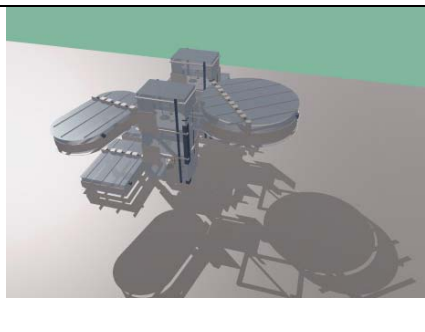
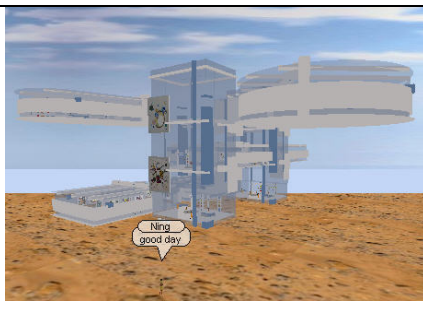
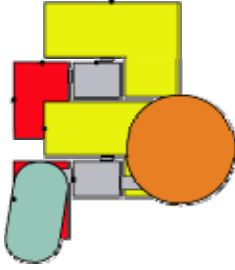
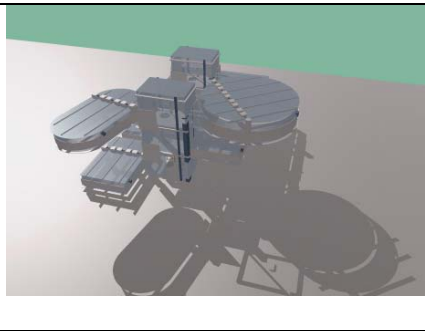
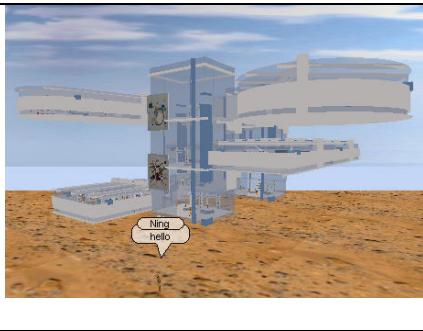
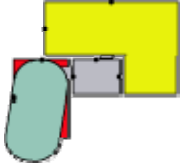
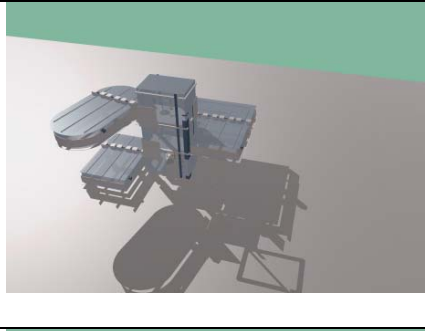
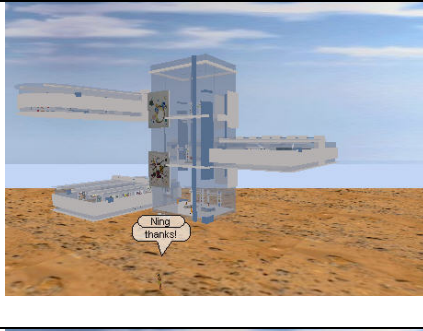
<p>Stage 5</p> 		
<p>Stage 6</p> 		
<p>Stage 7</p> 		
<p>Stage 8</p> 