Chapter 3

3D Topology Optimization with Shells

In this chapter, the design of the common milk crate is investigated with shell based topology optimization. The minimum volume design subject to both collapse and carrying loads was found. Although, milk crates hardly qualify as advanced aerospace composite structures, this study still forms a valid part of this dissertation since there are many similarities in the structural mechanics and manufacturing constraints. The method used to optimize the milk crate design could be applied to integrally stiffened composite structures with equal efficacy.

This work was presented at the Australian Environmental Engineering Research Event of 1999. Two important environmental issues are also addressed by reducing the material volume. Firstly, the amount of plastic entering the environment per item can be reduced. Secondly, the weight and hence the energy of transporting the product are minimised. Thus, in addition to addressing some important aspects of thin panel structures, this work also demonstrated how use of technology from the aerospace industry could allow engineers to place greater emphasis on environmental issues.

3.1 Introduction

3.1.1 Reasons to Minimise Material Usage

The life cycle of a plastic milk crate is quite similar to many injection moulded plastic products. This life cycle makes use of many natural resources. The most obvious resource is the petroleum oil used to create the plastic. Plastic, like all secondary products, impacts the environment through energy used in transportation of raw products, energy of processing and the omission of by-products due to

processing. The magnitude of these environmental impacts is proportional to the volume of plastic in the design.

Another class of environmental impact relates to the transportation of the product. Each time the crate is used to transport milk, the vehicle used to carry it undergoes numerous accelerations and decelerations. The weight of the crate will make a small but cumulative contribution to the energy required for these accelerations. The life span of a typical crate can be assumed to be of the order of a decade taking into account losses, and damages. Over this period the crate will be responsible for a significant amount of energy expenditure. This energy will come at a cost to the environment, regardless of mode of transport. The end of the milk crate's life will effect the environment also. If the crate is recycled, there will be an associated energy cost. In the case of disposal, the environment will be littered with a volume of plastic equal to that of the crate. From an economic point of view, companies who design such products should note that by minimising the volume, material costs are also reduced in a proportional manner.

3.1.2 Evolutionary Structural Optimisation

The method of Evolutionary Structural Optimisation (ESO) by Querin *et al.* (1997) was used to optimize the milk crate design. ESO is a simple and practical topology optimization method whereby small volumes of material are removed from a finite element model. ESO makes repeated use of the STRAND6 (G+D Computing) program to perform FEA. Optimization is performed with a heuristic algorithm that removes or modifies the material properties of the finite elements that contribute least to the strength of the structure. The removal of finite elements from the model must be a gradual process since the behaviour of the structure can change significantly during the optimisation and it is controlled by the stresses in each of the elements.

In each iteration ESO removes a small fraction of the elements with the lowest Von Misses stress. The elements to be removed satisfy the following inequality:

$$\sigma_{VM,e} \leq RR \times \sigma_{VM,max} \quad (3.1)$$

where $\sigma_{VM,e}$ is the Von Mises stress of element e , $\sigma_{VM,max}$ is the maximum Von Mises stress occurring in the structure at that iteration and RR is the Rejection Ratio that controls the element removal process and is controlled by,

$$RR = a_0 + a_1 \times SS + a_2 \times SS^2 + a_3 \times SS^3 + \dots \quad (3.2)$$

where SS is an integer called the Steady State number that is incremented each time the application of (3.1) results in no element removals.

The choice of when to cease removing elements is arbitrary so the designer must apply some criteria to evaluate the optimality of the evolving design. Querin *et al.* (1998) developed a function known as the Performance Index (PI) that is a good indicator of the level of stress sharing in the design. When the PI is lowest, the structure is most evenly stressed and this means that any stress concentrations are minimised. Since failure usually occurs at the region of highest stress, taking the design with the lowest PI results in the topology with the best strength to weight ratio. Since multiple load case ESO was applied in this work, the PI was calculated as per Querin (1997):

$$PI_{ML} = \frac{\sum_{l=1}^{LC} \left\{ \frac{\sum_{e=1}^N \sigma_e V_e}{F_l L} \right\}^l}{LC} \quad (3.3)$$

where LC is the number of load cases, N is the number of finite elements in the model and F_l is the resultant applied load for the l th load case

3.1.3 The Milk Crate Design Problem

For the purpose of this paper, two design loads were assumed. Firstly, the crate must be able to carry 16 one litre containers of milk. Since there are four handles on the crate, it was assumed in this paper that either pair of two opposite handles must carry this load. The other assumed loading corresponds to 5 full milk crates being stacked on top. In this case, the mechanism of failure is assumed to be buckling. The internal dimensions for the crate are fixed by the geometry of the milk containers and here, the interior was chosen to be a cubic region with side length 500mm.

The exterior dimensions are somewhat arbitrary but the choice was a cube with side length 550mm. Hence, all the material of the crate must lie within a 25mm thick envelope of space. See Figure 3.1 for a description of the design envelope.

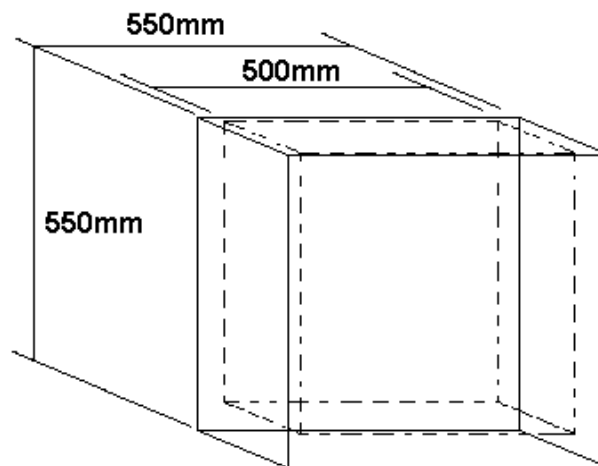

Figure 3.1, Diagram showing design envelope for the milk crate

3.2 Optimization Approach

3.2.1 The Initial Design Model

On examination of contemporary milk crate designs, one will notice two distinct types of structure. Firstly, there is ‘web’ structure over some regions on the interior surface of the design envelope. Secondly, there are multiple ‘stiffeners’ extending out to the exterior of the design envelope. Figure 3.2 demonstrates these two types of structure.

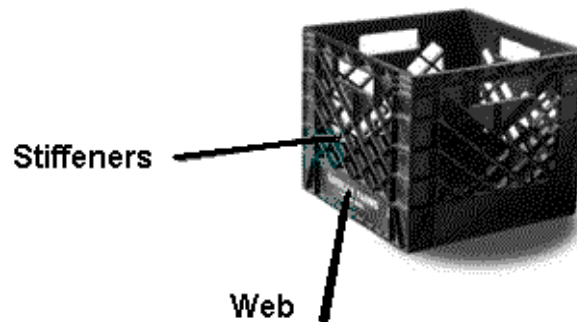

Figure 3.2, Diagram indicating web and stiffener regions

In keeping with existing designs and their manufacturing methods, it was decided that the optimisation goal would be to find the arrangement of webs and stiffeners with the lowest volume. Figure 3.3 shows the initial FEA model containing a full design space, i.e. all possible locations for webs and stiffeners are used. The stiffeners run only horizontally and vertically for modeling simplicity. Each little web or stiffener is represented by one finite element.

3.2.2 Loads and Boundary Conditions for the Finite Element Modeling

Since the crate is symmetric about two axes, the analysis was carried out with a one-quarter symmetry model. The planes of symmetry contain the XZ and YZ axes vectors respectively.

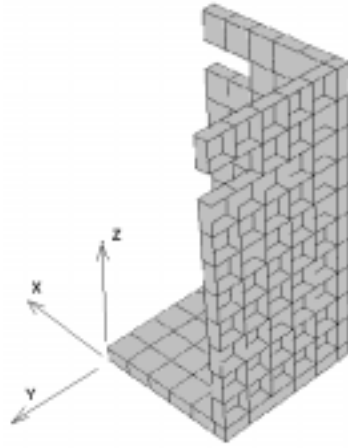

Figure 3.3, The initial FEA model (using one-quarter symmetry)

The two types of loading discussed above require three separate analyses, one for the collapse loading and two for each of the pairs of handles used for carrying. The multiple load cases option of ESO was applied to optimize under these separate analyses. A linear buckling analysis was performed using STRAND6 to determine the mode shape for the collapse of the milk crate when subjected to the load of 5 crates above it. Figure 3.4 shows the mode of collapse and it involves two opposite faces bending inwards and the two other opposite faces bending outwards.

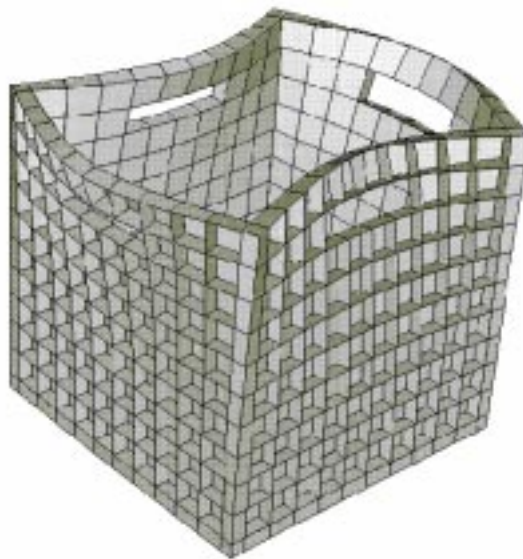

Figure 3.4, Collapse mode for the crate with others stacked above
(doubly symmetric model shown)

To capture this type of failure, the collapse loading was modeled by a set of forces causing deformations in the structure similar to the buckling mode shape (see left of Figure 3.5). For the case where the crate was carried by its handles, the loads on the structure are as shown in the centre and right of Figure 3.5.

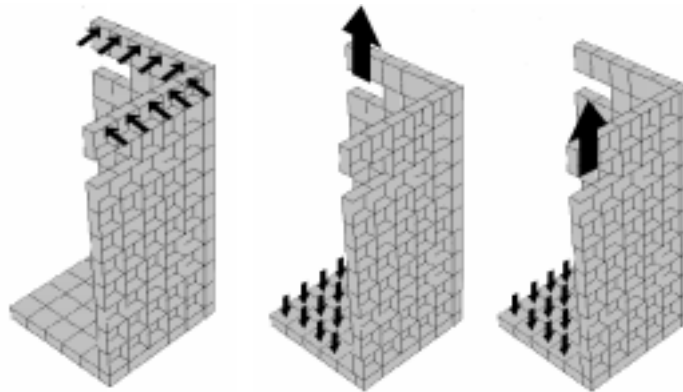

Figure 3.5, Load cases chosen to capture the collapse and handle carrying loads

The ratio of the collapse load to the carry loads is somewhat arbitrary. The choice of this ratio will influence the relative performance of the design under the different conditions. The ratio used in this example was 9:4 to bias the design towards the collapse load, which is larger than the carrying load.

3.3 Results

3.3.1 The Theoretical Optimal Design

Figure 3.6 shows the design when the minimum PI was reached according to (3.3). The strength of the design was not directly considered during this topology optimisation. Rather, the optimisation was used to provide guidance regarding the best shape or topology. The optimal topology had a 12% reduction of volume over the initial design of Figure 3.3.

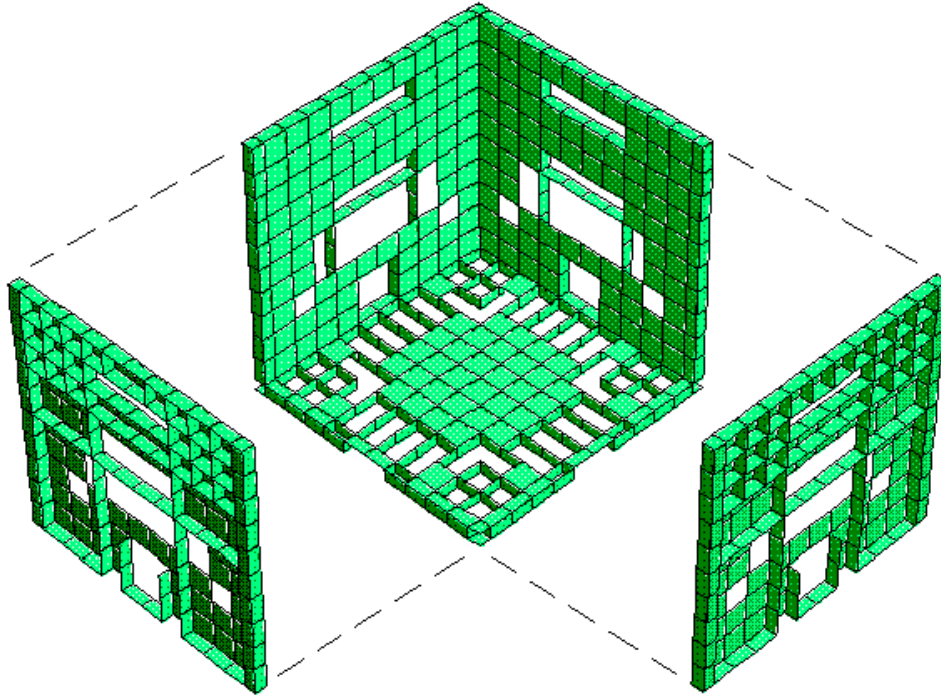

Figure 3.6, Exploded image of the theoretical optimum design

3.3.2 Interpreting the Result into a Real Design

Arguably the most difficult part of structural topology optimisation is interpreting the results. When doing this, there is a need to reflect on what design features are indicated. The final FEA model in Figure 3.6 could not be directly converted into a new design since the results were influenced by the formulation of the optimization problem. A number of issues regarding the formulation are discussed in this section.

Firstly, all of the stiffeners included in the initial model were either horizontal or vertical. There is no such restriction on a real design and hence, it is important to look for regions where angled members are desirable. In Figure 3.6 a pair of stiffeners runs vertically from top to bottom on each of the side faces. A second pair of vertical stiffeners remains only near the bottom of the side faces. It would be possible to remove the smaller stiffeners and compensate by thickening the longer stiffeners

towards the bottom. Also, these longer stiffeners could be modified to curve into an angle near the base, intersecting the base at a location between the existing intersections. A similar approach could be applied to stiffeners in the base itself, which appears to favour a radial pattern from its center.

Another issue related to the optimisation formulation is the choice of the thicknesses for the web and stiffener regions. In this work, a nominal thickness of 2mm was chosen for both types of structure. This may have influenced the results since the use of thicker stiffeners might have reduced the need for the web regions and vice-versa. Hence, choosing a different initial model could alter the proportion of webs in the optimised structure.

Through due consideration of the above-mentioned issues, it is clear that the conversion from a theoretically optimal design to a real-world design is possible with only a few minor changes. Also, any engineer with FEA experience would be able to apply such a method with little instruction. This makes ESO a viable option during preliminary design of injection moulded plastic products such as milk crates. The analysis of real designs requires more accuracy than preliminary designs. Hence, issues such as mould flow effects and off-design loads should be considered after preliminary design details have been chosen.

3.3.3 Comparison with Existing Design

Figure 3.7 shows a finite element model of an existing design that was created and for comparison with the ESO optimized design presented above.

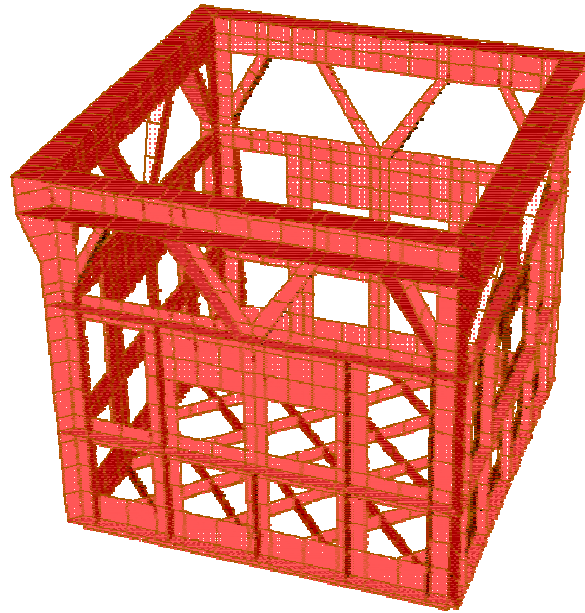

Figure 3.7, A finite element model of an existing milk crate design

To form a meaningful comparison between the two designs, the shell thicknesses of the ESO design were manually adjusted until the buckling load equaled that of the existing design. Then the peak stresses in the handle regions were evaluated with linear static finite element analysis. Table 3.1 shows these values along with a number of other properties of the two designs.

Design	ESO aided design	Existing design
Weight	0.91 kg	1.05 kg
Buckling Load	2.67 kN	2.67 kN
Peak Handle Stress (Von Mises)	3.1 MPa	3.8 MPa
Load Transfer	Load shared between skin and stiffeners	Truss-like stiffeners carry most load
Stiffener Type	Orthogonal stiffeners	Angled members

Table 3.1, Comparison of ESO design with existing design

Table 3.1 shows that the buckling loads of the two milk-crate designs were indeed equal. At this buckling load, the ESO design is more efficient since it weighs only 0.91kg whereas the existing design weighs 1.05kg (both models assumed the same material stiffness and density). This 13% saving in weight is probably due to more efficient distribution of loads in the ESO design. Furthermore, the ESO design also had lower peak stresses near the handles – a further sign of a more optimal topology.

The basic method of load transfer in the two designs is also compared in Table 3.1. This difference goes some way to explaining the relative success of the ESO design. The load transfer in the existing design is through truss-like stiffeners whereas the ESO design shares the load between the skin and stiffeners (like a typical aircraft design). The final row of Table 3.1 mentions the stiffener types of the two designs. The use of only orthogonal stiffeners in the ESO design suggests that an even more optimal design could be achieved if angled members were also possible. However, this option was not considered in this investigation due to limitations on computational resources.

3.4 Conclusion

An optimal topology for a milk crate design can be found with ESO. The optimal topology had significantly less volume than the existing design that was modeled due to better sharing of the stresses in the structure. This paper has shown that both web and stiffener type structures are useful in different regions of the milk crate. The conversion of such topologies into real designs is possible with relatively few modifications. Hence, designers seeking to minimise the volume of plastic in injection moulded products now have access to effective design optimization through ESO. This option is desirable for design engineers since it allows them to minimise the environmental impact of their products.

The approach used in this design task could be readily applied to any thin panel structure involving integral stiffening. However, the manufacturing of such structures made from composite materials would be of high complexity due to the incomplete grids and cutouts in the base panels. Adequate mold flow in the stiffener regions could also be an important limiting factor, both for injection moulded and fiber reinforced polymers.

References

G+D Computing, *STRAND6 Reference Manual and User Guide*, G+D Computing, Sydney, Australia, 1993.

Querin, O. M., 'Evolutionary Structural Optimization: Stress Based Formulation and Implementation', *Ph.D. dissertation, Dept. of Aeronautical Engineering, The University of Sydney*, Australia, 1997.

Querin O.M., Steven G.P., *EVOLVE User Guide*, Department of Aeronautical Engineering, University of Sydney, 1997.

Querin O.M., Steven G.P. and Xie Y.M., "A Performance Indicator for Structural Topology Optimization", *Journal of Structural Optimization*, (accepted for publication), 1998.

Xie Y.M., Steven G.P., "A simple evolutionary procedure for structural optimisation", *Computers and Structures*, **49**, 885-8963, 1993.

Xie Y. M., Steven G.P., *Evolutionary Structural Optimisation*, Springer, Berlin, 1997.

Zienkiewicz O.C., *The Finite Element Method, Third Edition*, McGraw Hill, London, 1977.