

TENSILE AND BEND PROPERTIES OF .016 INCH  
DIAMETER ORTHODONTIC WIRES

Clive Leslie Cox B.D.S. University of Sydney

*A Thesis submitted in partial  
requirement for the degree of  
MASTER OF DENTAL SURGERY*

Department of Preventive Dentistry  
Faculty of Dentistry  
University of Sydney

1973

## ACKNOWLEDGEMENTS

*This research work was carried out at the Dental School, University of Sydney, New South Wales, Australia.*

*I wish to thank Mr. K. Godfrey, Senior Lecturer in Preventive Dentistry, my supervisor, for his help, advice and guidance during this research project.*

*I am indebted to Dr. Earnshaw, Reader in Prosthetic Dentistry, for his invaluable guidance in experimental work, and general assistance.*

*Dr. P.J. Brockhurst was of great assistance throughout this undertaking, and I am grateful for this help.*

*My thanks to Mr. P. Ward for the preparation of the photographic material, and Miss B. Bischoff for the tracing of the graphs.*

*Finally, I wish to pay tribute to my wife Betty for her encouragement throughout.*

Faculty of Dentistry  
University of Sydney,  
New South Wales,  
Australia.

## INDEX

|                   |   | Page      |
|-------------------|---|-----------|
| <b>Chapter 1.</b> | <b>History of Archwires</b>                       | <b>1</b>  |
| 1.1.              | Heavy Wires                                       |           |
| 1.2.              | Light Wires                                       |           |
| <b>Chapter 2.</b> | <b>The Begg Light Wire Technique</b>              | <b>4</b>  |
| 2.1.              | Stage I   |           |
| 2.1.1.            | Stage II  |           |
| 2.1.2.            | Stage III   |           |
| 2.2.              | Forces Involved with .016 inch Archwire           |           |
| 2.3.              | The Problem                                       |           |
| 2.4.              | The Archwire                                      |           |
| <b>Chapter 3.</b> | <b>Archwire Materials</b>                         | <b>11</b> |
| 3.1               | Precious Metals                                   |           |
| 3.1.1.            | Silver  |           |
| 3.1.2             | Tungsten  |           |
| 3.3.3.            | Stainless Steel                                   |           |
| 3.2.              | Light Wire Techniques                             |           |
| 3.3.              | Testing of Wires                                  |           |
| <b>Chapter 4.</b> | <b>Elasticity and Strength of Materials</b>       | <b>15</b> |
| 4.1.              | Stress, Strain and Elasticity                     |           |
| 4.1.1.            | Elastic Material                                  |           |
| 4.1.2.            | Tensile Stress and Strain                         |           |
| 4.1.3.            | Compressive Stress and Strain                     |           |
| 4.1.4.            | Shear Stress and Strain                           |           |
| 4.1.5.            | The Stress-Strain Relationship                    |           |
| 4.1.6.            | Elastic Limit                                     |           |
| 4.1.7.            | Yield Point                                       |           |
| 4.1.8.            | Yield Stress                                      |           |
| 4.1.9.            | Proof Stress                                      |           |
| 4.1.10            | Ultimate Tensile Strength                         |           |
| 4.1.11            | Ductility   |           |
| 4.1.12.           | Toughness   |           |
| 4.1.13.           | Beams   |           |
| 4.1.14.           | Strain Energy: Resilience                         |           |
| 4.2.              | Bending Moments and Shearing Forces               |           |
| 4.3.              | Stresses Due to Bending                           |           |
| 4.3.1.            | The Stresses on a Cross Section Uniplanar Bending |           |
| 4.3.2.            | Position of Neutral Axis                          |           |
| 4.3.3.            | The Moment of Resistance                          |           |
| 4.3.4.            | The Moment of Inertia                             |           |
| 4.3.5.            | Calculation of Bending Stresses in a Beam         |           |
| 4.3.6.            | Bending Moment of a Cantilever                    |           |
| 4.4.              | Deflection of Beams                               |           |
| 4.4.1.            | Deflection of Cantilever Beam                     |           |

|                   |   |           |
|-------------------|---|-----------|
| <b>Chapter 5.</b> | <b>Types of Tests</b>                         | <b>44</b> |
| 5.1.              | Previous Work                                 |           |
| 5.1.1.            | Tensile Tests                                 |           |
| 5.1.2.            | Bend Tests                                    |           |
| 5.2.              | Elastic Strength of Structure                 |           |
| 5.4.              | Load Deflection Rate                          |           |
| 5.5.              | Differential Force                            |           |
| 5.6.              | Optimal Force                                 |           |
| <br>              |   |           |
| <b>Chapter 6.</b> | <b>Materials</b>                              | <b>53</b> |
| 6.1.              | Stainless Steel                               |           |
| 6.1.1.            | Discovery                                     |           |
| 6.1.2.            | 18.8 Stainless Steel Wire                     |           |
| 6.1.3.            | Production of Stainless Steel Wire            |           |
| 6.1.4.            | Heat Treatment                                |           |
| 6.1.5.            | 18.8 Experimental Wire                        |           |
| 6.1.6.            | Precipitation Hardenable Stainless Steel Wire |           |
| 6.1.7.            | Experimental Wire                             |           |
| 6.2.              | Cobalt Chromium                               |           |
| 6.2.1.            | Heat Treatment                                |           |
| 6.3.              | Cobalt Chromium Experimental Wire             |           |
| <br>              |   |           |
| <b>Chapter 7.</b> | <b>Tensile Testing</b>                        | <b>66</b> |
| 7.1.              | Method  |           |
| 7.1.1.            | Diameter of Wire                              |           |
| 7.2.              | Resistance to Failure on Bending              |           |
| 7.2.1.            | Method  |           |
| 7.3.              | Bend Testing                                  |           |
| 7.3.1.            | Apparatus                                     |           |
| 7.3.2.            | Test Procedure                                |           |
| <br>              |   |           |
| <b>Chapter 8.</b> | <b>Results</b>                                | <b>78</b> |
| 8.1.              | Resistance to Failure on Bending              |           |
| 8.2.              | Diameter of Wires                             |           |
| 8.3.              | Tensile Tests                                 |           |
| 8.3.1.            | Proof Load                                    |           |
| 8.3.2.            | Ultimate Tensile Strength                     |           |
| 8.3.3.            | Proof Stress and Modulus of Elasticity        |           |
| 8.3.4.            | Typical Load Strain Curves                    |           |
| 8.4.              | Bend Tests                                    |           |
| 8.4.1.            | Proof Load                                    |           |
| 8.4.2.            | Load Deflection Rate                          |           |
| 8.4.3.            | Proof Stress and Modulus of Elasticity        |           |
| 8.4.4.            | Permanent Set                                 |           |
| 8.4.5.            | Load Deflection Curves                        |           |

|                     |   |            |
|---------------------|---|------------|
| <b>Chapter 9.</b>   | <b>Clinical Significance of Results</b> | <b>97</b>  |
| 9.1.                | Ductility                               |            |
| 9.2.                | Elastic Strength                        |            |
| 9.3.                | Load Deflection Rate (Stiffness)        |            |
| 9.4.                | Permanent Set with the same Loading     |            |
| 9.5.                | Comment                                 |            |
| 9.5.1.              | The Best Wire for the Technique         |            |
| 9.5.2.              | Standardisation of Wires                |            |
| 9.5.3.              | Ultimate Tensile Strength               |            |
| 9.5.4.              | Proof Stress and Modulus of Elasticity  |            |
| 9.5.5.              | Indications for Future Work             |            |
| <b>Chapter 10.</b>  | <b>Summary</b>                          | <b>101</b> |
| <b>Bibliography</b> |   | <b>103</b> |

## LIST OF ILLUSTRATIONS

- Figure 2.1. A. Upper and Lower Archwires with vertical loops, before being applied to the teeth.  
B. Similar Looped Archwire shown in position on the teeth.
- 2.2. Light round archwire placed on the teeth.
- 2.3. Anchorage bend bitten out by patient. The operator must restore this bend to avoid treatment failure.
- Figure 4.1. Forces on a Longitudinal Bar.
- 4.2. Shear Forces on a Rigid Bar.
- 4.3. Wire in Tension.
- 4.4. Typical Stress Strain Curve.
- 4.5. Stress Strain Curve Plastic Deformation.
- 4.6. Stress Strain Curve. Proof Stress.
- 4.7. Beams — Bending
- 4.8. Work done in Stretching a Bar.
- 4.9. Bending Moment of a Cantilever Beam
- 4.10. Effect of a load on a Cantilever Beam.
- 4.11. Effect of more than one load on a Cantilever Beam
- 4.12. Positive and Negative Bending and Shearing.
- 4.13. Stress on a cross-section; Uniplanar Bending.
- 4.14. Variation in Stress due to Bending.
- 4.15. Deflection of Beams — Curvature.
- 4.16. Bending Moment and Shearing Force Diagrams of a Cantilever Spring.
- 4.17. Deflection of a Cantilever Spring.
- Figure 7.1. Hounsfield Tensometer Type W.
- 7.2. Vee-Wire Grips.
- 7.3. Close up of Vee-Wire Grips and Huggenberger Extensometers.
- 7.4. Disc Wire Chucks
- 7.5. Ductility Testing Apparatus (Cold Bend Test).
- 7.6. Tinius Olsen 6 inch Pound Cap.  
Stiffness Testing Machine and Specifications.
- 7.7. Tinius Olsen 6 inch Pound Cap.  
Stiffness Testing Machine — Description.

## Chapter 1

### 1. HISTORY OF ARCHWIRES

#### 1.1. Heavy Wires

From earliest time, orthodontic work was undertaken to improve appearance and function.

Man observed displeasing dental abnormalities, conceived a plan to overcome the condition, and then searched for suitable materials to carry out the treatment.

Metals were the most suitable materials available. Native gold, copper and meteoric iron had been in use since 4000 B.C. (Metals Handbook 1961)(51). These in the unalloyed form, were worked to fashion weapons, ornaments and tools. Because of their strength and lack of bulk, it is little wonder that they were first choice for dental appliances.

Metals were used for splinting, and also to replace lost teeth. In 2300 B.C. anterior teeth were splinted, by winding gold wire round the gingival margins (Weinberger 1948)(78). 700 B.C. the Etruscans (Weinberger 1948)(79) used riveted and soldered gold bands, to maintain natural and artificial teeth in place.

However it was not until 1723 that metal was used to form an archwire, corresponding to our present concept of an archwire. This method of treatment introduced by Pierre Fauchard (Anderson 1948)(1) consisted of a metal "Band" or "Bandalette" fashioned of gold or silver, and attached to the buccal of the teeth, or the lingual, according to whether the tooth was displaced to the buccal or lingual. Perforations were made in the bar. Silk ligatures were threaded through the bar and around the teeth. The ligatures were tightened from time to time, to align the teeth.

The arch bar and attachments have undergone many improvements since that time.

Joseph Fox (1803) (Anderson 1948) (2) of England extended the archwire to the molars and at the same time attached ivory bite opening blocks to the molars. He maintained that all obstructions must be removed before tooth movement can take place.

The mechanical efficiency of these archwires was improved by swaged gold bands on the molars for anchorage (Harris 1839) (3), bands clamped to the teeth by means of screws (Schange 1841) (4), buccal tubes on the molar bands to take the archwires (Evans 1854) (5) and the cementing of platinum bands on the teeth (Magill 1871) (6).

Orthodontic knowledge had increased tremendously since the time of Fauchard, but, it was E. H. Angle 1855-1930 (7) who did perhaps more than anyone else to systematise and organise this knowledge. He introduced a classification of malocclusion that has survived to the present day. Also he introduced some of the most efficient appliances to that time. They included the E arch 1909, the pin and tube appliance 1912, the ribbon arch 1916, and finally the edgewise appliance in 1916. The edgewise appliance consisted of a heavy rectangular gold-platinum archwire, which was fitted into rigid rectangular brackets on bands cemented onto the teeth. In all these appliances the underlying principle was a semi-resilient archwire, fashioned to an ideal archform, and the teeth moved by relatively heavy forces.

## 1.2. Light Wires

Dr. Angle was a very prominent figure, and consequently there were many followers of his theories and techniques. There were other men who disagreed with the principle of heavy forces to move teeth, and advocated the use of light force by means of light wire. Techniques have varied according to whether relatively light or heavy forces are used.

In 1918 Robinson (60) introduced light wires of .018 inch tungsten and .020 inch platinum gold wire, which after forming into the required arch shape,

was sufficiently flexible to be attached to the teeth, and sufficiently resilient to return to their former arch shape. The teeth were thus moved as required with less force and much less pain.

In the following years and up to the present time, many techniques and appliances have been introduced, using a combination of light and heavy wires or light wires only. A Combination of light and heavy archwires were used by Charles Tweed 1941 (75). His technique used light round wire (.016", .018" or .020") initially to align the teeth and finishing up with rectangular (.025" x .028") wire for torquing purposes.

Similarly, the Atkinson Universal Appliance (1937) (9) was able to use light and heavy wires.

An appliance using Twin Light wires (.010") was introduced by Johnson 1938 (47). With this either one or two light wires could be used.

Jarabak (46) introduced a technique in 1963 using .016" round wire, and Begg 1954 (13) a technique using .018" round heat treated wire, which was subsequently changed to a .016" wire. The Jarabak Technique in the initial stages required a complex helical loop system, which was very demanding of wire performance. The Begg Technique and Theory involve our present problem and will be discussed in greater detail.

## Chapter 2

### 2. THE BEGG LIGHT WIRE TECHNIQUE

---

This technique is divided into three stages, and each stage needs to be completed, before the next stage is commenced.

#### 2.1. Stage I

This stage requires the use of .016 inch diameter stainless steel wire. Dr. Begg (Begg 1965)(14) states that Wilcock wire, because of resiliency, toughness, and tensile strength is the most suitable for the technique.

The following objectives are reached.

- (a) The bite is opened
- (b) The anterior teeth are aligned. With the case of Class I and Class II malocclusions these incisor teeth are adjusted to edge to edge relationship or over moved according to the treatment plan.
- (c) Crowded teeth are aligned. This may require the inclusion of loops in the archwire (Figure 2.1.)
- (d) Spaces between teeth are closed. This may also require the inclusion of loops in the archwire.
- (e) Rotations are corrected.
- (f) Unerupted teeth are brought into occlusion.
- (g) Molar relationships are corrected.
- (h) Cross bites are corrected.

Intermaxillary elastics are worn, and bite opening and anchor bends are incorporated in the archwire.

#### 2.1.1. Stage II

.016 inch diameter wire is again used.

In this stage any extraction spaces are closed by the use of intramaxillary elastics.

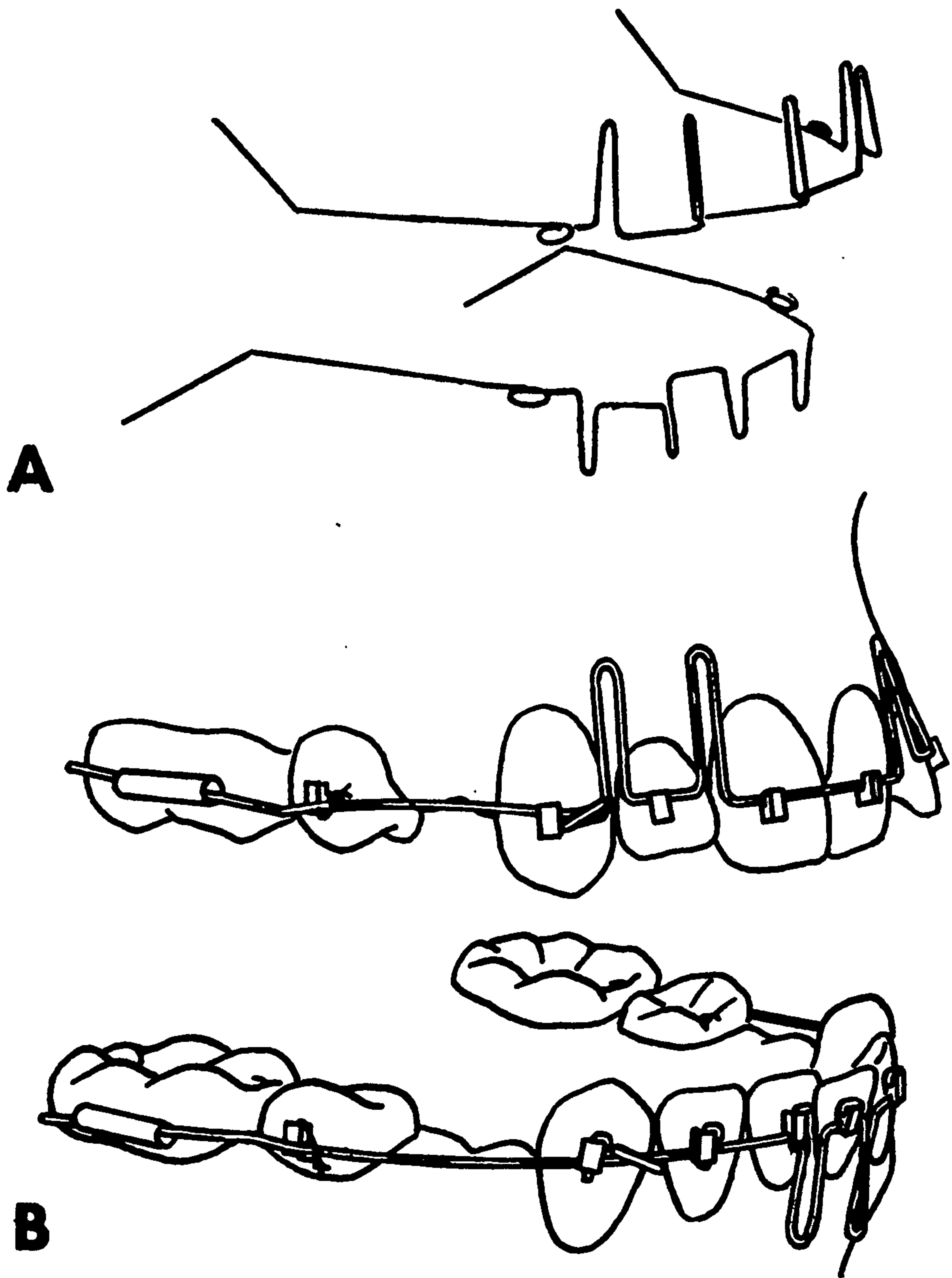

Fig. 2.1

- A. Upper and lower arch wires with vertical loops before being applied to the teeth.
- B. Similar looped arch wires shown in position on the teeth.

(P.R. Begg 1965.) (15)

Anchor and bite opening bends are again incorporated in the archwire, and intermaxillary elastics are worn as required.

### 2.1.2. Stage III

There is a change to heavier wire in this stage. .020 inch diameter is used for the upper and .018 inch diameter for the lower wire.

In addition uprighting springs, and a torquing arch are used to correct axial inclinations of the teeth.

Intermaxillary elastics are worn as required.

### 2.2. Forces involved with .016 inch archwire

(1) The archwire is contoured to the required arch form, and pinned to the brackets on the teeth. This provides the force necessary to align the teeth.

(2) Included in the archwire are the anchor and the bite opening bends. They are incorporated in the archwire just mesial to the molar buccal tubes. They are of sufficient angle to permit the labial portion of the archwire to rest lightly against the labial sulcus when the wire is in an unstrained position in the buccal tubes.

When pinned into the brackets on the teeth (Figure 2.2.) forces are created (a) sufficient to depress the anterior teeth (b) retain the anchor molars in a relatively unchanged position, against the tilting effect of the intermaxillary elastics.

This Differential-Type Force (Smith and Storey 1952) (70) (71) is used extensively in the technique (see also (5.6)).

The elastic force in Stage I is used to tip the anterior teeth posteriorly. In Stage II it is used to maintain an edge-to-edge relationship of the anterior teeth (intermaxillary elastics), and to close any extraction spaces (intramaxillary elastics).

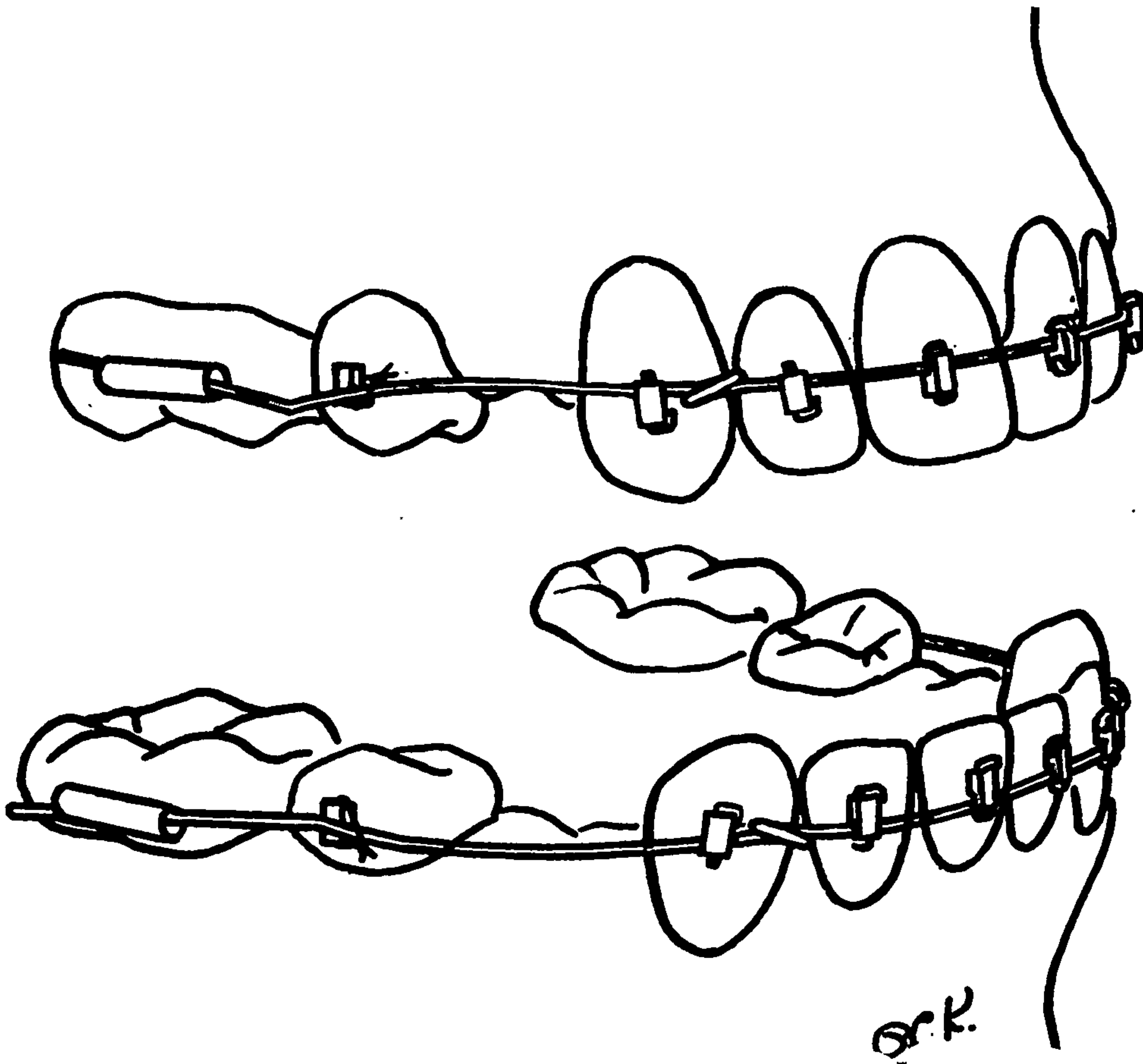

Fig. 2.2

Light round arch wire placed  
on the teeth.

(P.R. Begg 1965) (16)

### 2.3. The Problem

It is observed that the bite opening and anchor bends are sometimes lost (bitten out). This occurs mainly across extraction spaces (Figure 2.3.).

Consequently, the bend properties of the light wire used in this technique are most important, compared with other techniques which use heavier wires.

The loss of force or distortion of wire is often hard to detect in the patient, and only becomes obvious on removing the archwire.

Thus the anterior teeth do not depress rapidly, and anchor teeth may tip anteriorly (Class II Div. I malocclusion).

If the anterior teeth do not depress rapidly the intermaxillary elastics cannot tip the upper anterior teeth distally due to bite interference.

This means an interruption to progress of treatment, and increased treatment time, also it often means a less satisfactory result.

### 2.4 The Archwire

The archwire requires to have the following properties:-

- (a) Sufficiently ductile to have hooks, rings, loops, and offsets incorporated in it.
- (b) Sufficient strength to withstand masticatory stresses without distortion.
- (c) The correct Load-deflection or spring-rate for the technique.

With these requirements in mind it was decided to carry out both tensile and bend tests on several brands of .016 inch diameter wires to predict their performance in this technique.

Specifically the wires were:-

Wilcock Regular

Wilcock Regular Plus

Wilcock Special

Wilcock Special Plus

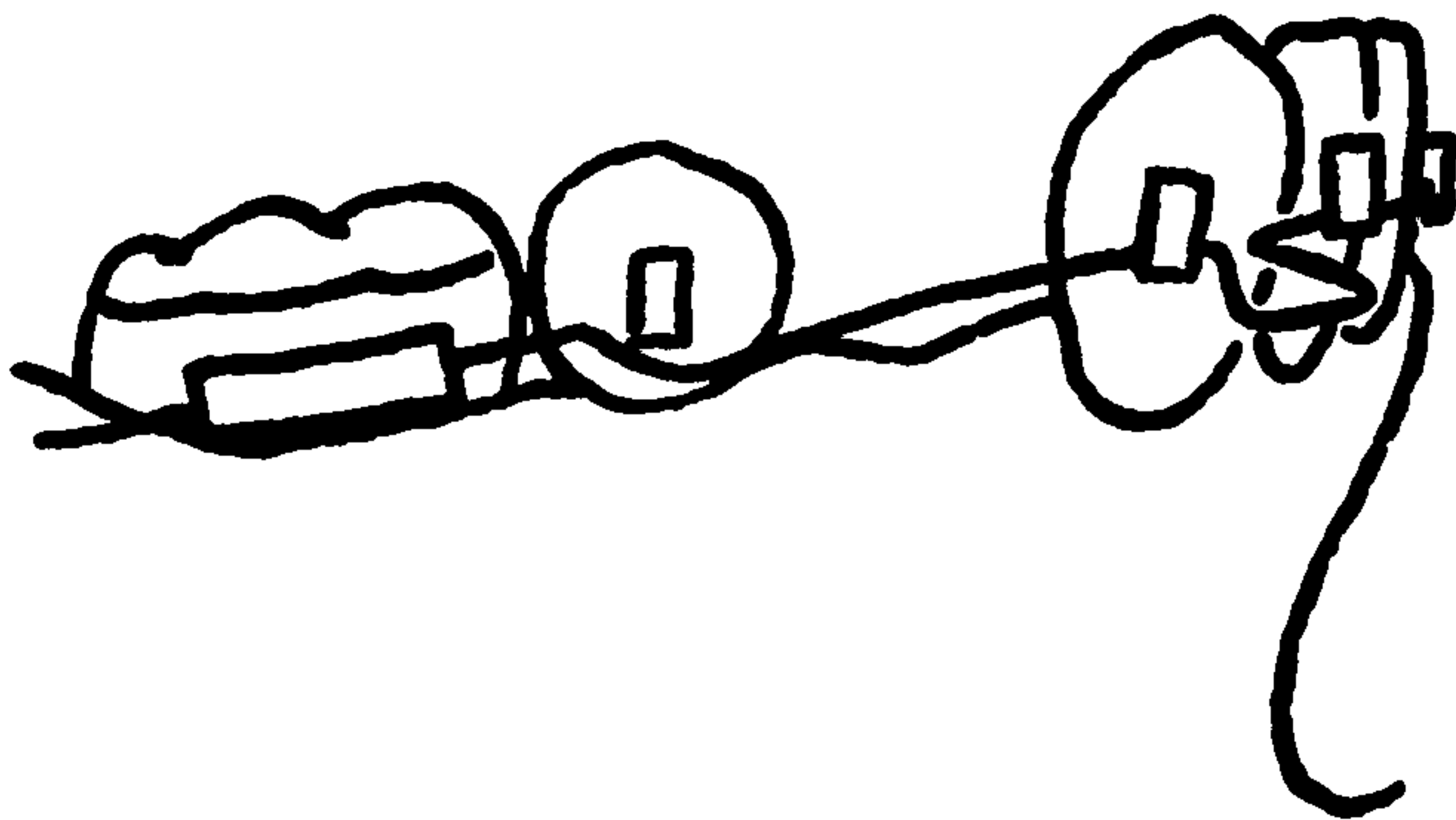

Fig. 2.3

Anchorage bend bitten out by patient. The operator must restore this bend to avoid treatment failure.

(P.R. Begg 1965) (17)

Unisil (Coil)

Unisil (Coil) Heat Treated

Unisil Preform Archwire

Unisil Preform Archwire Teat Treated

Remanit Dentaurem Super Spring Hard

Remanit Dentaurem Super Special Spring Hard

Elgiloy (Red) Heat Treated

It was hoped that the properties to be tested would provide a means of identifying the several wires which would be most suitable for clinical use.

## Chapter 3

### 3. ARCHWIRE MATERIALS

Since Fauchard 1723 (2) introduced his arch bar fashioned from gold or silver, there has been a continuing search for the metal best suited for the treatment plan.

With the development of the principle of arch expansion, the requirements of the metal were rigidity and spring properties.

#### 3.1 Precious Metals

The alloys of gold platinum and iridium were most successful in this respect.

Platinised gold wires had spring properties which made them suitable for use as an arch wire. It could also be employed as a spring member soldered to an archwire to move individual or several teeth.

The rigidity of the archwire could be controlled by heat treatment, use of different alloy, or change of diameter.

Gold alloy wires could be softened and adapted easily to the proper shape and then hardened by an appropriate heat treatment (Paffenbarger 1943) (57).

In addition to required properties being obtainable by heat treatment, attachments could be soldered to the archwire without loss of temper.

Gold alloys were aesthetically acceptable.

#### 3.1.1. German Silver

Gold plated German Silver, together with its various combinations of alloys, could be controlled by heat treatment to provide the required spring properties or rigidity (Pollock 1916) (59).

German Silver could be soldered with a soft solder, and it was also supposed to have a caries inhibiting effect.

The objection to the metal was that the gold plating soon wore off and then its appearance became "offensive", (Pollock) (59).

### 3.1.2. Tungsten

Pollock (59) used and recommended Tungsten drawn into wire and gold plated or gold and palladium plated. Because of its great rigidity and spring properties he was able to use smaller gauge than those of gold or silver. However it was very brittle and difficult to bend. It had to be notched with a stone and then broken like glass rather than cut with pliers.

Also it was unreliable in larger sizes.

It could be soldered like the other metals and the appearance was quite acceptable.

### 3.1.3. Stainless Steel

When Stainless Steel was first used in Orthodontics about 1933 (Gaston 1951) (40) the archwire requirements were much the same. that is

- (a) Spring Properties
- (b) Rigidity
- (c) Soldering
- (d) Aesthetics
- (e) Non-corroding

Stainless steel did not tarnish in any mouth, and so was more acceptable than gold alloys which tended to tarnish in some mouths.

It had great tensile strength and toughness and so could be used in smaller sizes (Friel 1933) (38).

Stainless steel was cheaper than gold. A pound of stainless steel cost 4/6-8/6 according to size and gold £145 (Friel).

The great difficulty with stainless steel in the early stages was with soldering. The joints just would not hold. Also if the steel was overheated in the soldering process it lost its temper and this could only be restored with cold working (Paffenbarger) (57).

Gold certainly seemed to be superior in the field of heat treatment and

soldering.

However suitable solders and fluxes have been developed to make stainless steel soldering more successful these days.

### 3.2 Light wire Techniques

Robinson (60) used light wires of platinised gold and tungsten in 1918. Platinised gold in the small gauge lost its rigidity (Pollock) (59). Tungsten was far too brittle.

Stainless steel had great strength and ductility in the smaller gauges and above all it did not require soldering when used in light wire techniques. This meant no accidental loss of its properties due to heat.

It would seem that stainless steel had more to offer the light wire technique than any other metal.

But many grades of stainless steel have been developed.

Stainless steel suitable for Orthodontic use in America were grades 302, 304, 316. (18.8 Type see 6.1.2.)

There were precipitation hardened stainless steels.

There were also cobalt chrome nickel steels.

With all these types of wires available it was inevitable that people would want to test their properties.

The Orthodontist wants to know all the properties of all the wires available so that he can select that one most suitable for his technique.

### 3.3. Testing of Wires

Testing of wires was first attempted with the alloys of gold.

Then there were many tests comparing the properties of stainless steel and gold.

For many years, when stainless steel was presenting difficulty with soldering, gold was the metal of choice.

When a clinician becomes skilled in the use of a particular metal, he is often loath to change for marginal improvements.

Eventually most tests were carried out on chrome-nickel, or cobalt-chrome-nickel alloys.

One of the first persons to attempt to make a comparison of the properties of orthodontic wires was a metallurgist named Williams 1923 (24).

He said that more time should be devoted to study of the physical properties of wires for orthodontic use.

He compared various gold wires using piano wire as a standard, and attempted to translate the desirable orthodontic properties of wires into actual tangible figures of stress and strain.

Also he designed an instrument to determine the suitability or not of orthodontic wires based on the elasticity of the material tested.

However, before the physical properties of metals and structures can be tested and discussed, it is necessary to present the terminology and theoretical principles involved. Definitions, unless otherwise stated, are taken from Metals Handbook (1961).

## Chapter 4

### 4. ELASTICITY AND STRENGTH OF MATERIALS

---

#### 4.1 Stress Strain and Elasticity (Salmon) (63)

##### 4.1.1. Elastic Material

When making an analytical study of the effect on a body of distorting forces it is customary to assume that the material of which the body is composed is perfectly elastic. That is to say, it is assumed that, not only do all effects of the distorting forces immediately disappear on removal of those forces, but that the distortion produced in the material is proportional to the magnitude of the effort which gives rise to it. It is further assumed that the material has the same elastic properties in every direction. Such material is called isotropic-material. No engineering material completely satisfies this deal, but many approximate closely to it if the distortion produced be not too great. The following theory can be safely applied to these materials provided that a certain limit, called the elastic limit, be not overstepped. This limit is discussed in 4.1.6.

##### 4.1.2. Tensile Stress and Strain

Suppose that a bar of length  $l$  be subjected to two longitudinal forces,  $FF$ , directed along its axis, as shown at (i) Fig. 4.1. Careful measurement will show that, as a result, the bar has lengthened by a certain amount which will be denoted by  $\delta l$ . This alteration in length  $\delta l$  is called the extension produced by the forces  $FF$ . The ratio

$$\frac{\text{extension}}{\text{original length}} = \frac{\delta l}{l} = s \quad \text{--- (1)}$$

is termed the strain. Evidently the strain is the alteration of length per unit of length of the bar, for if  $l = 1$ ,  $s = \delta l$ .

Owing to the action of the external forces  $FF$ , stresses will be set up in the material of the bar, and, at any cross section such as  $KK$  (ii. Fig 4.1.) if

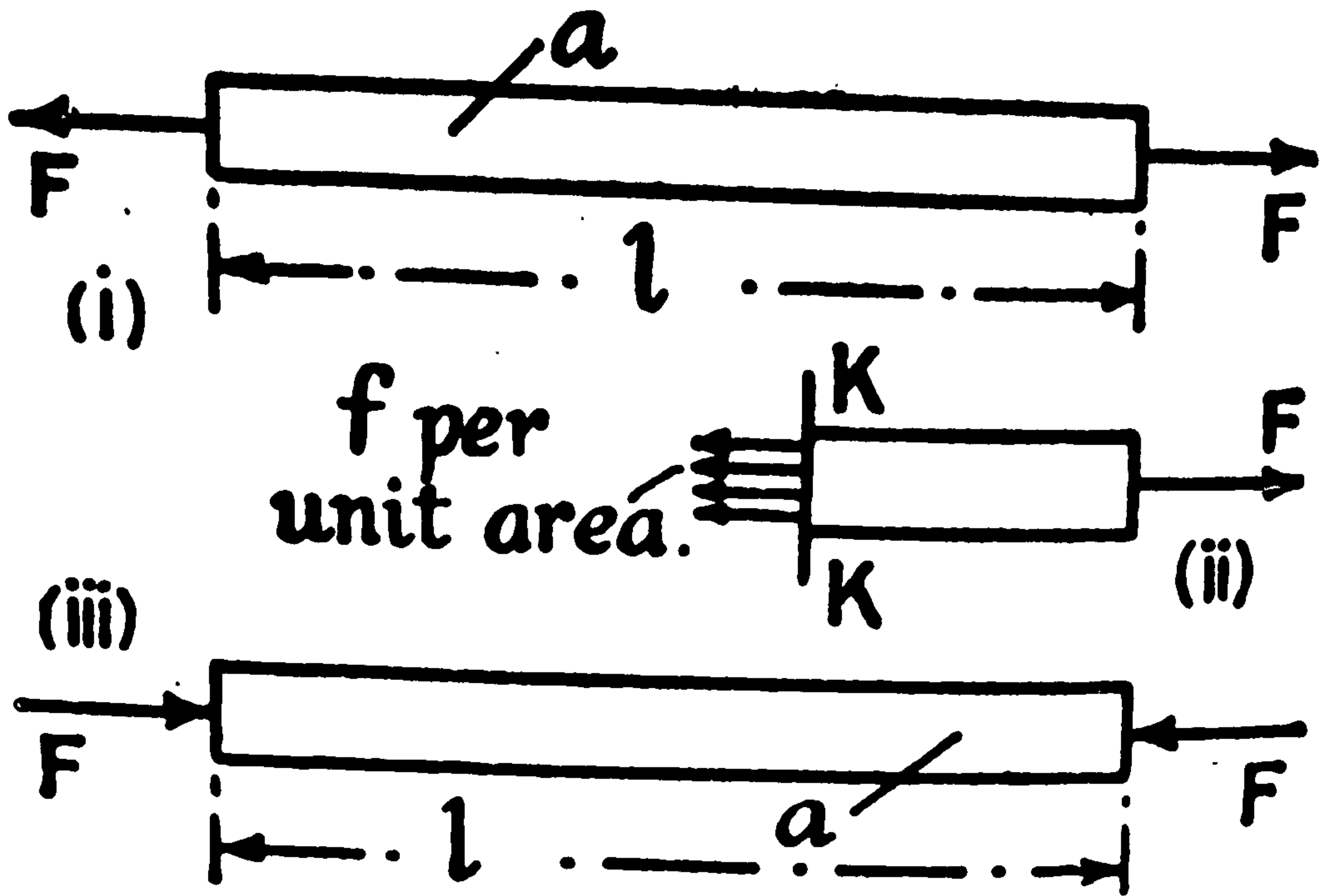

Fig. 4.1 Forces on a Longitudinal Bar.

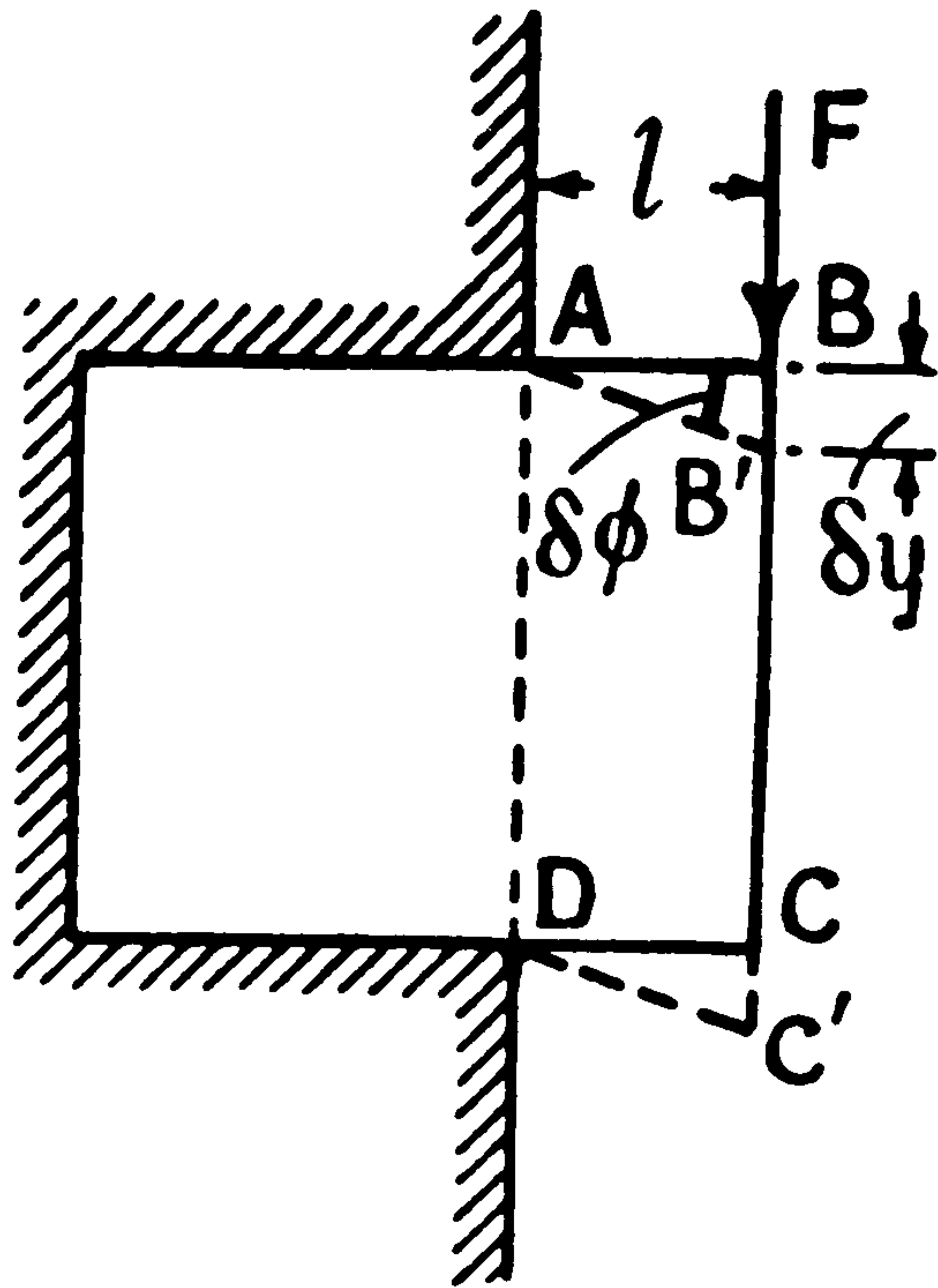

Fig. 4.2 Shear Forces on a Rigid Bar.

the area be  $a$  and the intensity of molecular force or stress produced be  $f$  per unit area, it is evident that for equilibrium

$$F = af, \text{ or } f = \frac{F}{a} \quad \text{--- (2)}$$

By the expression stress, therefore, is to be understood the intensity of internal force called into play by the external forces. This intensity is expressed as units of force per unit of area. Thus, if the forces are expressed in tons, and the area  $a$  in square inches, the stress produced is expressed in tons per sq. in. Since, in the example under consideration, the chief deformation produced is an extension, the bar is said to be in tension, the stress is a tensile stress, and the corresponding strain a tensile strain.

In elastic material the ratio of stress to strain is constant, a relation known as Hooke's law after its discoverer. This ratio is called the Modulus of Elasticity. Hence,

$$\frac{\text{Stress}}{\text{Strain}} = \frac{f}{s} = \frac{f \cdot l}{\delta l} = \text{constant} = E \quad \text{--- (3)}$$

where  $E$  is the Tensile Modulus of elasticity, often called Young's Modulus.

It follows therefore that

$$\frac{f}{E} = \frac{F}{Ea} = \frac{\delta l}{l}, \text{ or } \delta l = \frac{Fl}{Ea} \quad \text{--- (4)}$$

The magnitude of  $f$  and  $E$  must be expressed in the same units. If the stress be expressed in lbs per square inch, the modulus of elasticity must be expressed in lbs per square inch.

The value of the modulus of elasticity is different for different materials.

The above equations are strictly true if the stress over the cross section be uniform. If, as is often the case, the stress is not uniformly distributed, eq (2) expressing the intensity of stress at any point must be written  $f = \frac{\delta F}{\delta a}$ , where  $\delta F$  is the amount of the molecular force on a indefinitely small area  $\delta a$ .

Alternatively, in such a case as Fig. 4.1.,  $f$  in equation (2) may be regarded as the average stress over the cross section.

Young's modulus or the modulus of elasticity is a measure of the stiffness or rigidity, the higher its value the greater the stress needed to produce a given deformation and the stiffer the material (Earnshaw) (36).

#### 4.1.3. Compressive Stress and Strain

If the direction of the application of the forces  $FF$  be reversed, the bar will be in compression instead of in tension (iii Fig.4.1.) The alteration of length will be a contraction instead of an extension, and the stress and strain produced will be a compressive stress and compressive strain respectively. The ratio of compressive stress to compressive strain will be the compressive modulus of elasticity which may be taken as equal to  $E$ , the tensile modulus.

The same relations and equations will hold for compressive stress and strain as for tensile - in fact one may be regarded as a negative form of the other.

Pure tensile and compressive stresses and strains are sometimes called simple stresses and strains, for any state of stress and strain can be reduced to combinations of such simple stresses and strains.

#### 4.1.4. Shear Stress and Strain

Suppose  $ABCD$  to be a projecting length  $l$  of a body rigidly held at  $AD$  and acted on by a force  $F$  at  $B$ , as shown in Fig. 4.2. It will be assumed that the length  $l$  is so short that the bending set up is negligible. Under the action of the forces  $F$  the body will deform, the rectangle  $ABCD$  becoming the parallelogram  $AB'C'D$ . This kind of deformation is termed shearing and angle  $BAB' = \delta\phi$ , which is a measure of the deformation, is called the shear strain. The angle  $\delta\phi$  is expressed in radians, and, since it will be very small,  $\delta\phi = \frac{BB'}{AB}$ . If  $a$  be the area of cross section of the body, the average intensity of the shear stress is  $f_s = \frac{F}{a}$  and, as in the case of tensile and compressive stress and strain, it is

found that, in elastic material, the ratio of shear stress to shear strain is constant.

Hence,

$$\frac{\text{Shear Stress}}{\text{Shear Strain}} = \frac{f_s}{\delta\phi} = \text{constant} = G \quad \text{--- (5)}$$

or  $\delta\phi = \frac{f_s}{G}$ , Where  $G$  is the modulus of elasticity in shear, often called the modulus of rigidity, a quantity corresponding to the tensile modulus  $E$ , but not equal to it. Eq. (5) may be written

$$\frac{f_s}{G} = \frac{F}{Ga} = \delta\phi = \frac{\delta y}{l} \quad \text{--- (6)}$$

Where  $BB'$  is denoted by  $\delta y$ .

#### 4.1.5. The Stress-Strain Relationship

The stress-strain relationship (Earnshaw 1967) (36) of a wire in tension is shown in Figure (4.3.) (Earnshaw) (36). Assuming the wire is made of some non ferrous metal, if it is loaded gradually in small increments, and if measurements are made of the extension produced by each increment, then a series of readings can be obtained, of load against extension, right up to the breaking load.

Knowing the original cross-sectional area of the wire, loads can be converted to stresses and similarly, from the original length, extensions can be converted to strains. The results obtained from loading the wire enable us to plot stress against strain for each load increment, and so draw a stress-strain curve for that material. A typical stress-strain curve for the material specified is shown in Figure (4.4.). From a stress-strain curve like this we can define many properties which are important in the consideration of metals and alloys under load.

The first part of the stress-strain curve,  $OA$  in Figure (4.4.) is substantially a straight line. The material is obeying Hooke's law and its behaviour is elastic.

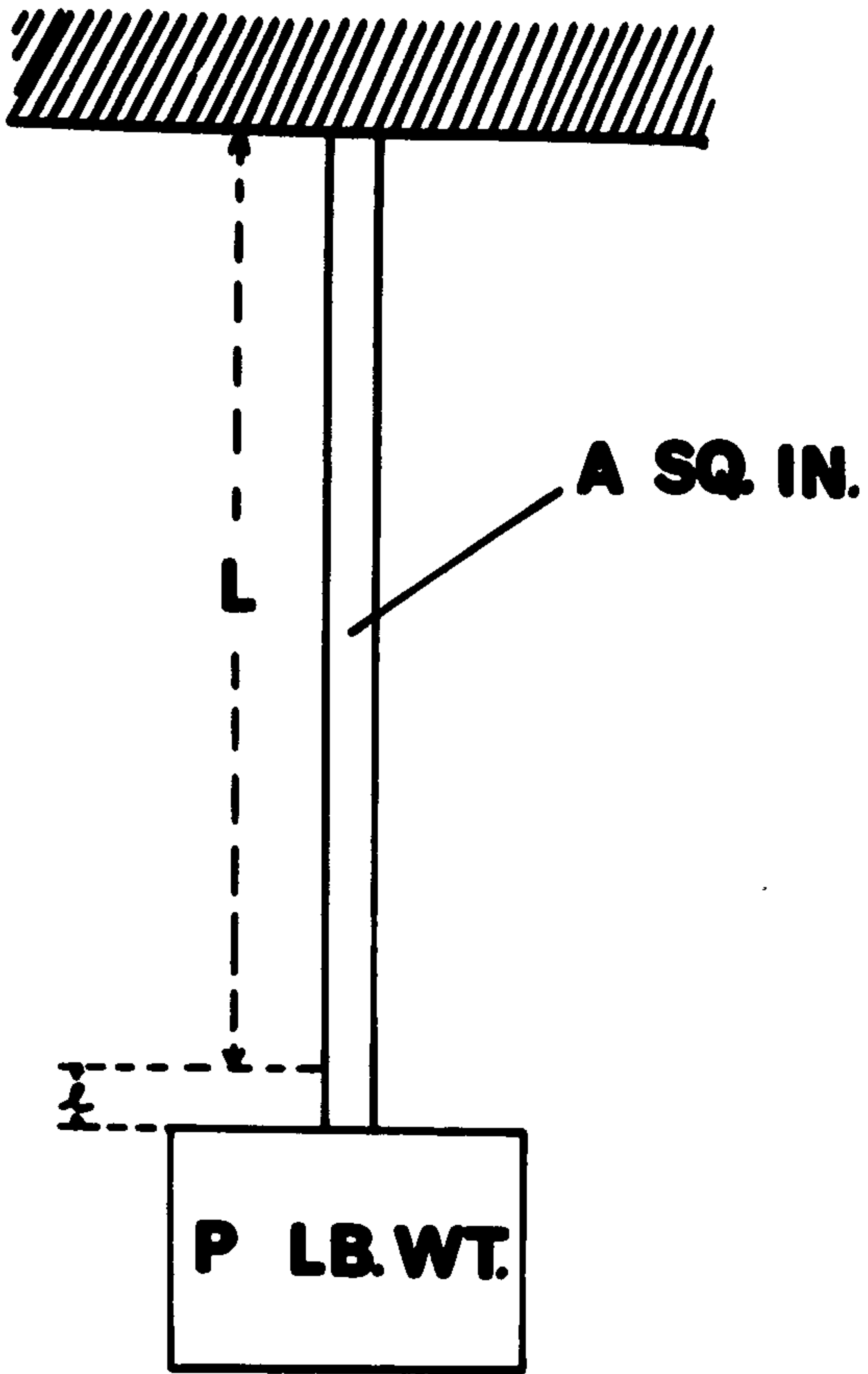

Fig 4.3 Wire in Tension.

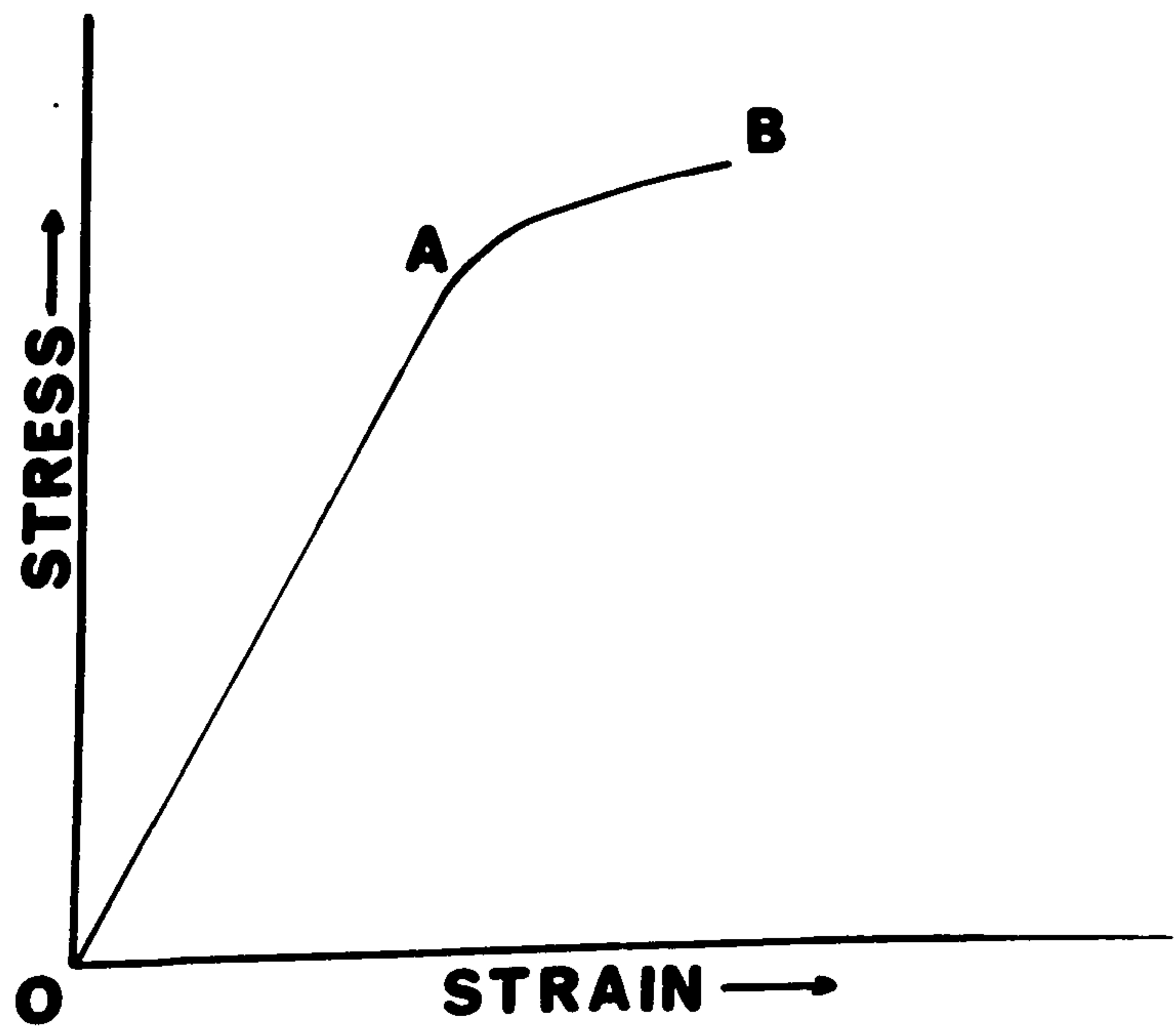

Fig. 4.4 Typical Stress-Strain Curve.

We call OA the elastic range; stresses in this range are elastic stresses; and we can say that only elastic deformation has taken place. If the load is removed at any time in the range OA, to all intent and purpose the strain returns to zero. If loads are re-applied, the new stress-strain curve follows the original one (i.e. the material is elastic).

Beyond the point A, the relationship between stress and strain is no longer linear. Hooke's law no longer applies, and the behaviour of the material is no longer elastic.

The point A is called the proportional limit or the elastic limit.

Proportional limit can be defined as the maximum stress at which stress is proportional to strain.

Plastic deformation is occurring in the range A-B but elastic strain is still present. If the load is removed at some stage in the plastic range, elastic recovery or "spring back" occurs. E. g. in Fig 4.5., if the load is removed at C the material recovers along the line C-D, parallel to the original elastic section O-A. Thus, after the load is removed there is still some strain present measured by O-D, this represents the plastic deformation performed in the section A-C of the stress-strain curve, and is called permanent set, and is defined as the plastic deformation that remains upon releasing the stress that produces the deformation.

If the material is then reloaded, the unloading curve is retraced from D to C. After the point C is reached, the stress-strain curve continues along C-B, just as if the original loading had not been interrupted.

4.1.6. Elastic Limit The elastic limit is the maximum stress to which a material may be subjected without any permanent strain remaining upon complete release of stress.

The term "elastic limit" has been very loosely employed (Salmon) (64). It is sometimes used to denote -

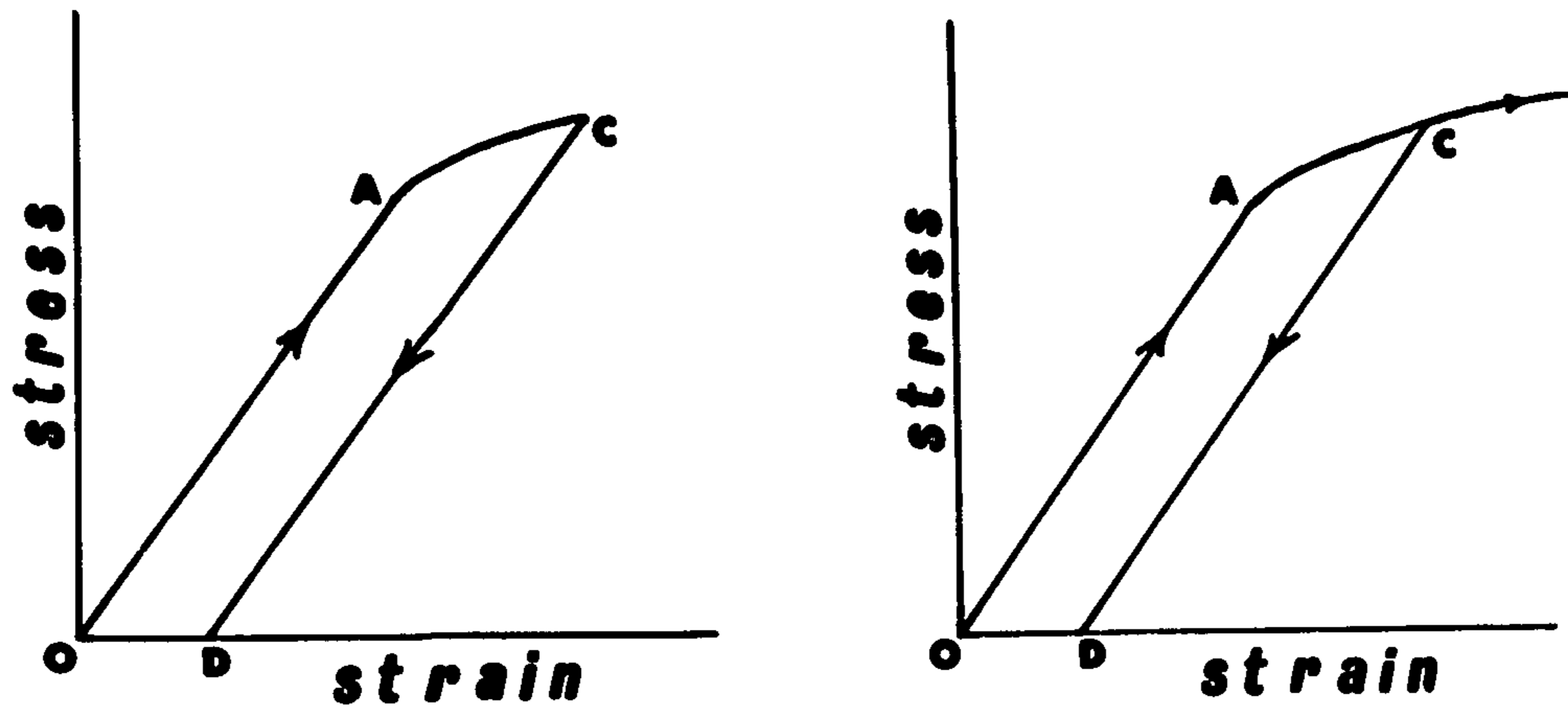

Fig. 4.5 Stress-Strain Curve, Plastic Deformation.

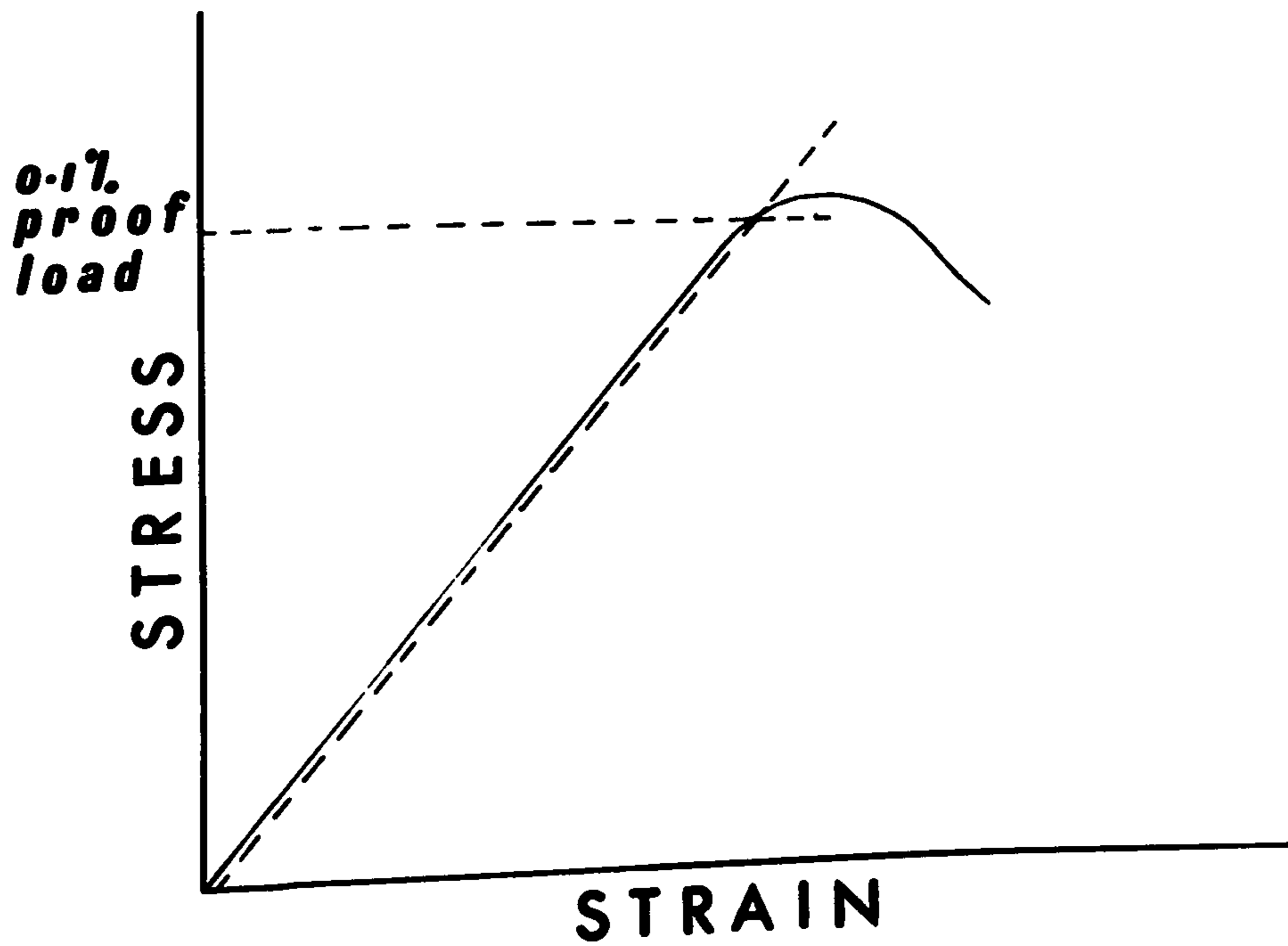

Fig. 4.6 Stress-Strain Curve Proof Stress.

- (i) The limit within which the deformation entirely disappears when the load is removed.
- (ii) The limit below which the elongation is proportional to the load.
- (iii) The yield point, or as it is often called the "commercial elastic limit".

In recent years (iii) is usually called the proportional limit. In mild steel it differs very little from (i). Very refined measurement, however, has shown that materials are only perfectly elastic under very low loads, for most materials very early develop minute permanent sets. Some experimenters have therefore given very low values for the elastic limit, but the term "proportional limit" is usually used to denote the point at which marked divergence from proportionality first appears. To avoid confusion it is better to speak of the "proportional limit" and "yield point" and not use the terms "elastic limit" and "commercial elastic limit".

4.1.7. Yield Point The yield point is the first stress in a material, usually less than the maximum attainable stress at which an increase in strain occurs without any increase in stress. Only certain metals exhibit a yield point. If there is a decrease in stress after yielding, a distinction may be made between upper and lower yield points.

4.1.8. Yield Stress (Earnshaw ) (38). In order to get reproducible results, the stress is determined which produces a small, definite plastic strain. This will be a definite fixed point on the stress-strain curve, irrespective of how sensitive the measurements are. In effect, we select a very small but easily measurable plastic strain and say that any plastic deformation less than this is not serious. There are two common methods of assessing yield stress.

- (a) The load is added in equal increments, and the stress noted at which a load increment first causes a strain 25% greater than the strain caused by that increment at the beginning of the test.

(b) The stress-strain curve is plotted as usual, and then a point is found on it corresponding to a definite plastic strain or permanent set. The limit often chosen corresponds to a permanent set of 0.001 i.e. of 0.1%.

The stress necessary to produce this permanent set of 0.1% is called the 0.1% proof stress. It is easily found by drawing what is called an offset line on the stress-strain curve. Fig. 4.6.

In this case the offset line starts from a strain of 0.001 and is drawn parallel to the straight line part of the stress-strain curve. The point where it intersects the stress-strain curve corresponds to a permanent set of 0.001 (or 0.1%) and the stress at that point is the 0.1% proof stress.

Sometimes a 0.2% proof stress is determined instead of 0.1% or sometimes a smaller permanent set is defined, e.g. 0.02% or even 0.01%.

Thus there are two ways in which the yield stress can be measured. Both methods give similar results, since both are based on finding the stress which causes a small but easily measured plastic strain.

Yield Strength or Yield Stress can be defined as the stress at which a material exhibits a specified deviation from the proportionality of stress and strain. An offset of 0.2% is used for many metals.

4.1.9. Proof Stress is described as

- (1) The stress that will cause a specified small permanent set in a material.
- (11) A specified stress to be applied to a member or structure to indicate its ability to withstand service loads.

4.1.10. Ultimate Tensile Strength is the maximum tensile stress that a material can withstand.

Manufacturers tend to supply ultimate tensile strength data, and not information on elastic properties. This is probably because it is more easily obtained.

The Orthodontist on the other hand in designing a structure is just as interested in the elastic as the plastic properties.

Consequently experimenters with orthodontic wires have tried to find a relationship between ultimate tensile strength and proportional limit.

Bilberg (1962) (20) suggested that hard drawn stainless steel wires should have a proportional limit of eighty five percent of their tensile strength. For spring hard (high) tensile wires, ninety per cent is suggested.

Delgado and Anderson (1963) (33) on tests on 18.8 stainless steel wires found that proportional limits ranged from 61 per cent to 87 per cent of the ultimate tensile strength.

Wilkinson (1962) (81) in his work with stainless steel wires of different diameters, and from different manufacturers found that ultimate tensile strength cannot be used as a reliable measure for proportional limit.

Wilkinson did also find that ultimate tensile strength increases as the diameters of the wire is reduced, drawing condition being equal. (This phenomenon is probably due to the relative depth of the plastic deformation as the process of drawing causes pressures to be applied to the surface of the wire, its central core being the least area affected (Wilkinson) (81)).

4.1.11. Ductility is the ability of a material to deform plastically without fracturing, being measured by elongation or reduction of area in a tensile test.

Salmon (65) states that one way to assess ductility is to measure the total strain at fracture as a percentage and this gives the percentage elongation and gives an idea of the relative ductilities of different materials.

4.1.12. Toughness is the ability of a metal to absorb energy and deform plastically before fracturing.

It is usually measured by the energy absorbed in a notch impact test (Salmon) (66), but the energy under the stress-strain curve in tensile testing is also a measure of toughness.

(Metals Handbook) (51).

If the amount of energy involved is large the material is tough. If the energy is small the material is brittle (Earnshaw) (36).

4.1.13. Beams (Earnshaw) (36) A simple beam is one supported at each end, and loaded in the centre (Figure (i) 4.7.).

When a simple beam bends, there will be a neutral layer where the stress is zero. This can be imagined as an infinitely thin, horizontal layer through the centre of the beam. All parts of the beam below the neutral layer will be in tension, and all parts above the neutral layer will be in compression.

In both cases, the stress increases with the distance from the neutral layer, and is at a maximum on the surface. In addition to those longitudinal stresses, shear stresses are set up as well, as a result of shear forces between the load and the supports.

A Cantilever beam is one which is clamped at one end, and loaded at the other (Figure (ii) 4.7.). There is a neutral layer as before, and again the beam is in tension on one side of the neutral layer, and in compression on the other, and obviously shear stresses will be set up as well.

A clamped or encastré beam is one which is clamped rather than just supported at each end. (Figure (iii) 4.7.).

Here the bending is more complex. There is still a neutral layer, but the stresses on each side of it change in sign from section to section of the beam. Again, shear stresses are set up as well.

4.1.14. Strain Energy : Resilience Resilience can be defined as :-

- (i) The amount of energy per unit volume released upon unloading.
- (ii) The capacity of a metal, by virtue of its high yield strength and low elastic modulus, to exhibit considerable elastic recovery upon release of load.

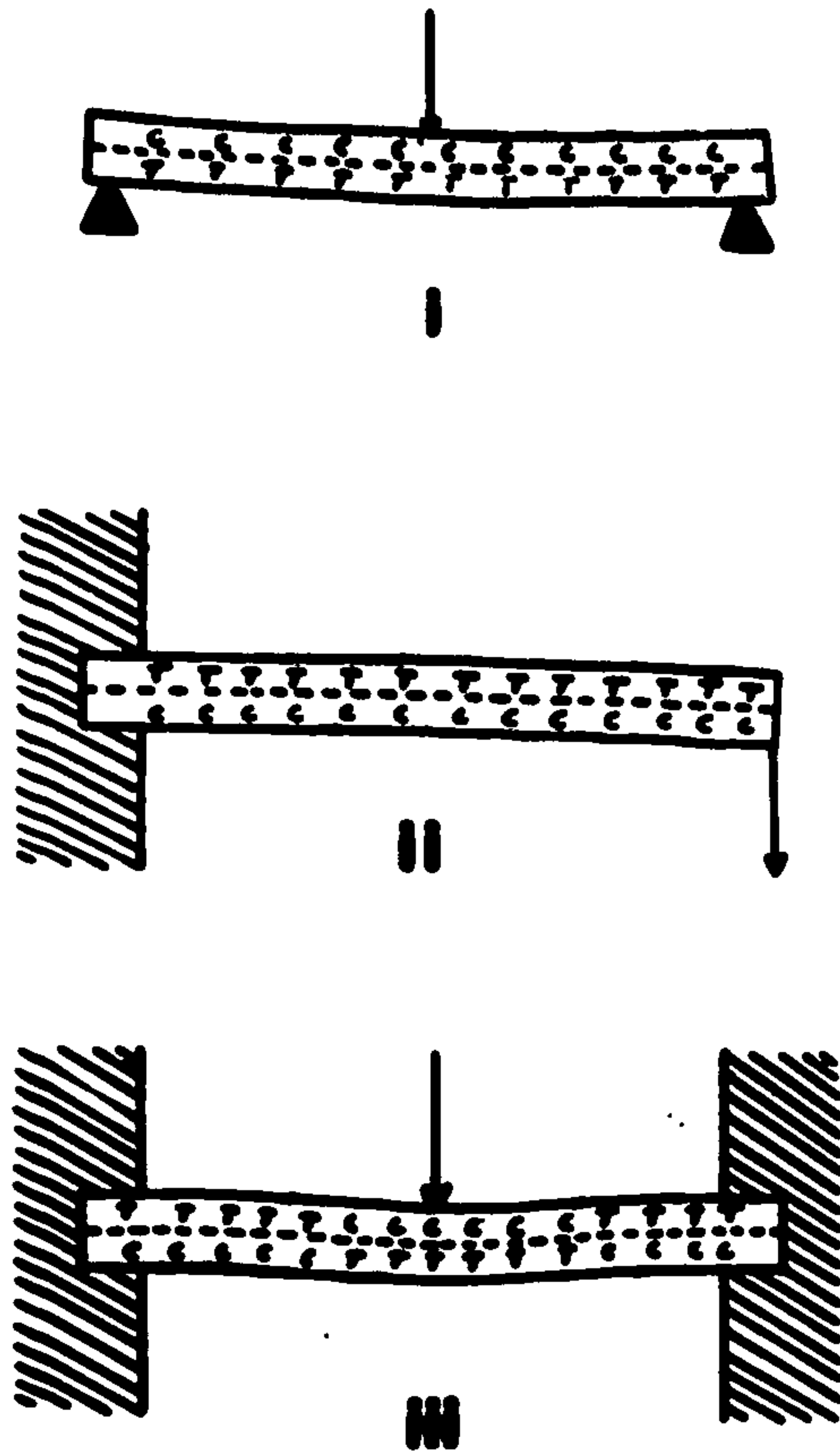

Fig. 4.7 Beams-Bending

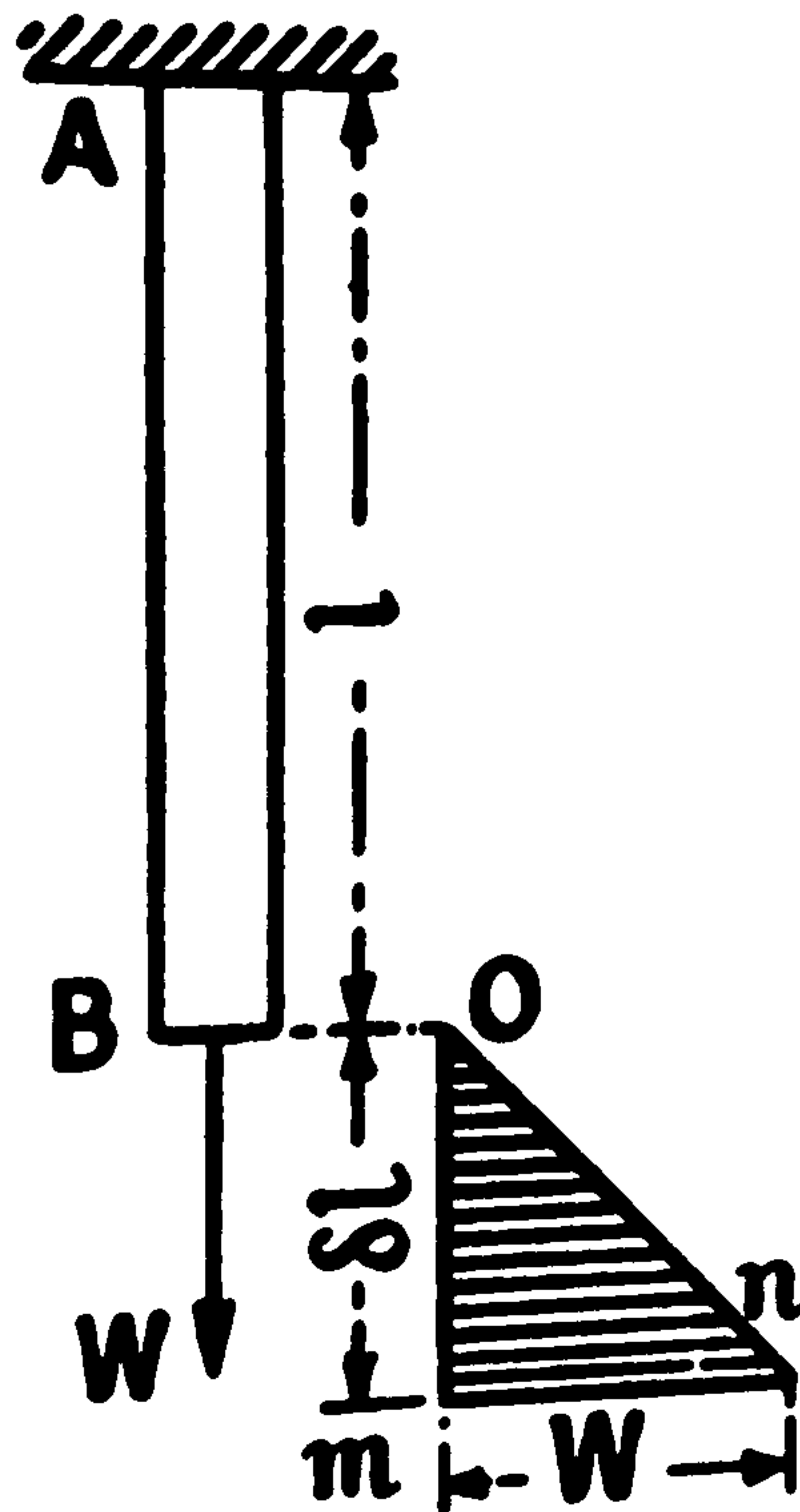

Fig. 4.8 Work done in Stretching a Bar.

Work done in Stretching a Bar (Salmon) (67). Let A B (Figure 4.8.) be a bar of length  $l$ , attached at its upper end A, and loaded at its lower end B, with a tensile force which gradually increases from zero to some value  $W$ . As the load increases the bar will lengthen; and, while the material remains elastic, the stress will be proportional to the strain. Therefore the increase in length  $\delta l$  will be proportional to the load  $W$ . The triangle  $o m n$  will represent the relation between  $\delta l$  and  $W$ , that is to say, the increase in  $l$  for increasing the value of  $W$ . Now the work done by the load in stretching the bar is equal to the average force  $W/2$ , multiplied by  $\delta l$  the distance moved. Hence the work done is  $\frac{1}{2}W \delta l$  which is equal to the area of the triangle  $o m n$ . This energy is stored up in the bar and is called the strain energy. If the area of the bar be  $a$ , and the stress due to load  $W$  be  $f$ , then  $W = f a$ . Further, the stress is equal to  $E \times$  strain, and the strain is  $\frac{\delta l}{l}$ , therefore  $f = E \frac{\delta l}{l}$ , and  $\delta l = \frac{f l}{E}$ . If  $U$  be the strain energy,  $U = \frac{1}{2}W \cdot \delta l = \frac{1}{2}f a \frac{f l}{E} = \frac{f^2}{2E} \cdot a l = \frac{f^2}{2E}$  (volume of the bar), for  $a l$  is the volume of the bar. This is an expression for the work stored up in the bar, or as it is sometimes called, the internal work.

Resilience. If the load  $W$  be increased until the stress  $f$  reaches the limit of elasticity of the material, the strain energy then stored up in the bar will be the maximum amount of work which can be done on the bar without permanently deforming it. This amount of work is called the resilience of the bar. The load producing this stress is called the proof load  $W_p$  and the stress is called the proof stress  $f_p$ . If  $U_p$  be the resilience,

$$U_p = \frac{f_p^2}{2E} \quad (\text{volume of the bar})$$

The resilience is a measure of the capacity of the member to store up work, and therefore of its capability to resist shock, without plastic deformation, for should the bar sustain a blow, the energy imparted to it by the shock must not exceed the resilience, or the bar will be permanently deformed.

Wahl (77) considers the above case to be an ideal spring. Since the bar is loaded axially, the stress distribution across the section is uniform and for this

reason this case represents the optimum condition from the view point of maximum storage per unit volume of material.

#### 4.2. Bending Moments and Shearing Forces (Salmon) (68).

Let A B (figure 4.9.) be a cantilever projecting from a wall, and suppose that a couple  $M$  be applied at A. The effect of this moment will be to bend the beam as shown in the figure. Such a moment is called a bending moment. It is evident that a similar effect will be produced if, instead of the couple, a vertical load  $W$  be applied at A (figure 4.10.).

Consider any section K at a distance  $x$  from W. The equilibrium of the portion A K of the beam((ii) figure 4.10.) will not be affected if two equal and opposite forces, of the same magnitude as  $W$ , be applied to the beam at K.

If the upward force  $W$  at K be considered in conjunction with the downward force  $W$  at A, the two forces evidently form a couple of magnitude  $W_x$ , and this couple will cause the beam to bend, just as did the couple  $M$  in figure 4.9. The moment  $W_x$  of the couple is evidently the bending moment on the beam at the section K.

There still remains the third force  $W$ , at K, to be taken into account. This will tend to slide the portion A K of the beam downwards, relatively to the remainder, as shown at (iii) figure 4.10. It tends in fact to shear the beam at K, and is the shearing force at that section.

The load  $W$  at A, therefore, has two effects on the beam at a section such as K. It produces a bending moment which curves the beam, and a shearing force which tends to shear the beam.

Next, suppose that there be more than one load on the cantilever (figure 4.11.), say  $W_1$  at a distance  $x_1$ , from K and  $W_2$  at a distance  $x_2$  from K. As before, consider the equilibrium of the portion A K (ii figure 4.11.), and suppose that two equal and opposite forces of magnitude  $(W_1 + W_2)$  act at K.

There are, then, two couples acting on the portion A K, of which the moments are  $W_1 \cdot x_1$  and  $W_2 \cdot x_2$ , and the total bending moment at K is  $(W_1 \cdot x_1 + W_2 \cdot x_2)$  or the sum of the moments due to  $W_1$  and  $W_2$  considered deparately. Further the shearing force at K is evidently  $(W_1 + W_2)$  or the sum of the loads  $W_1$  and  $W_2$ .

If  $W_2$  act in the reverse direction to  $W_1$  (iii figure 4.11.), it is evident that it would produce a moment and a shearing force of the opposite kind to that produced by  $W_1$ . If the kind of bending and shearing produced by  $W_1$  be considered as positive, that produced by  $W_2$  must be considered as negative. Figure 4.12. represents positive and negative bending and shearing. These signs are, of course, merely conventions.

By extension from the above reasoning, when all the forces are perpendicular to the beam, the bending moment at any section of the beam may be defined as the algebraic sum of the moments about that section of all forces acting on the beam to the right (or, alternatively, to the left) of the section; and the shearing force at any section of a beam may be defined as the algebraic sum of all the forces acting on the beam to the right (or, alternatively, to the left) of the section.

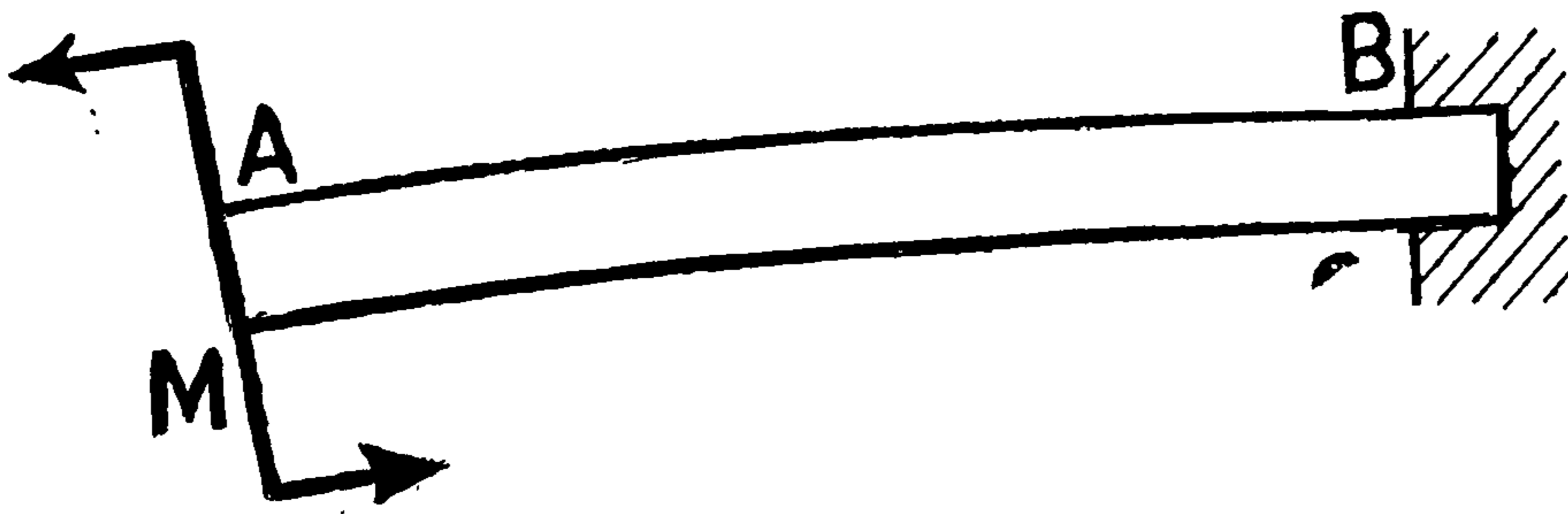

Figure 4.9 Bending Moment of a Cantilever Beam.

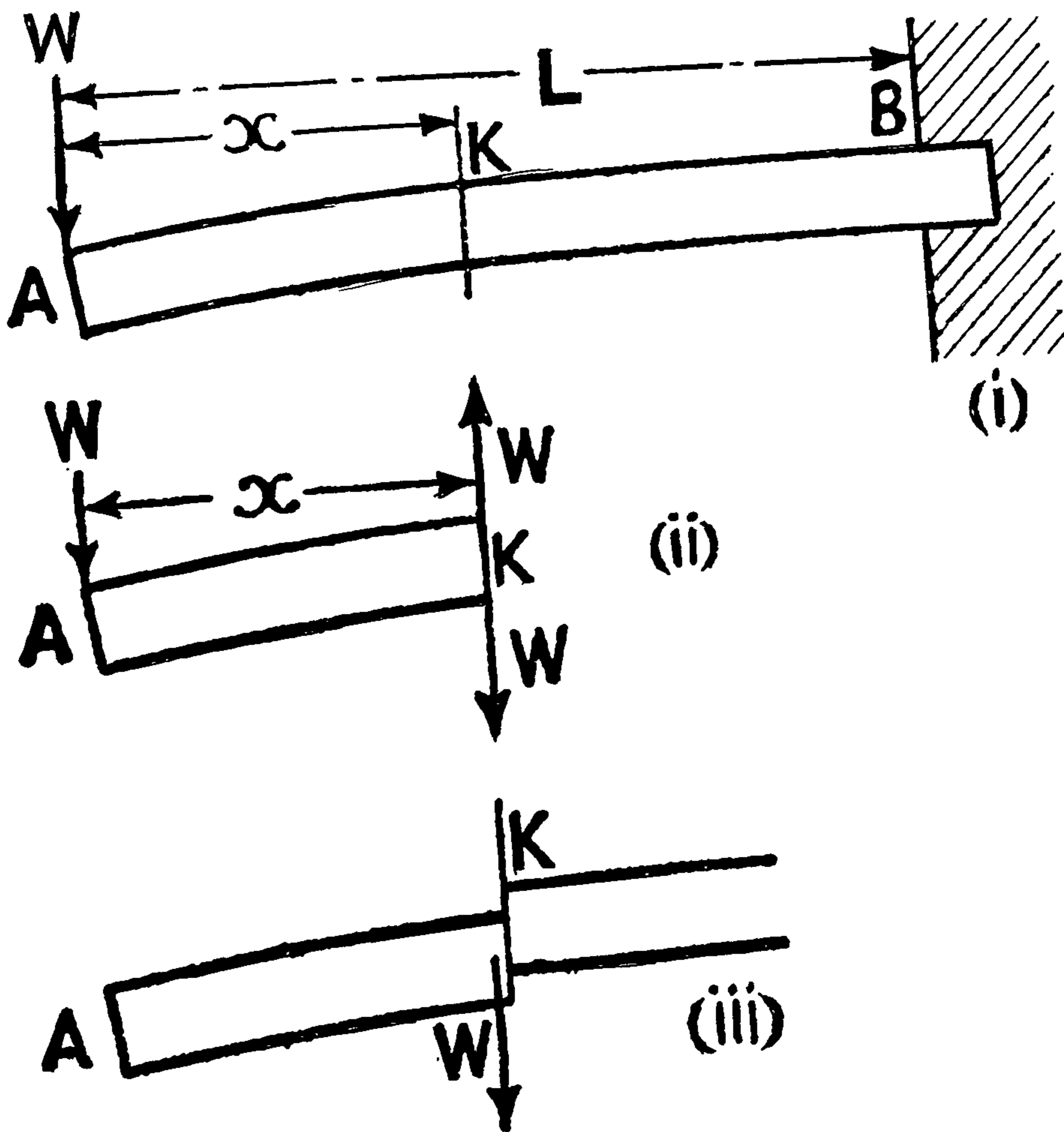

Figure 4.10 Effect of a Load on a Cantilever Beam.

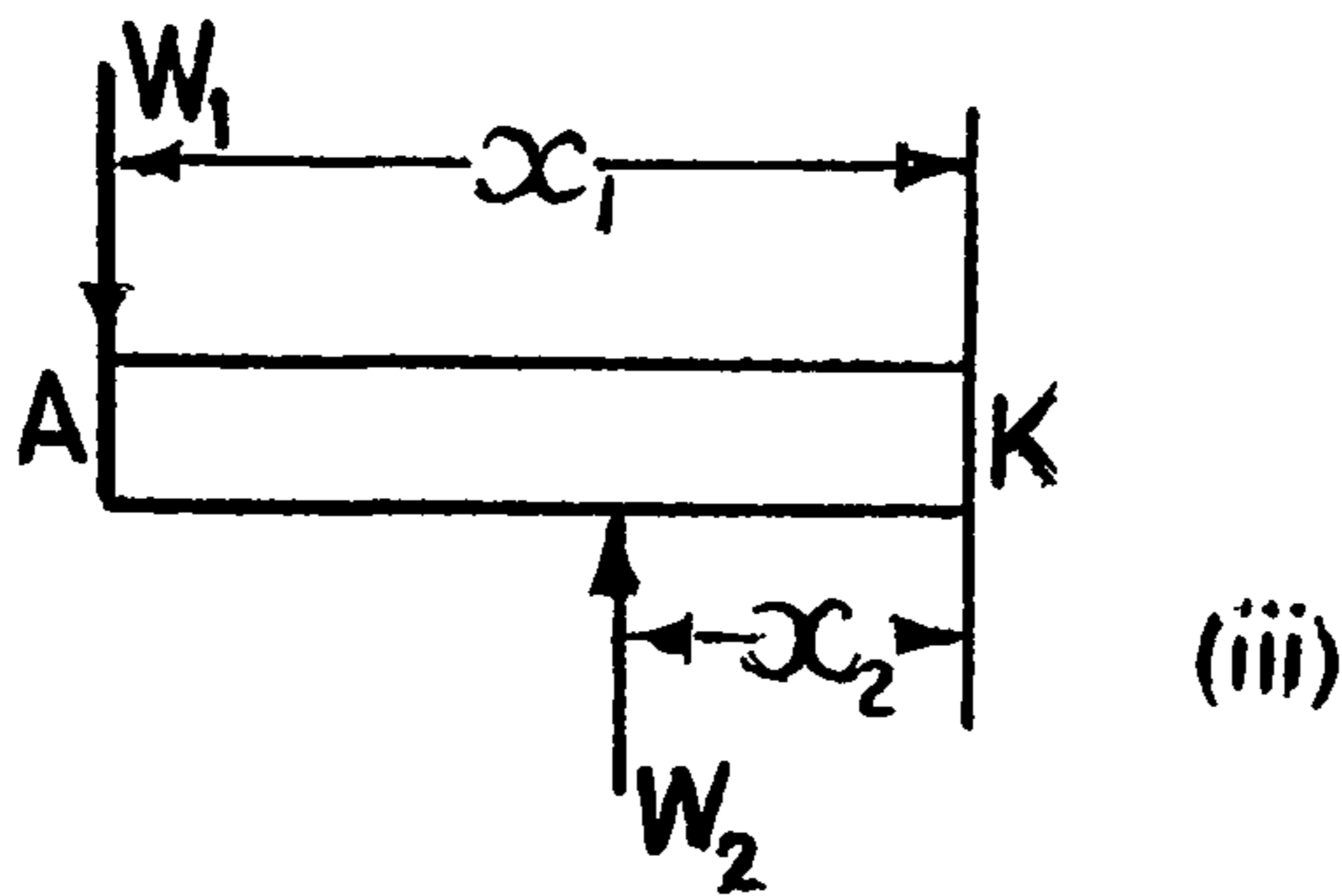
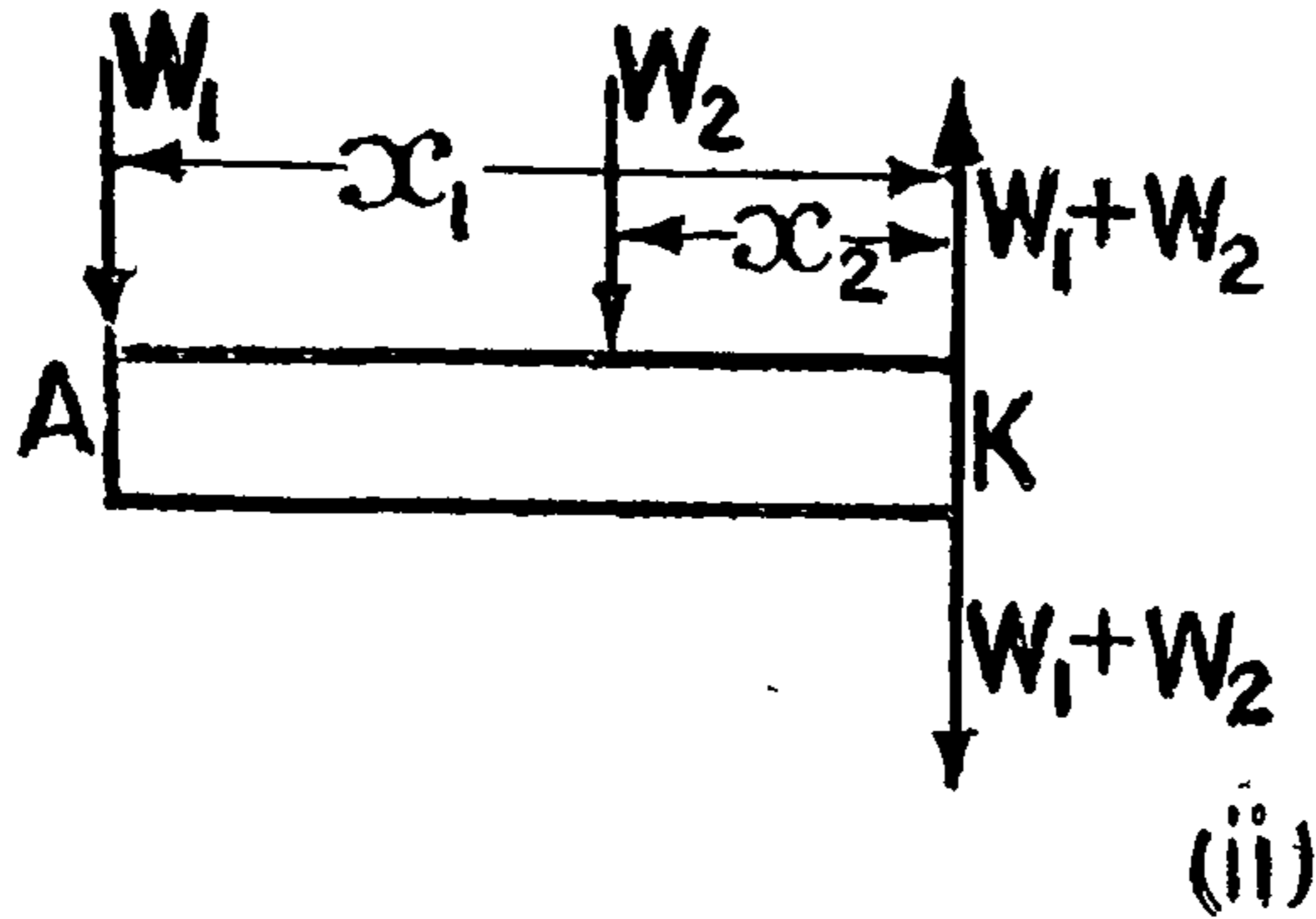
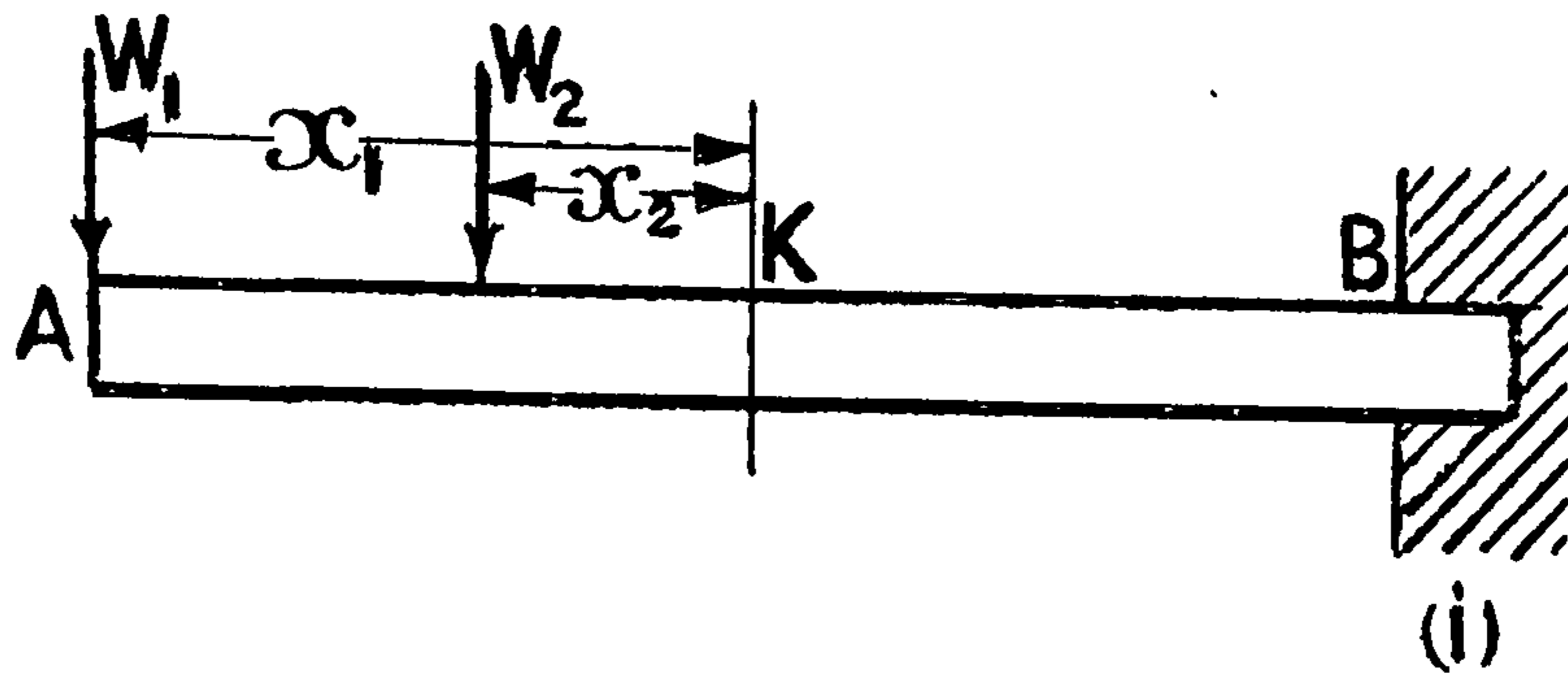

Figure 4.11

Effect of more than one Load on a Cantilever Beam.



Figure 4.12

Positive and Negative Bending and Shearing.

### 4.3. Stresses Due to Bending (Salmon)(68).

#### 4.3.1. The stresses on a Cross Section, Uniplanar Bending.

Suppose  $K_0 J_0$  (Figure 4.13) to be a small element of length in a beam originally straight. A bending moment  $M$  acts on the element, distorting it in shape to  $K_1 J_1 J_2 K_2$ . It will be assumed that the plane sections of the beam remain plane after bending. That is to say, the plane sections  $K_1 K_0 K_2 J_1 J_0 J_2$  which are perpendicular to the curved axis of the beam, were plane sections of the beam before distortion, and were perpendicular to the axis, which was then straight.

The outer layer of fibres  $K_1 J_1$  will be extended by the bending moment, whilst the inner layer of fibres  $K_2 J_2$  will be compressed. One layer of fibres between these two extremes will be neither extended nor compressed, it will be unaltered in length. Let  $K_0 H_0 J_0$  be this layer.  $O$ , the centre of curvature of the element, will lie on the intersection of the two planes  $K_1 K_0 K_2$  and  $J_1 J_0 J_2$ .  $OH_0 = R$  will be the radius of curvature of the layer  $K_0 H_0 J_0$ . Let the angle  $K_0 O J_0$  be  $\delta\theta$ .

Consider a layer of fibres  $K H J$  distant  $v$  from the layer  $K_0 H_0 J_0$ . The original length of this layer was the same as that of the layer  $K_0 H_0 J_0$  and the latter is unaltered in length by the bending moment. Therefore, the original length of both layers  $K_0 H_0 J_0$  and  $K H J$  was  $R \cdot \delta\theta$ . The strained length of the layer  $K H J$  is  $(R + v) \delta\theta$ . Hence the alteration in length of this layer is  $(R + v) \delta\theta -$

$R \cdot \delta\theta = v \cdot \delta\theta$  and the strain in it is

$$\frac{\text{alteration in length}}{\text{original length}} = \frac{v \cdot \delta\theta}{R \cdot \delta\theta} = \frac{v}{R}$$

If  $E$ , the modulus of elasticity of the material, be assumed constant, and  $f$  be the stress in the layer, then

$$f = E \times \text{strain} = E \cdot \frac{v}{R}; \text{ or } f = E \frac{v}{R} \quad \text{-----(7)}$$

Since  $\frac{E}{R}$  is constant for the element under consideration,  $f$  varies as  $v$ ; that is to say, the stress in any layer of fibres varies directly as the distance of that

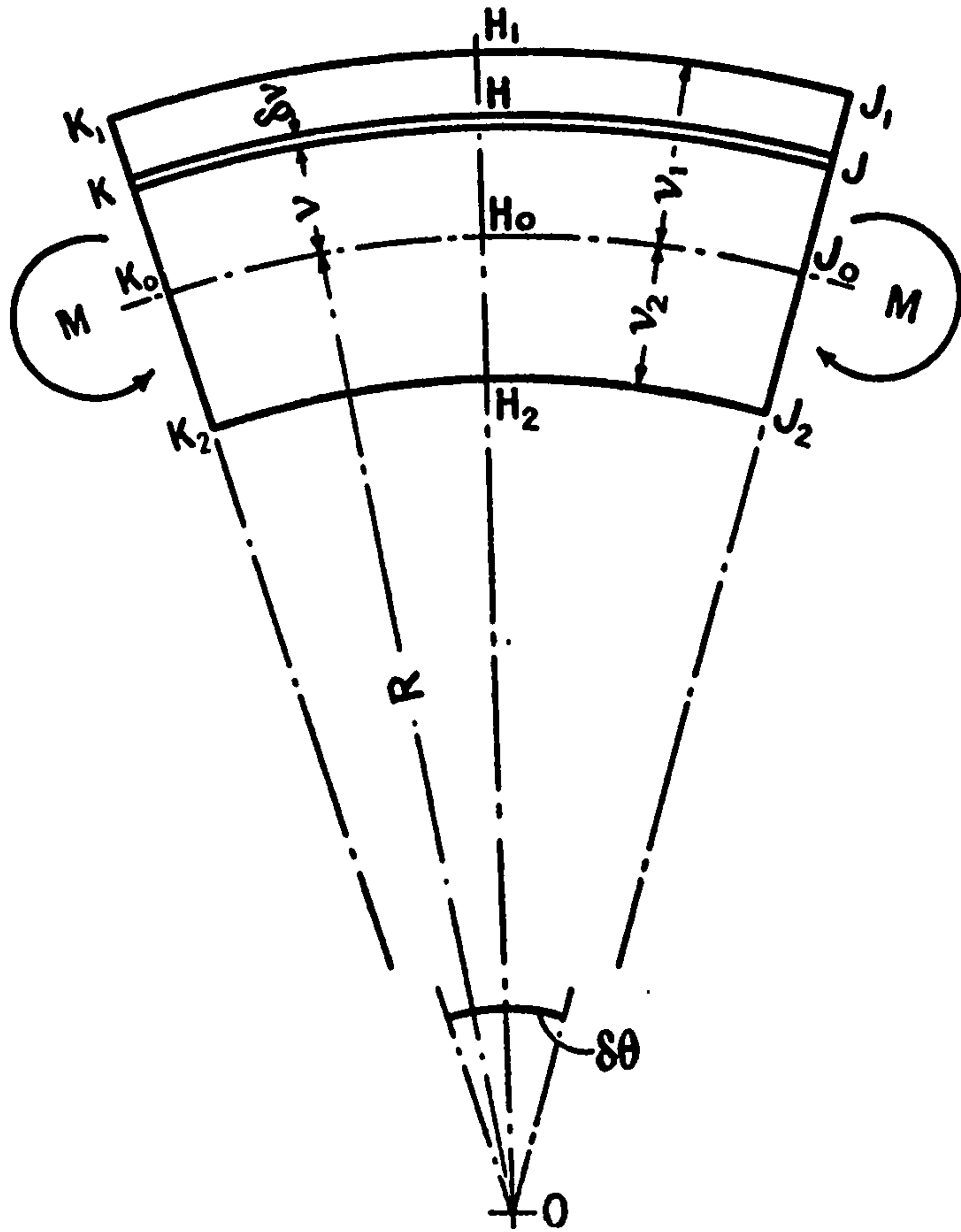

Figure 4-13  
Stress on a Cross-section; Uniplanar Bending.

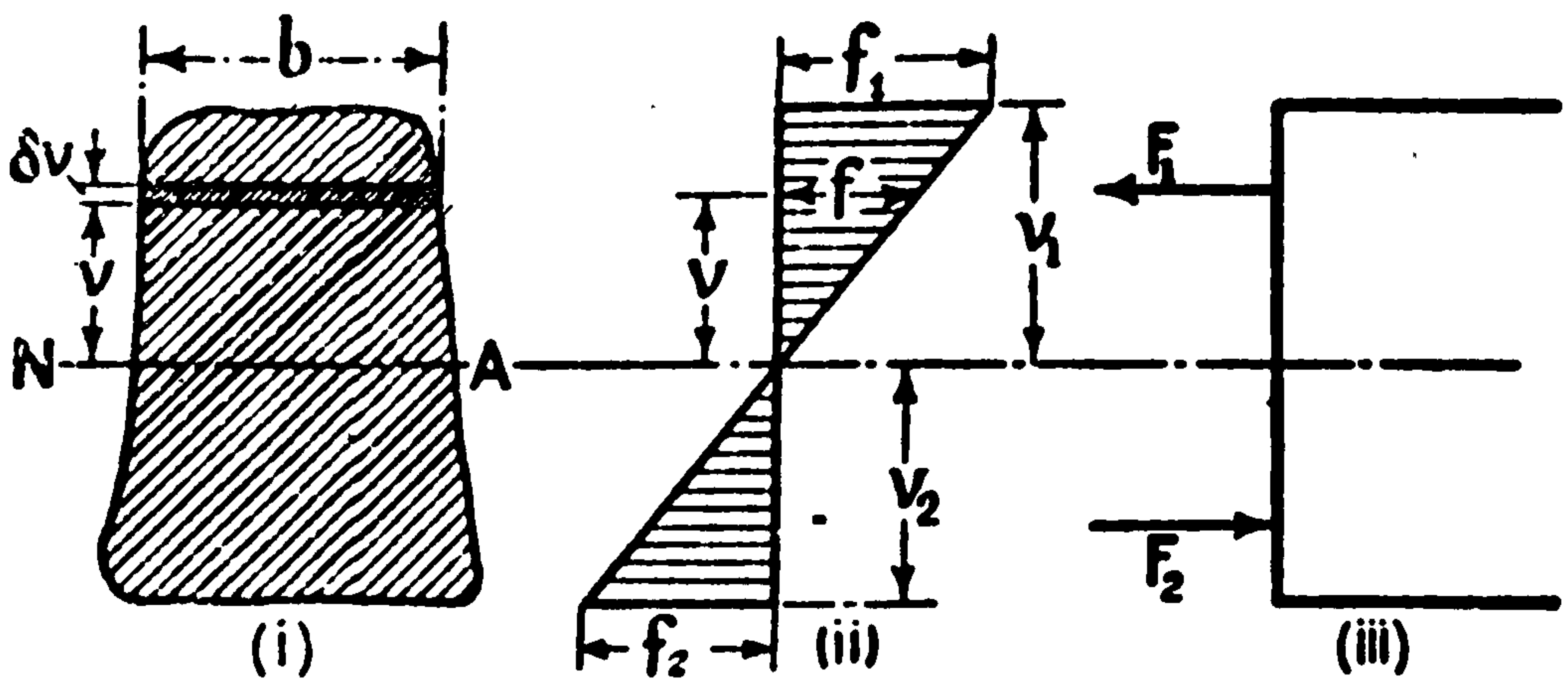

Figure 4-14  
Variation in Stress due to Bending.

layer from the layer unaltered in length by the bending moment. The diagram (ii Figure 4.14) representing the variation in stress, is a straight line. At the layer Jo Ho Ko (Figure 4.13),  $v = 0$ ; and the stress is zero. This layer of fibres is called the neutral surface, and its intersection with the plane of bending is called the neutral line. The line N A (i Figure 4.14.), which represents the section of the neutral surface by any right transverse cross section, is called the neutral axis. For layers of fibres above the neutral surface  $v$  is positive, and if, as in Figure 4.13 the bending moment is positive, the stress is tensile (positive). For layers of fibres below the neutral surface  $v$  is negative, and the stress is compressive (negative). This is clearly shown by the double triangle of (ii Figure 4.14) which represents the variation of stress over the cross section. The maximum tensile stress  $f_1$  will occur in the extreme layer of fibres,  $v = v_1$ , on the extended side of the beam.

From equation 7

$$f_1 = \frac{E v_1}{R} \quad \text{----- (8)}$$

Similarly, the maximum compressive stress  $f_2$  will occur in the extreme layer of fibres in compression,  $v = -v_2$ , its magnitude is

$$f_2 = -\frac{E v_2}{R} \quad \text{----- (9)}$$

the negative sign denoting compression.

#### 4.3.2. Position of Neutral Axis

Let  $b$  (i, Figure 4.14) be the breadth of the layer of fibres distant  $v$  from the neutral axis. If  $\delta v$  be the thickness of the layer, its area is  $b \cdot \delta v$ . The force on this layer is  $f b \cdot \delta v$ ; where  $f$  is the stress therein. Hence the total force  $F_1$  (iii Figure 4.14.) on that part of the cross-section above the neutral axis is

$$F_1 = \int_0^{v_1} f b \cdot d v = \frac{E}{R} \int_0^{v_1} b v \cdot d v \quad \text{----- (10)}$$

Similarly, the total force on that part of the cross-section which is

below the neutral axis is

$$F_2 = \int_0^{-v_2} f b \cdot d v = \frac{E}{R} \int_0^{-v_2} b v \cdot d v \quad \text{----- (11)}$$

The total longitudinal force on the cross-section of the beam will be  $F_1 + F_2$ , but since these forces are produced by a bending moment only, and no longitudinal force exists, it follows that

$$F_1 + F_2 = 0; \text{ or } F_1 = -F_2 \quad \text{-----(12)}$$

and that

$$F_1 + F_2 = \frac{E}{R} \int_0^{v_1} b v \cdot d v + \frac{E}{R} \int_0^{-v_2} b v \cdot d v = \frac{E}{R} \int_{-v_2}^{v_1} b v \cdot d v = 0$$

from which  $\int_{-v_2}^{v_1} b v \cdot d v = 0 \quad \text{-----(13)}$

But  $\int_{-v_2}^{v_1} b v \cdot d v = a \bar{v}$ , where  $a$  is the area of the cross-section, and  $\bar{v}$  is the distance of its centre of area from the neutral axis. Hence from equation (13)  $a \bar{v} = 0$ ,  $\bar{v} = 0$ . That is to say, the neutral axis passes through the centre of area of the cross section. Since the bending is uniplanar, the neutral axis will be perpendicular to the plane of bending.

#### 4.3.3. The moment of Resistance

The bending moment upon the element will be resisted by an equal and opposite moment of the internal stresses set up in the beam. This moment of the internal stresses is called the moment of resistance. It is evidently the moment of the resultant tensile and compressive forces  $F_1$  and  $F_2$  (iii Figure 4.14) which act on the cross-section. These have been shown to be equal (Equation 12). Therefore, they form a couple, and moments may be taken about any point. Take moments about the neutral axis.

The force on a layer of fibres distant  $v$  from the neutral axis has been

shown to be

$$f \cdot b \cdot \delta v = \frac{E}{R} b v \cdot \delta v. \text{ The moment of this force about the neutral}$$

axis is

$f \cdot b \cdot v \cdot \delta v = \frac{E}{R} b v^2 \cdot \delta v.$  Hence the total amount of all such forces on the cross section, which is the moment of resistance is

$$\frac{E}{R} \int_{-v_2}^{v_1} b v^2 \cdot d v \text{ But } \int_{-v_2}^{v_1} b v^2 \cdot d v = I, \text{ where}$$

$I$  is the moment of inertia of the cross-section about an axis through its own centre of area perpendicular to the plane of bending, i.e., about the neutral axis.

Hence the moment of resistance, which is equal to the bending moment  $M$ , is  $\frac{E I}{R} = M$ ; and it follows from equation (7) that

$$\frac{M}{I} = \frac{E}{R} = \frac{f}{v} \text{ -----(14)}$$

and  $f = \frac{M v}{I}$  -----(15)

At the extreme fibres in tension  $f = f_1$  and  $v = v_1$ .

Therefore  $f_1 = \frac{M v_1}{I}$  -----(16)

Similarly, at the extreme fibres in compression

$$f = f_2 \text{ and } v = -v_2$$

Therefore  $f_2 = -\frac{M v_2}{I}$  -----(17)

Now  $\frac{1}{v_1}$  and  $\frac{1}{v_2}$  are called the moduli of resistance or section moduli of the cross-section and are represented by the letter  $Z_1$  and  $Z_2$  respectively.

Hence,  $M = f_1 Z_1 = F_2 Z_2$  -----(18)

From these equations the stresses in a beam due to bending can be determined.

The foregoing is usually referred to as the Theory of Simple Bending. A number of assumptions have been made or implied and the theory is only approximate. Nevertheless as proved by practice and experiment, it is sufficiently accurate for ordinary engineering problems and may with confidence be applied to them. A more exact theory taking into account the shear stresses, has been given by Saint-Venant, and will be found in treatises on the Theory of Elasticity (73).

4.3.4. The Moment of Inertia. The moment of inertia of the cross-section about a principal axis through the centre of area is given by the integral,

$$I = \int_{-v_2}^{v_1} b v^2 \cdot d v \quad (\text{see 4.3.3.})$$

For simple cross-sections this integral can be evaluated directly (Salmon) (68). In more complicated cases direct integration may not be convenient or even possible.

4.3.5. Calculation of Bending Stresses in a Beam.

Given a beam loaded in any specified manner, to find the maximum bending stresses on any cross-section. From the given load system, find  $M$  the bending moment at the cross-section. Calculate the values of the section moduli  $Z_1$  and  $Z_2$  from the dimensions of the cross-section. Then from Equation 18, the stresses at the extreme fibres of the cross-section are

$$f_1 = \frac{M}{Z_1} ; \quad f_2 = \frac{M}{Z_2} \quad \text{or}$$

Alternatively from equations 16 and 17

$$f_1 = \frac{M v_1}{I} \quad \text{and} \quad f_2 = \frac{M v_2}{I}$$

One of these will be the maximum bending stresses on the cross-section.

4.3.6. Bending Moment of a Cantilever. (Salmon) (37).

A cantilever, length  $L$ , loaded with concentrated load  $W$  at its free end. The shearing force and bending moment diagrams for this case are given in (ii)

and (iii) Figure 4.16. At any section K, distant  $x$  from A, the shearing force is equal to  $W$ . Hence the shearing force diagram is a rectangle  $a b c d$ . The bending moment  $M_K$  at K is  $Wx$ . Hence the bending moment diagram is a triangle  $a^1 b^1 c^1$ , the ordinate at  $a^1$ , where  $x = 0$ , is zero, and at  $b^1$ , where  $x = L$  is  $W L$ . This is the maximum bending moment on the cantilever. The vertical reaction at the wall is equal to  $W$ , and the wall must also be capable of resisting the bending moment  $W.L$ .

#### 4.4. Deflection of Beams, (Salmon)(68).

Curvature. Let J K H (Figure 4.15) be part of the deflection curve of a beam, and K and H any two neighbouring points on that curve. Let the co-ordinates of K be  $x$  and  $y$ , and those of H be  $(x + \delta x)$ ,  $(y + \delta y)$ . The ordinate  $y$  is the deflection of the beam from the straight line  $O x$  at a point distant  $x$  from the origin  $O$ . Draw  $K T_1$   $H T_2$  tangents to the curve at K and H respectively, and produce  $T_1 K$  to meet  $T_2 H$  in  $Q$ . Let the angle  $K T_1 x$  be  $\theta$ , and  $H T_2 x$  be  $(\theta + \delta\theta)$ . Then the angle  $H T_2 x$  is equal to the angle  $K T_1 x$  plus the angle  $T_1 Q T_2$ . Hence the angle  $T_1 Q T_2 = \delta\theta$ . Draw  $K C$  and  $H C$  perpendicular to  $K T_1$  and  $H T_2$  respectively; the angle  $K C H$  is equal to  $\delta\theta$ .

$$\text{Let } K H = \delta s. \text{ Then if } C K = R, \delta\theta = \frac{K H}{C K} = \frac{\delta s}{R}, \text{ and } \frac{1}{R} = \frac{\delta\theta}{\delta s}.$$

In the limit, when  $\delta\theta$  is very small, K and H become consecutive points, R becomes the radius of curvature at K, and

$$\frac{1}{R} = \frac{d\theta}{ds} \quad \text{-----(19)}$$

Now  $\tan \theta = \frac{dy}{dx}$  Differentiate with respect to  $s$ ,

$$\sec^2 \theta \cdot \frac{d\theta}{ds} = \frac{d^2 y}{dx^2} \cdot \frac{dx}{ds}.$$

In the limit, when  $\delta x$  is very small,

$$\frac{\delta x}{\delta s} \text{ becomes } \frac{dx}{ds} = \cos \theta \text{ (ii Figure 4.15)}$$

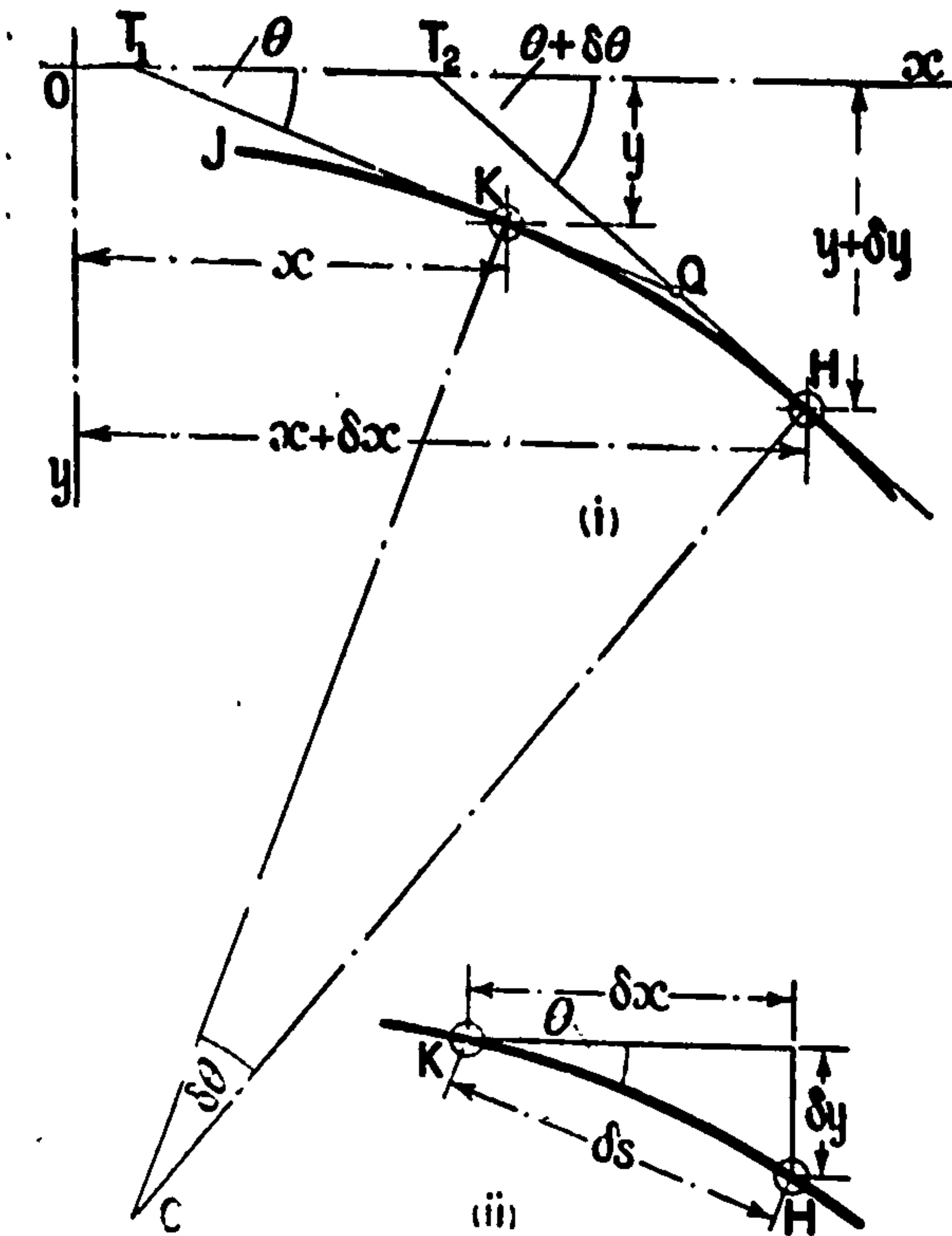

Figure 4-15 Deflection of Beams - Curvature.

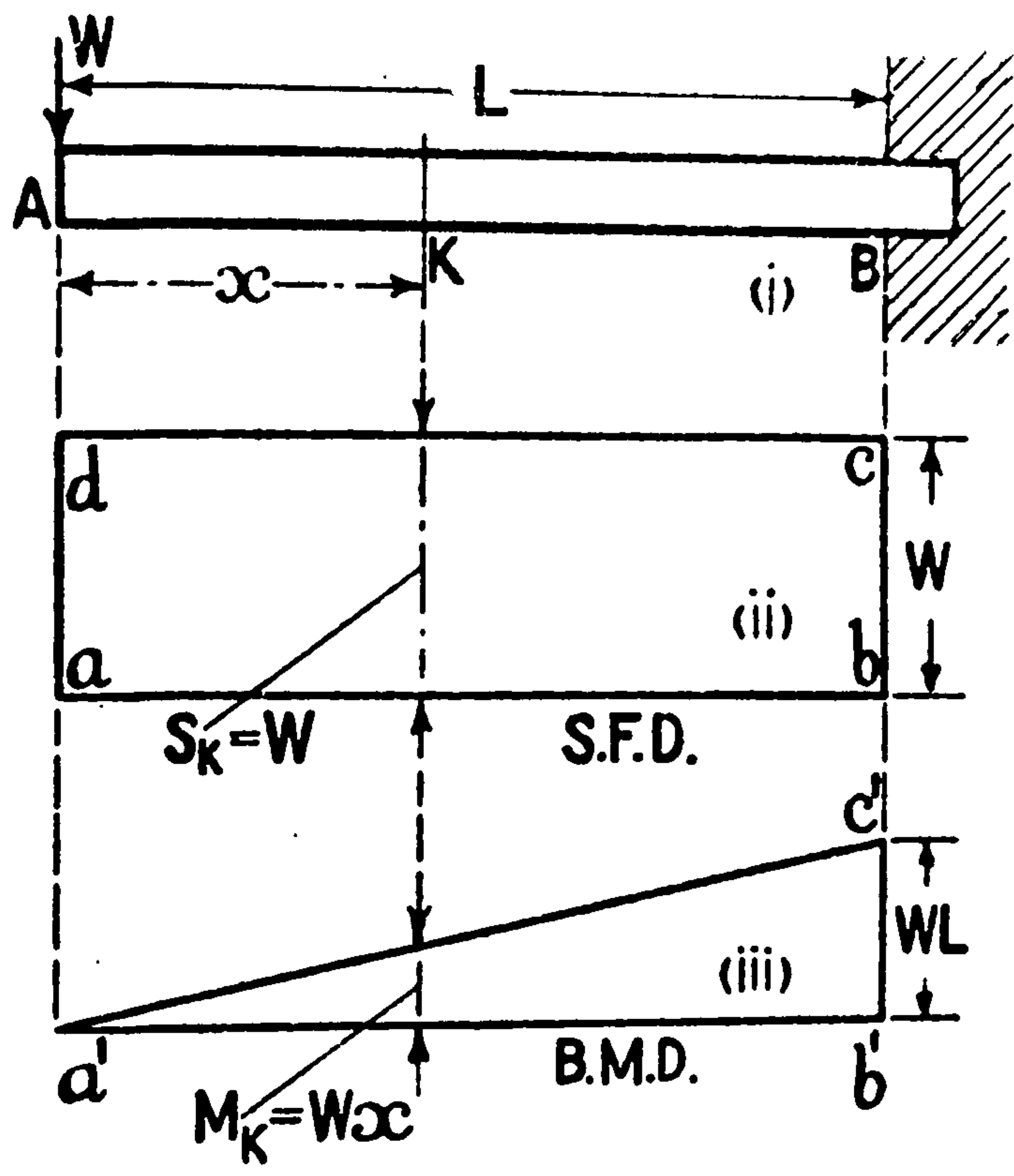

Figure 4-16 Bending Moment and Shearing Force Diagrams of a Cantilever Spring.

Hence

$$\frac{d\theta}{ds} = \frac{d^2 y}{dx^2} \cdot \frac{1}{\sec^3 \theta} = \frac{d^2 y}{dx^2} \cdot \frac{1}{(1 + \tan^2 \theta)^{\frac{3}{2}}} \quad \text{or from eq. 19}$$

$$\frac{d\theta}{ds} = \frac{1}{R} = \frac{\frac{d^2 y}{dx^2}}{\left\{ 1 + \left( \frac{dy}{dx} \right)^2 \right\}^{\frac{3}{2}}} \quad \text{-----(20)}$$

$1/R$  is usually called the "curvature of the beam" at the point K. Equation 20 is the ordinary expression for the curvature in terms of the co-ordinates of the curve. In a beam, the curvature is always very small, and  $\theta$  is a very small angle. Therefore  $\tan \theta = \frac{dy}{dx}$  is very small, and  $\left( \frac{dy}{dx} \right)^2$  can be neglected in comparison with unity.

Equation 20 then reduces to

$$\frac{1}{R} = \frac{d^2 y}{dx^2} = \frac{M}{EI} = \frac{f}{E v} \quad \text{-----(21)}$$

since, from equation 14,

$$\frac{M}{I} = \frac{E}{R} = \frac{f}{v}$$

The deflection of the beam can be found by solving the differential equation (21).

#### 4.4.1. Deflection of Cantilever Beam. (Salmon)(68).

In the following case it will be assumed that both E and I are constant.

Consider a uniform cantilever, span L loaded with concentrated load W at the free end (Figure 4.17). Let A be the origin, and consider any section K distant x from A. Let y be the deflection there. The bending moment at K is  $M = W(L-x)$

From equation 21

$$\frac{d^2 y}{dx^2} = \frac{M}{EI} = \frac{W}{EI} (L-x)$$

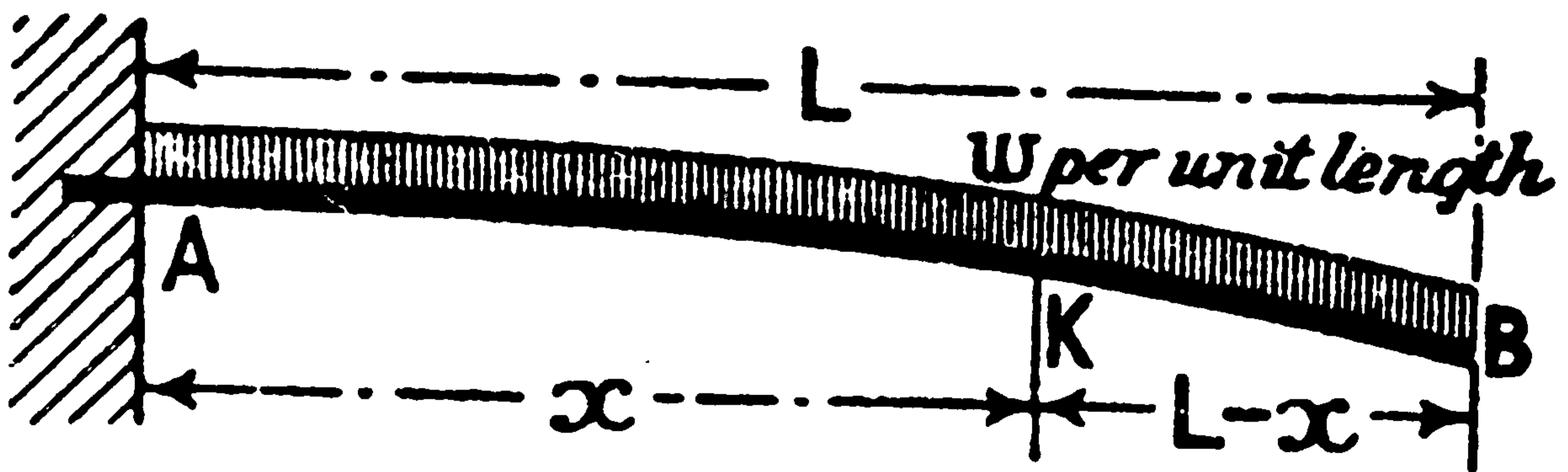

Figure 4.17 Deflection of a Cantilever Spring.

integrating this  $E I$  being constant

$$\frac{d y}{d x} = \frac{W}{E I} \left\{ L x - \frac{x^2}{2} \right\} + c_1 \quad \text{----- (22)}$$

At the origin, where  $x = 0$ , the beam is horizontal, hence  $\frac{d y}{d x} = 0$ , and  $c_1 = 0$ . From equation 22 the slope of the beam everywhere can be obtained.

Integrate again

$$y = \frac{W}{E I} \left( \frac{L x^2}{2} - \frac{x^3}{6} \right) + c_2$$

At the origin, where  $x = 0$ , the deflection  $y = 0$ , and hence  $c_2 = 0$

$$\text{Therefore } y = \frac{W}{E I} \left( \frac{L x^2}{2} - \frac{x^3}{6} \right) \quad \text{----- (23)}$$

This equation gives the deflection at any section  $K$ . The maximum deflection occurs at  $B$ , where  $x = L$

$$\text{max. } y = \frac{W L^3}{3 E I} \quad \text{----- (24)}$$

## Chapter 5

### 5. TYPES OF TESTS

#### 5.1. Previous Work

Both tensile and bend tests have been used by previous investigators to determine the properties of wire.

Angell 1950 (8) reported that "tensile and bending tests do not show concordant properties on the same material".

If tensile properties are analysed in determining the usefulness of materials, wrong conclusions will frequently be reached if the materials are to be used in bending.

Angell used bend tests to compare 18-8 stainless steel wire with platinised gold wire for orthodontic arches and springs. He decided that gold would be the better wire due to its greater modulus of resilience, and the fact that it can be heat treated after soldering.

Delgado and Anderson 1963 (33) carried out tensile and bend tests on stainless steel wires (1.0 mm. to .025 mm) available in the United Kingdom.

They gave comparative figures for proportional limit, ultimate tensile strength, and number of reverse bends. Also they discussed the percentage of proportional limit to ultimate tensile strength.

Newman 1963 (56) carried out tensile tests on .016 inch diameter Australian wire, 18.8 American Stainless Steel Wire (302), unbalanced semi austenitic stainless steel wire, and cobalt chromium nickel wire.

He found that the stress relieved unbalanced semi austenitic stainless steel wire, showed the best tensile properties, Australian and heat treated cobalt chromium nickel were about the same, and 18.8 stainless steel had the worst.

Craig et al 1965 (32) carried out tensile and bend tests on .014 inch and .022 inch wires of 17.7 precipitation hardenable stainless steel, 18.8 stainless

steel and cobalt-chromium-nickel wires.

He found that the properties of the cold worked 17.7 PH steel and the other two were comparable (Unitek & Tru Chrome S.S. and spring temper cobalt chrome nickel (Elgiloy) although the yield strength in tension of the 17.7 PH was superior to the other two.

After heat treatment of the 17.7 PH stainless steel the strength properties increased greatly. This was however accompanied by a decrease in ductility.

PH used above and in following pages indicates precipitation hardening.

Mahler & Goodman 1967 (50) compared the elastic deformation-force ratio and elastic force limits of .018" diameter stainless steel wires and cobalt chromium nickel wires (elgiloy).

They concluded that all wires produced elastic force limits in excess of that required for light wire applications. Heat treatment increased the elastic force limit appreciably in most cases, but decreased slightly the elastic deformation-force ratio.

Howe et al 1968 (44) carried out tensile tests to compare the effects of stress relief on types 302 and 316 (.022 inch diameter) austenitic stainless steel wires.

They concluded that type 316 material exhibited superior elastic properties to 302, but both types needed a stress relief anneal to give maximum stiffness and resistance to deformation.

#### 5.1.1. Tensile Tests

The strength of wires used for arch-wires is usually determined by tensile testing as for most metallic materials.

The entire length of wire is subjected to tensile stresses, and the stress strain relationship can be established as described (4.1.5.)

The stress-strain curve shows:-

- (a) The proof load (4.1.9.)
- (b) The ultimate tensile strength (4.1.10.).

Proof Stress (Eq. 2.) and the Modulus of Elasticity (Eq. 3.) can be calculated.

The Australian Standard T 32 dealing with Resilient Orthodontic Wires classifies wires into four types, A.B.C.D., based on the ultimate tensile strength. The Standard indicates that the very high tensile type D wire is required principally by Orthodontists using the Begg technique.

### 5.1.2. Bend Tests

The strength of wires used as arch-wires can also be obtained from Bend Tests.

The load-deflection relationship can be established with a curve very similar to that obtained from tensile testing.

The Proof Load in bending can be determined.

Proof Stress can be calculated

$$(4.3.5.) \quad f = \frac{M v}{I}$$

Section modulus for circular section in bending

$$\frac{I}{v} = \frac{\pi d^3}{32}$$

$$\text{Proof stress for circular section} = \frac{p \times l \times 32}{d^3} \quad (\text{Braddick})(21)$$

where:-

p = load at proportional limit

l = length

d = diameter

The deflection can be measured.

The modulus of elasticity can be calculated

$$(Eq.24.) \quad \text{Max. } y = \frac{W L^3}{3 E I}$$

(Actually Bend Tests were carried out on a Tinius Olsen Stiffness Testing Machine, and the modulus of elasticity in bending was calculated from the Tinius Olsen Formula for Round Materials, which is simply a modification of the above.

### Flat Materials

$$E = \frac{4 S}{W d^3} \times \frac{M \times \text{Scale Reading}}{100 \phi}$$

### Round Materials

$$E = \frac{S}{.1473 d^4} \times \frac{M \times \text{Scale Reading}}{100 \phi}$$

where

E = modulus of elasticity in bending

W = width in inches

S = span inches

d = diameter or thickness of specimen in inches

M = moment weight on pendulum

$\phi$  = angular deflection in radians (Straight section of curve))

Function of an orthodontic archwire is dependent on elastic deformation. Elastic loading of the structure occurs when the archwire is pinned into the brackets, and unloading occurs when the archwire returns to its original form.

Under these conditions bending stresses are induced in the round archwire. Consequently simulated use tests would be more representative. A cantilever is a simple and representative structure, and is used to compare the bend properties of wires.

The work of Angell (8), Bush, Taylor and Peyton (30), Peyton and Moore (58), Brockhurst (22), and myself, indicate that values for proof stress and modulus of elasticity obtained in tensile tests, differ from those obtained in bend tests (also chapters 9. 10.)

It seems more appropriate to compare the strength of wires by means of bend tests rather than tensile tests.

## 5.2. Elastic Strength of Structure.

Structural strength may be defined as the maximum load, of a given character, which the structure can carry (Brumfield)(26).

The elastic strength of the structure (archwire) would be the greatest load which the structure can support without permanent distortion. In bending, the strength would be limited to that load which would induce the proportional limit stress at any point within the structure.

In comparing two structures identical in form but of different materials, the influence of the form of the structures would cancel for purposes of comparison, and the elastic strengths would then vary directly as the proportional limits of the material (Brumfield)(26).

For structures loaded in bending the following relationship may be stated for a circular section: (Brumfield) (27).

$$P = K \cdot S_p \times d^3$$

P represents the load of any given character which the structure may safely carry in bending, and is, therefore its strength.

$S_p$  is the proportional limit

d is depth of the structure in the plane of bending

k is a constant which depends on the kind of loading, the general character of the structure and the method of supporting it.

In order to obtain a structure of greatest strength the Orthodontist must:-

Select the wire with the highest proportional limit (from the .016" stainless steel wires available for Begg Treatment) and if necessary heat treat hard drawn wire, as sub-recrystallisation heat treatment of hard drawn wire increases the proportional limit (Backofen and Gales)(12), (Burstone)(28), (Funk)(39), (Ingerslev)(45), (Howe et al) (44), (Kemler)(48), (Mutchler)(54), (Wilkinson)(80), (also Chapter 6).

Further increase in strength can be obtained by thickening the structure. This would mean using a larger diameter wire. The strength of a wire changes as the third power of the diameter. That is to say if the diameter of the archwire were doubled it could withstand eight times the loading.

### 5.3. Flexibility of Structure

The flexibility of structure (often mistakenly called resiliency) is the amount of distortion, of any given character, which the structure undergoes when a load

within its elastic strength is applied to it (Brumfield)(26). The term is usually reserved for distortions due to bending.

The two properties of materials which are pertinent to the flexibility of all structures are Proportional Limit and Modulus of Elasticity.

"The higher the proportional limit the greater the flexibility under given conditions. Inversely, the higher the modulus of elasticity the less the flexibility, other conditions being constant." (Brumfield)(26).

#### 5.4. Load/Deflection Rate

The relationship of applied force to wire deflection is defined by Hooke's law, which states that within the proportional limit of any material, deflection is proportional to load. Hence throughout the range of activation of a spring, the quotient of applied force divided by deflection is a constant. This constant is termed the Spring constant, Spring gradient, or load/deflection rate. It represents the load necessary to produce unit deflection. (Burstone) (28).

This means that if an archwire A had a load deflection rate of 60 gm./unit deflection, and was deflected 5 units it would be applying a force of 300 gms. During unloading it would drop 60 gms. for each unit.

If another archwire B, had a load deflection rate of 100 gm./unit deflection, and was deflected 5 units it would be applying a force of 500 gms. During unloading it would drop 100 gms. for each unit.

.. Springs that have lower load deflection rates, deliver more constant forces during unloading, since there is less force change from one unit of activation to the next (Burstone)(28).

Therefore, archwire A provides the more constant force of the two and would be demonstrated graphically by a flatter slope of the plotted line (Burstone) (28).

Also the higher the proof load of the archwire the greater the range of activation. That is the greater the deflection without permanent set. Archwires that possess high proof loads and low load deflection rates have high ranges of

activation (Burstone) (28).

Haack (43) designated the ratio of force to deformation as the "stiffness".

From equation 21

$$\frac{d^2 y}{d x^2} = \frac{M}{E I}$$

and

$$M \propto W \cdot L.$$

Then 
$$\frac{W}{y} \propto \frac{E I}{L}$$

For any given spring  $\frac{I}{L}$  is a constant therefore  $\frac{W}{y}$  spring rate is directly proportional to the modulus of elasticity.

The orthodontist is restricted in his power to change the spring rate.

Burstone (28) says that residual stresses induced during cold working modify the stress-strain relationship to a non-linear form and may be responsible for a slight reduction in spring rate. Following stress-relief below the critical temperature the gradient is raised. So that sub-crystallisation heat treatment by the orthodontist could raise the rate slightly.

Otherwise the spring rate can only be changed by changing the material or varying the thickness of the wire. (If space permits rate can be influenced by increase in length or inclusion of helixes).

Should the thickness of the archwire be changed, the spring rate changes as the fourth power of the diameter. The resistance of an archwire to bending, and hence its rate, is determined by distribution of material around the neutral axis (4.4. deflection of beams).

Thus it must be kept in mind that if a structure is thickened to increase strength, the spring rate is also increased. If the thickness of the archwire is doubled the strength is increased eight times but the spring rate is increased sixteen times.

## 5.5 Differential Force

Dr. Begg (18) explains that differential force is made use of in Stage I of his technique. (2.2.)

Bite opening bends in the archwire provide sufficient force to depress the six anterior teeth but insufficient force to appreciably move the anchor molars when supported by intermaxillary elastic traction.

Storey and Smith (71) carried out experiments on the force necessary for bodily distal movement of canines. They found that there is an optimum range of force values, that produces a maximum rate of distal movement of the canines. Their range extended from 150 gms. to 200 gms. If the force increased above this range the rate of movement correspondingly decreased until, at a high force level, there was no movement at all. When the force was increased to 300 gms. appreciable movement was observed in the anchor molars. The optimum force for molars was 300 gms. to 500 gms.

This agrees with the concept that the force necessary to move teeth is proportional to the root area of the tooth. The ratio of canine and molar is approximately 3 : 8.

They found that when a force less than 150 gms. is applied neither the anchor molar nor the canine moved appreciably.

If a force of 300 gms is exerted mesially on a molar, and distally on a canine, the molar moves mesially and the canine remains stationary. This is the exact opposite of what is intended.

Thus to increase the diameter of the wire to improve the strength of the structure, because of the increase in spring rate, could interfere with the rate of movement of teeth, and so treatment time. Also it could cause unintended movement of some teeth and lack of planned movement in other teeth.

## 5.7 Optimal Force

Clinicians generally agree that there are optimal force values for the movement of different teeth, and also for different types of movement of the same teeth (e.g. bodily movement, tipping etc.).

Graber (1961) defines an optimal force as one that moves teeth most rapidly in the desired attitude and direction with the least tissue pathology and the slightest amount of pain.

Storey and Smith (1952) (71) demonstrated the optimal range for bodily movement of canines as 150 gms to 200 gms. For molars it was 300 gms to 500 gms.

Burstone and Groves (1960)(29) retracted anterior teeth by simple tipping and state that optimal rates of tooth movement were observed when 70-75 gms of force were applied.

The association of optimal force values and spring rate are most important.

Once the optimal force, or force range, has been established it is necessary to have low rate springs, which do not rapidly dissipate their stored energy, but move teeth over required distances with one adjustment and within the optimal range. (Burstone) (28)

Sometimes differential and other forces are used reciprocally in the Begg Technique, as with the combined archwire and elastic forces to depress and tip the anteriors distally in Stages I and II. It thus becomes more difficult to allocate optimal force values for each component.

## Chapter 6

### 6. MATERIALS

#### 6.1 Stainless Steel

##### 6.1.1. Discovery

Rust resisting iron-chromium alloys were discovered by Brearley of Sheffield in 1913 (Money Penny)(53).

About the same time Drs. Strauss and Maurer working at the Krupps works in Essen had produced and applied for patents for two chrome-nickel iron alloys. These two men are credited with the discovery of austenitic steel (Gaston 1951) (40).

Paffenbarger (1943)(57) credits the head of the Krupp Dental Clinic as the first to use stainless steel for oral appliances.

DeCoster (35) used stainless steel for orthodontic appliances in Belgium in 1924, but it was not introduced into the Orthodontic Field in the United States until 1929 or 1930 (Gaston) (40)

##### 6.1.2. 18-8 Stainless Steel Wire

Orthodontic wires made from austenitic stainless steel of the 18% chromium 8% nickel composition were found to be the most suitable in the early days. They were commonly referred to as the 18-8 Type (Paffenbarger)(57)

The American Iron and Steel Institute has graded stainless steels, and American Orthodontic wires of the 18-8 type are made mainly from grades 302, 304 and 316.

These wires have been extensively tested from time to time for properties.

The composition of grade 302 and 304 are listed in Table 6.1. These two have almost identical physical properties, the main difference between them being that 304 contains 0.08% carbon maximum, from 18-20% chromium and 8-12% nickel. Grade 316 differs from 302 and 304 in containing 2% more nickel in addition to 2% molybdenum. The addition of molybdenum endows grade 316 with increased corrosion resistance (Howe et al 1964)(44).

In England stainless steel is also covered by Standards. The 18-8 Wilcock wire, is drawn from wire covered by the composition of En 58 A stainless steel, as specified in British Standard 2056 (Table 6.1).

### 6.1.3. Production of Stainless Steel Wire

High tensile strength and high proportional limit can be induced in these austenitic stainless steels by cold working (drawing).

The manufacturer makes his wires from a fine grained metal, as the finer the grain before cold working the greater the mechanical properties.

The wire is first rolled then drawn down to the required dimensions.

The wire becomes hard during this process of cold working and has to be softened before it can be shaped some more.

Before drawing, the crystals are more or less equiaxed, but with drawing they become elongated in the direction of drawing, and the metal becomes harder, stronger and less ductile. When the wire is softened or annealed recrystallisation takes place and the metal reverts to its equiaxed crystalline form. The wire also loses its increased hardness strength and reduction of ductility.

Thus in the final draw the manufacturer work hardens the wire a certain percentage of the fully work hardened condition. The type of metal plus the percentage of work hardening is mainly responsible for the performance of the wire. Low temperature heat treatment does improve the performance a certain amount as will be discussed later.

The effect of cold work is particularly marked in the case of yield stress, which is increased more rapidly than the other strength properties. Severe work hardening can raise the yield stress until it almost coincides with the ultimate tensile stress (Earnshaw)(37).

Wire in this state would be very brittle and not capable of much further deformation. Plier manipulation in the forming of archwire would be very limited.

### 6.1.4. Heat Treatment

After the wire has been drawn it is left with elastic stresses locked in the metal.

Table 6.1

## PRINCIPAL ALLOYING ELEMENTS IN ALLOYS (Weight %)

| Stainless Steel                                | C.           | Cr.   | Ni.             | Co. | Fe.  | Mn. | Si. | Others  |
|--|--------------|-------|-----------------|-----|------|-----|-----|---|
| A.I.S.I. Grade 302                             | 0.15<br>max. | 17-19 | 8-10            |     | Bal. | 2   | 1   | S .03 max.<br>P .04 max.                        |
| A.I.S.I. Grade 304                             | 0.08         | 18-20 | 8-12            |     | Bal. | 2   | 1   | S .03 max.<br>P .04 max.                        |
| A.I.S.I. Grade 316                             |              |       | 12-14           |     | Bal. | 2   | 1   | S .03 max.<br>P .04 max.<br>Mo. 2               |
| British Standard 2056<br>En 58A (Wilcock Wire) | 0.16<br>max. | 17-20 | 25.0<br>Ni. Cr. |     | Bal. | 2   | .2  | S .045 max.<br>P .045                           |
| Dentaurum S.S.H.                               | 0.07         | 16.5  |                 |     |      |     |     | A16.5   |
| " S.S.S.H.                                     | 0.15         | 16-18 | 7-9             |     |      |     |     |   |
| Unisil   | 0.142        | 15.65 | 4.38            |     | Bal  | 1   | .32 | S .013<br>P .027<br>Mo 2.68<br>Cu .12<br>N .124 |
| Cobalt Chromium                                |              |       |                 |     |      |     |     |   |
| Elgiloy(Red)                                   | 0.15         | 20    | 15              | 40  | Bal. | 2   |     | Mo 7<br>Be .04                                  |

These residual stresses weaken the metal, if they are the same type of stresses as the ones which will be induced by loads applied in service (Earnshaw) (37).

The metal is only capable of a certain load, and the stresses already in the metal then effectively reduce the amount of additional load.

The residual stresses are considered undesirable and are removed after cold work. This can be done by heating the metal to temperatures below the recrystallisation temperature, a process known as recovery or stress relief. The residual stresses may be removed in this way, without reducing the improved strength of the metal that resulted from work hardening (Earnshaw)(37).

The grains remain elongated after stress relief and do not revert to the equiaxed condition of recrystallisation.

In addition to the relief of residual stresses by low temperature heat treatment, the properties of the wire are improved.

In heat treatment experiments with stainless steel wires Funk 1951(39) demonstrated an improvement of 25% in the tensile strength and proportional limit. A temperature of 850°F for 3 minutes gave best results.

Backofen and Gales 1951(12) showed similar improvement in properties with best results at 750°F or 820°F for ten minutes.

An increase in tensile strength proportional limit and modulus of elasticity with low temperature heat treatment (5-15 minutes at 700-800°F) was demonstrated by Kemler 1956(48).

Wilkinson 1960(80), Mutchler 1961(54), Delgado and Anderson 1963(33), Ingerslev 1966(45), Howe et al 1968(44), have all written on the beneficial effects of low temperature heat treatment on Orthodontic stainless steel wires.

Backofen and Gales (12) attributed the increase in strength to stress relief of the work hardened wire.

The increase in hardness and reduction in ductility that accompanies the increase in strength seems inconsistent with just stress relief. Brockhurst(23)

in his experiments with heat treatment of wires showed an increase in hardness, associated with an increase in strength. He suggests that stress relief does occur but that strain ageing takes place at the same time, with consequent increase in strength and decrease in ductility, and this is the main reason for the improvement.

Howe et al (44), in their experiments with 302 and 316 stainless steels, observed that mechanical properties of wire were found to vary considerably in the as-received condition from one batch to another.

Kohl (49) comments that the effectiveness of the heat treatment is determined to a large extent by the composition of the steel. In many cases the exact chemical composition of the wire is not given and the physical properties are not clearly defined by the manufacturer. This, coupled with the quality variation seen in many chrome steel wires, makes the determination of a single heat treatment procedure for all situations virtually impossible.

It would seem that orthodontic wires would be best marketed in the heat treated condition. Failing this, instructions for heat treatment should be included with each batch of wire. For the Orthodontist to have to heat treat his wire in a busy practice presents many problems, the greatest perhaps being the maintaining of an efficient furnace. If the Orthodontist in his heat treatment approaches the lower limits of the annealing range of the steel some degree of softening will occur.

This means a reduction in the physical properties of the wire that were induced by cold working. These properties can only be restored by cold working.

It is interesting to note that although the strength of wire is improved considerably by work hardening and heat treatment the elastic modulus varies very little (Kohl)(49)(Burstone)(28)

#### 6.1.5. 18-8 Experimental Wire

Wilcock wires are drawn from 18-8 austenitic stainless steel wire supplied by Samuel Fox of Sheffield England. The composition is shown in Table 6.1.

The full range of .016 inch (nominal) diameter Wilcock wire was obtained from the University Orthodontic Clinic, Dept. of Preventive Dentistry, Sydney.

Each type of wire on plastic spool was marked as follows:-

- (1) A.J.W. - 316  
Regular  
.016" Stainless steel heat treated arch wire  
25 ft. coil  
Ref. O.RIR
- (2) A.J.W. - 316  
Regular Plus  
.016" SS H/T wire 25 ft. coil  
Ref R. R10
- (3) A.J.W. - 316  
Special  
.016" SS H/T wire 25 ft. coil  
Ref. B O .R.LL
- (4) A.J.W. - 316  
Special Plus  
.016" SS H/T wire 25 ft coil  
Ref. C R O I

These wires known as "Wilcock" wire in Australia, and "Australian Wire" overseas is drawn by

H.H. Wilcock, Whittlesea, Victoria, Australia.

The Commonwealth Bureau of Dental Standards Jan. 1967 graded and certified these wires according to Australian Standard T 32 (Table 6.2.).

The gradings were

|              |        |
|--------------|--------|
| Regular      | Type B |
| Regular Plus | Type B |
| Special      | Type C |
| Special Plus | Type D |

The Begg Orthodontic Theory and Technique (1965) 1st Edition (14) stated that .016" round austenitic stainless steel arch wire made by H.J. Wilcock was the most suitable for the technique.

The Second Edition (Begg and Kessling 1971)919) of the same book recommended the use of A.J. Wilcock Special Plus Wire.

#### 6.1.6 Precipitation Hardenable Stainless Steel Wire

The use of precipitation hardenable stainless steels has developed since

| STRENGTH AND CLASSIFICATION (T32) OF ORTHODONTIC WIRES. |               |                               |   |  |                                       |
|---|---------------|-------------------------------|---|--|---------------------------------------|
| BRAND   | NUMBER TESTED | RANGE OF DIAMETERS IN INCHES. | TENSILE STRENGTH  |  | NUMBER FALLING IN T32 CLASSIFICATIONS |
|   |               |                               | TON f/INCH <sup>2</sup>   | 1000 lb f/INCH <sup>2</sup>                      |                                       |
| ASH   | 8             | 0.016 — 0.032                 | 101 — 145   | 226 — 325  | 8 A                                   |
| ASSAB   | 4             | 0.016 — 0.016                 | 141 — 155   | 316 — 352  | 2 A<br>2 B                            |
| ARMCO   | 5             | 0.015 — 0.030                 | 101 — 126   | 226 — 282  | 1 LOW<br>4 A                          |
| ELCLOY RED  | 4             | 0.016                         | 141 — 145   | 316 — 325  | 4 A                                   |
| BRUNTONS  | 5             | 0.020 — 0.032                 | 101 — 124   | 226 — 278  | 2 LOW<br>3 A                          |
| ROCKY MOUNTAINS TRUCHROME                               | 12            | 0.008 — 0.032                 | 126 — 154   | 282 — 345  | 6 A<br>6 B                            |
| TEMCO   | 9             | 0.010 — 0.031                 | 101 — 156   | 226 — 349  | 8 A<br>1 B                            |
| S.SWC.  | 32            | 0.008 — 0.032                 | 101 — 200   | 226 — 448  | 3 LOW<br>2 D<br>3 C<br>7 A<br>17 B    |
| UNTEK   | 20            | 0.012 — 0.030                 | 100 — 145   | 224 — 325  | 5 LOW<br>15 A                         |
| UNTEK Hi T  | 2             | 0.016                         | 172 — 177   | 385 — 396  | 2 C                                   |
| WILPA   | 3             | 0.016 — 0.024                 | 106 — 131   | 237 — 293  | 1 LOW<br>2 A                          |
| WILCOCK   | 50            | 0.008 — 0.032                 | REGULAR 145-155<br>REGULAR+ 156-165<br>SPECIAL 166-175<br>SPECIAL + 176-185 | 325 — 352<br>353 — 370<br>371 — 391<br>392 — 415 | B<br>B<br>C<br>D                      |

Table 6.2 · Strength and Classification of Resilient Wires of 0.016 inch Diameter.

(Ware, Australian Orthodontic Bulletin Jan. 1967)

1946 (Craig et al) (32).

The Armco selection guide (10) for precipitation hardening stainless steels describes the hardening mechanisms of its steels. The compositions of the steels are balanced to produce hardening by two separate mechanisms.

(1) Transformation - an allotropic transformation of austenite to martensite is effected by a thermal austenite conditioning treatment or by cold working.

(2) Precipitation - the resulting structure is then given a simple aging treatment that hardens by precipitation of intermetallic compounds and simultaneously tempers the martensite.

Armco has developed two basic classes of precipitation hardening stainless steels, martensitic and austenitic.

Martensitic 17.4P H, 15.5 P H, P H 13.8 MO. (the MO is a trade mark of Armco but indicates that the steel contains molybdenum).

In these alloys a martensitic structure forms on cooling from a solution treatment (i.e. 1900°F and cooled to room temperature). The product is usually supplied solution treated.

After fabrication the structure is aged in the 900 to 1150°F temperature range, further strengthening the martensite by precipitation hardening and tempering.

The Armco representative in Australia (11) indicated that in the event of a small diameter wire being required, the wire would be drawn after solution treatment and supplied in condition ready for P.H. treatment after forming the structure.

(b) Semi-austenitic 17.7 P H, P H 15.7 MO. P H 14.8 MO.

This structure in the solution treated form is austenitic. The ductile austenitic structure permits forming by conventional techniques developed for the 18.8 types of stainless steel.

The metal structure is then converted to martensite by ageing at 1400°F for 90 minutes or by cold working the metal 60%. In the case of wire the

beneficial effects of work hardening are obtained as well as the martensite structure.

After fabrication of the structure the precipitation hardening treatment consists of ageing at 900°F for one hour.

Craig et al 1965 (32) in tests on Armco 17.7 P H Stainless steel wires found (a) the yield strength in tension of the martensite cold-worked condition was superior to 18.8 stainless steel and cobalt chromium (Elgiloy red-resilient high spring temper) (b) after precipitation hardening 1 hour at 900°F the strength properties of the 17.7 P H improved markedly.

Coutsouradis et al 1967 (31) in a paper on Precipitation Hardening in high strength stainless steels consider that 17.7 P H, 17.4 P H and 15.7 MO owe their high strength to the precipitation of intermetallic compounds formed due to alloying with aluminium, copper or molybdenum.

#### 6.1.7. Experimental Wire

##### (a) Remanit Dentaureum

Three coils of Remanit Dentaureum .016" (Nominal Diameter) Super Spring Hard and three coils of Remanit Dentaureum .016"(Nominal Diameter) Super Special spring hard wire were supplied free by the agents, Rudolph Gunz and Co. of Sydney.

The metal container was marked :-

Remanit  
0.4 A B Super federhart 30 gr  
Dentaureum

The plastic container was marked :-

Super Special Spring Hard  
Order No. 542040  
O.040 .016"  
m m  
7.5 m 25 ft  
Dentaureum Pforzheim  
W. Germany

The Dentaureum Catalogue (34) indicates that Remanit wires are made

from prime quality stainless steel alloys, diamond drawn with outstanding tensile and yield strength, and high modulus of elasticity. Also the super spring hard is heat treated.

Dentaurum Super Spring Hard Wire is produced by Stahlwerke (Stalworks) Ergste G m b h and Company of West Germany (Masson)(51).

The Stahlwerke Ergste give the composition of the wire Ergste 80 S.G. which is used for drawing as corresponding to German Standard No. 4568. This is a 17.7 P H steel and the Company give only the essentials. Carbon 0.07 per cent, chromium 16.5 per cent, nickel plus aluminium 6.5 per cent. (Rudolph Gunz and Co. Pty. Ltd.) 1972 (62).

The Company also state that the composition is very similar to the "American Armco" 17.7 P H stainless steel.

As far as properties are concerned Ergste say that the elastic limit of the heat treated wire is very close to the ultimate tensile strength. (Rudolph Gunz and Co. Pty. Ltd.) (1972) (62).

Super Special Spring Hard Wire has been available on the Australian market for approximately 6 months.

Dentaurum (62) would indicate only that:-

- (a) The wire was heat treated
- (b) The essential composition was
  - 0.15 percent Carbon
  - 16.0 to 18.0 percent Chromium
  - 7.0 to 9.0 percent Nickel

This information suggests that Remanit Dentaurum Super Special Spring Hard Wire is an 18-8 type wire.

(b) Unisil

Four coils of Unisil wire were supplied free by Unitek Corporation, 950 Royal Oaks Drive, Monrovia, California 91016.

The plastic spools were marked:-

Unisil Light Wire  
.016 25 ft  
354 - 140 (Catalog No)

Preformed .016 archwires were obtained from the University Orthodontic Clinic, Dept. of Preventive Dentistry, Sydney.

The composition of the Unisil Wire (NS - 355 drawn by the National Standard Co) taken from the procurement specification is listed in Table 6.1.

The Unitek catalogue states that the wire achieves 360 000 p.s.i. tensile strength.

Unisil is a precipitation hardening stainless steel, is not stress relieved, but the manufacturers advise against heat treatment without "sophisticated equipment." (76).

## 6.2 Cobalt Chromium

The main Cobalt-Chromium wires used in Orthodontics are those known as Eligoy.

Eligiloy is a Cobalt base alloy which was developed by the Batelle Memorial Institute in conjunction with the Elgin National Watch Coy. The alloy was initially intended for watch springs, but has found application in other fields, not least of which is Orthodontics (Greener and Hillam)(42).

The wire is marketed by Rocky Mountains Dental Products Co. Denver, Colorado.

The typical mechanical properties for Eligiloy Wire (Data)(61) are:-

|                       |                  |
|-----------------------|------------------|
| Ultimate strength     | 340 000 p.s.i.   |
| Yield strength        | 310 000 p.s.i.   |
| Shear Yield           | 210 000 p.s.i.   |
| Modulus of Elasticity | 28500 000 p.s.i. |
| Torsional Modulus     | 11200 000 p.s.i. |
| Hardness (Rockwell C) | 51 -55           |

To obtain best properties the wire is cold reduced and heat treated after forming.

Elgiloy is fabricated in four tempers which are colour identified on the end of each wire. They are :-

RM Blue Elgiloy (soft)

It can be easily bent with the fingers or pliers, and is recommended when the wire to be used is over .020" or when wire requires considerable shaping, welding or soldering.

Should be heat treated for best results.

RM Yellow Elgiloy (ductile)

Initially it is relatively ductile and can be bent with the fingers and pliers. After heat treatment it can be adjusted slightly, but should not be bent or adjusted sharply.

RM Green Elgiloy (semi-resilient)

Can be shaped easily with fingers and pliers before heat treatment. Spring temper is comparable to good spring temper steel wire.

It should not be adjusted sharply after heat treatment.

RM Red Elgiloy (Resilient High Spring Temper)

A hard wire with exceptionally high spring qualities. Only allows minimum work hardening after heat treatment.

Greener and Hillam (42) on the basis of microstructural evidence and the analysis of the physical properties of the wire concluded that, the difference between the four tempers of Elgiloy is in the degree of strain hardening received by each wire in the wire drawing process and not by a variation in the composition of the alloy. Thus the red receives the greatest amount of cold working, blue the least, with green and yellow being cold worked to an intermediate degree.

### 6.2.1 Heat Treatment

Recommended heat treatment Elgiloy 900°F (482°C).

Elgiloy has a tendency to embrittle between 1100°F and 1400°F.

Mutchler 1961 (55) in his investigations into the heat treatment of Elgiloy wire found:-

- (1) Controlled heat treatment produces an increase in the proportional limit, modulus of elasticity and modulus of resilience.

(2) The optimum heat treatment for Elgiloy is 3-15 minutes at temperature 900°F (482°C) to 1000°F (538°C).

(3) Temperatures of 1100°F (593°C) and 1200°F (649°C) produce no harmful effect on the cobalt chromium wire when heated for less than 3 minutes.

Greener and Hillam (42) say that the reaction of the wire to heat treatment can be explained as an age hardening reaction, which may further be divided into precipitation and order hardening.

With heat treatment in the hands of the Orthodontist, care must be taken that over-heating does not occur with either embrittling or annealing.

#### Method of Heat Treatment

The suppliers give the following information on how to heat treat Elgiloy (61)

(1) Electric Resistance Procedures

(a) R.M. Heat treating Unit and tempering paste

(b) R.M. Adapting cables. Place tips three quarters of inch apart. Heat wire to dull cherry colour (do not allow wire to become red hot as this will cause annealing)

(2) Brush Flame

(3) Dental Oven 900°F (482°C) for 7-12 minutes.

#### 6.3 Experimental Wire

Red Elgiloy (Resilient high spring temper) was selected for testing. This wire has had the greatest amount of work hardening (Greener and Hillam)(42).

Elgiloy Orthodontic wire is marketed in 14 inch lengths and the .016" (nominal diameter) Red Elgiloy was obtained from the University Orthodontic Clinic, Department of Preventive Dentistry, Sydney.

In the Strength and Classification (T32) of Orthodontic Wires (Table 6.2) Elgiloy Red was classified as A.

Thus the .016 inch (nominal diameter) wires to be tested consist of 18-8, precipitation hardenable, or cobalt chromium nickel stainless steel.

## Chapter 7

### 7. TENSILE TESTING

#### 7.1. Method

Six samples of each manufacturer's wire or wires were subjected to tensile tests with the exception of Unisil Light Wire (preformed archwire).

All wires were tested in the as-received condition with the exception of Elgiloy, which was heat treated to manufacturers instructions as follows:-

Elgiloy (Red)       $482^{\circ}\text{C} \pm 2^{\circ}\text{C}$  for 10 minutes

There were eight different wires and six samples of each making a total of 48 wires tested.

#### Heat Treatment

The wires (Elgiloy) were placed in the furnace at the required temperature.

Six inch lengths of the test wire were tied with stainless steel ligature wire to a chrome - alumel thermocouple, so that the hot junction of the thermocouple was located at the mid point of the wires.

Each bundle of three wires was placed in the electric tube type furnace (constructed at the Dental Hospital), so that the mid point of the wires was in the hottest zone of the furnace. The temperature variation in the 2 inch hot zone of the furnace was  $2^{\circ}\text{C}$  as indicated by the thermocouple.

After heat treatment the wires were rapidly cooled in air.

#### Hounsfield Tensometer

Tests were conducted with a Hounsfield Tensometer Type W (Fig. 7.1.)

Vee Grip chucks (Fig. 7.2.) were used to test wires received in the heat treated condition. These chucks had been used satisfactorily in previous experiments on .016 inch light wires (Masson)(71). However, the Vee Grip chucks required about 15 inches of wire for satisfactory testing with the extensometers.

Disc Wire chucks (Fig. 7.4.) needing less wire were used in the testing of the 6 inch lengths of experimentally heat treated wire (Elgiloy (Red)).

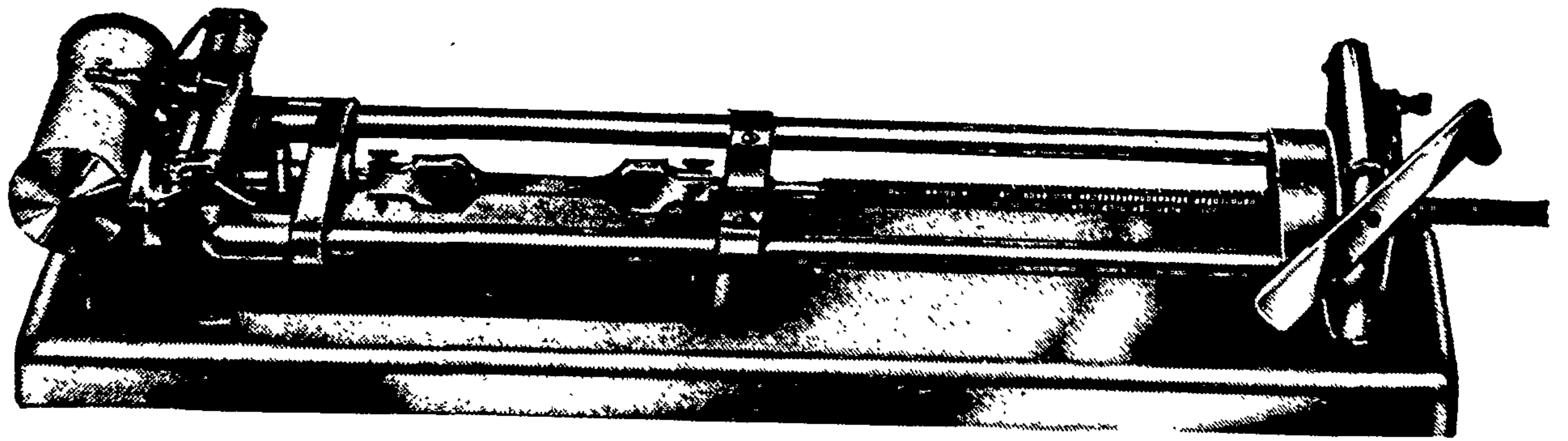

Fig. 7.1 - Hounsfield Tensometer Type W.

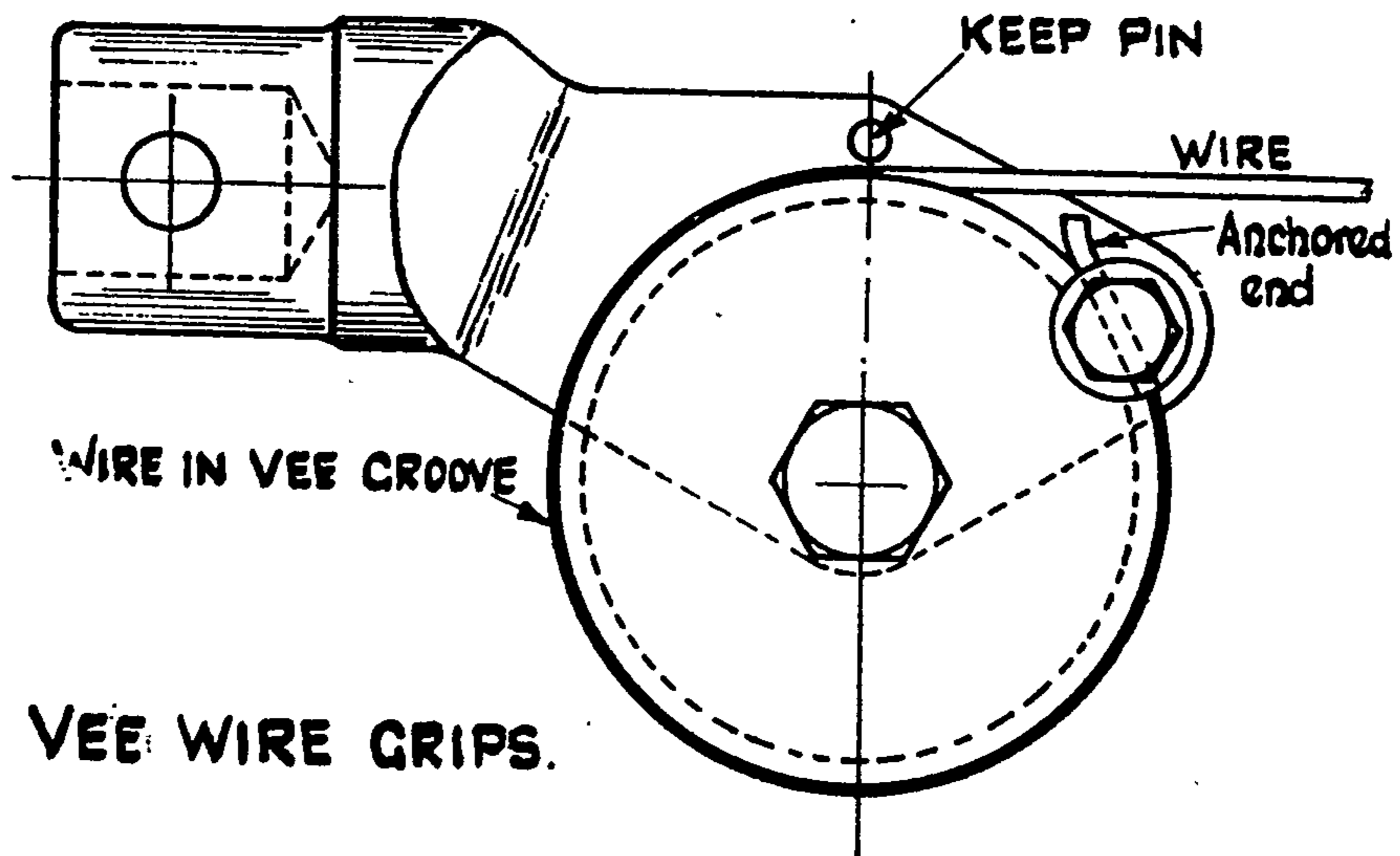

Fig. 7-2 Vee-Wire Grips.

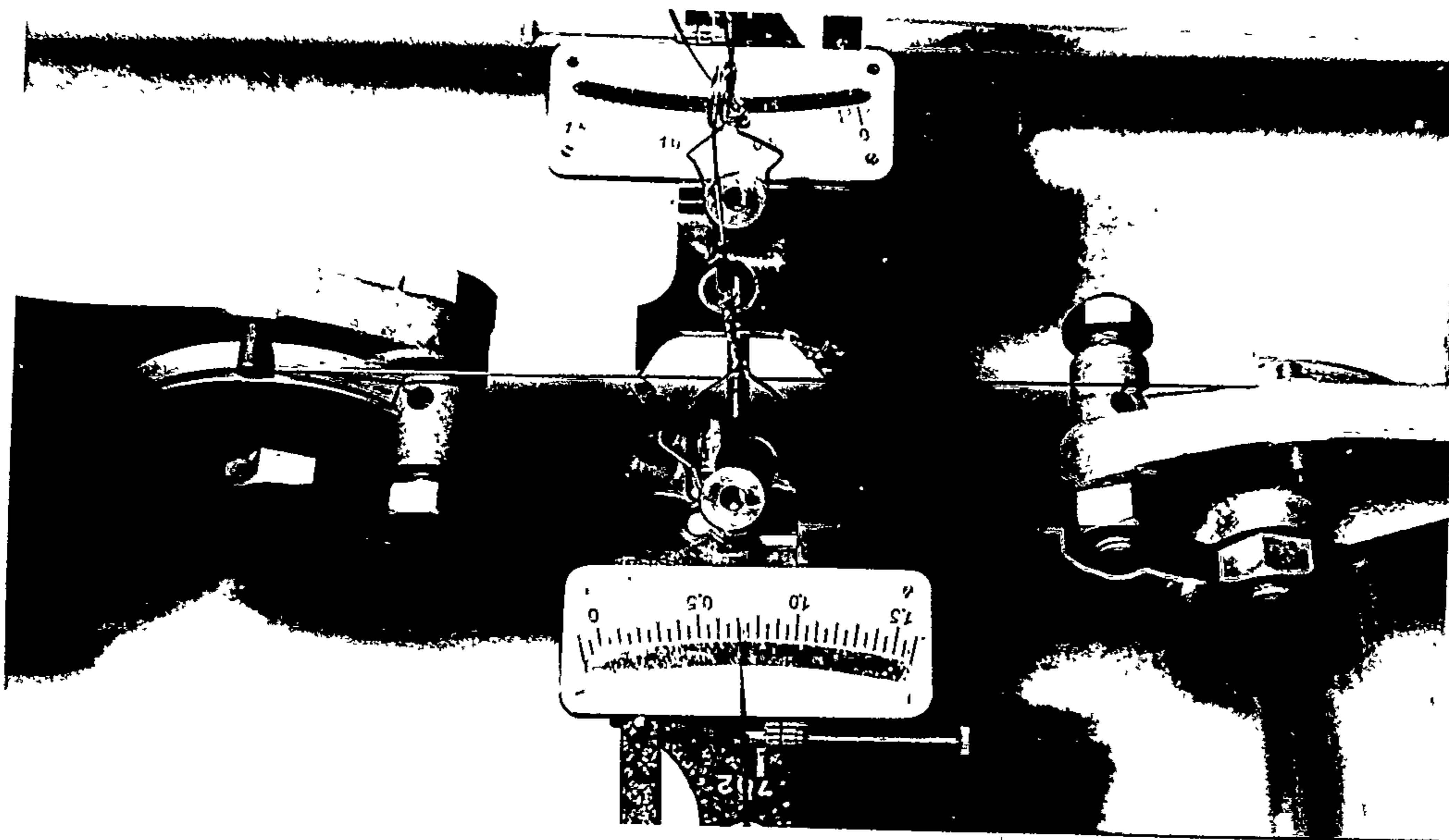

Fig. 7-3 Close-up of Vee-Wire Grips and Huggenberger Extensometers.

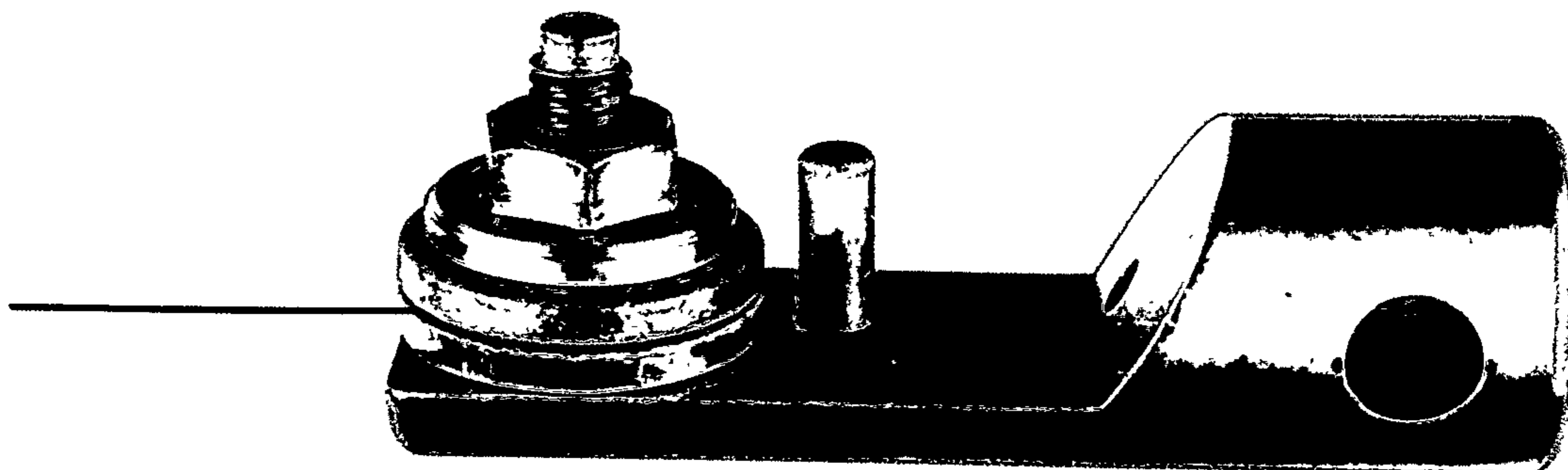

Fig. 7.4. Disc Wire Chuck

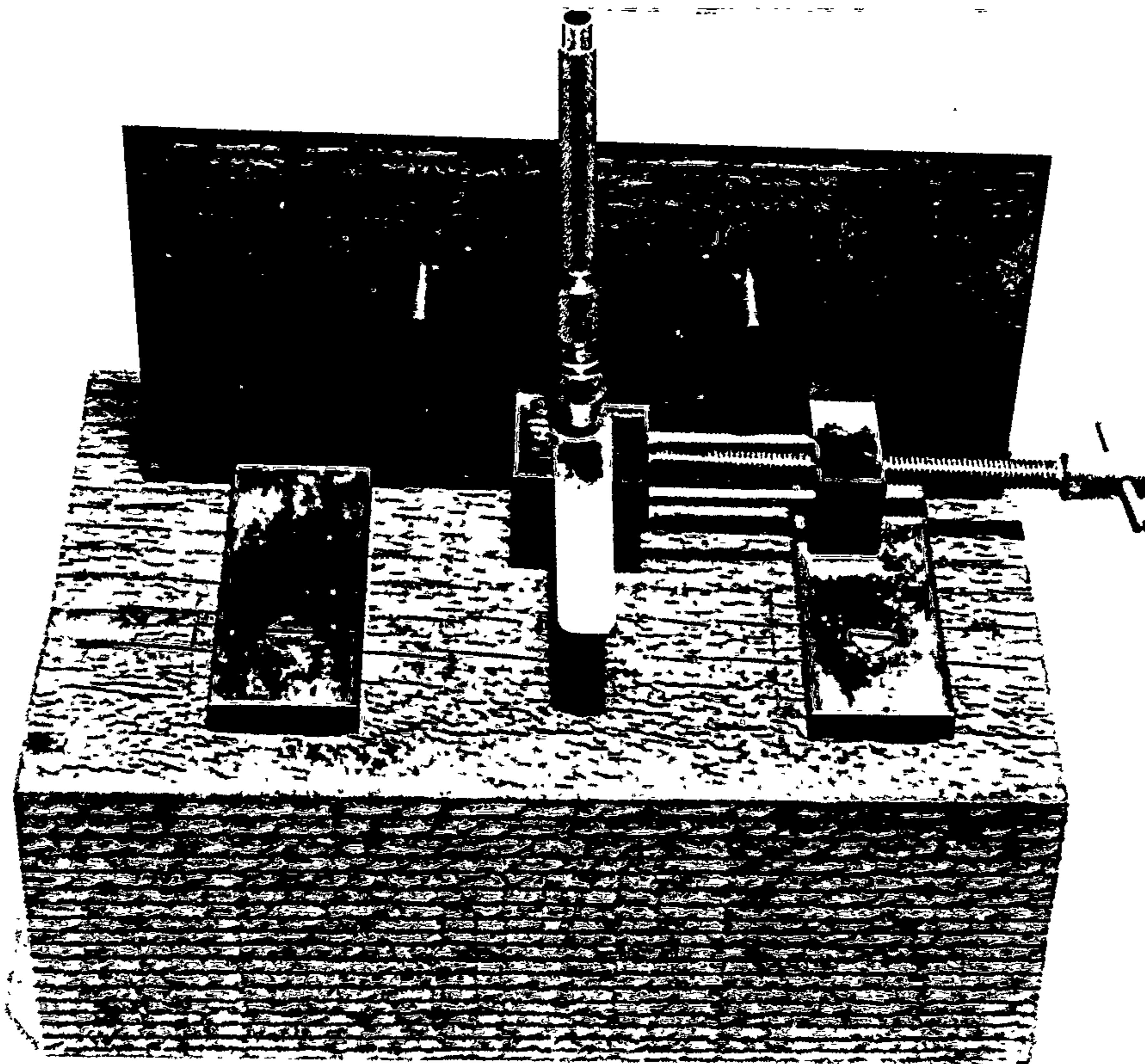

Fig. 7.5 Ductility Testing Apparatus (Cold Bend Test)

### Extensometers

The load was applied manually and at 18lb. load the extensometers were attached to the test wire. The weight of the extensometers on the light wire was counterbalanced by a coiled spring.

The strain was measured by two opposing Huggenberger Type E extensometers (Fig. 7.3). The extensometers were clamped to a one inch length of wire and gave a magnification of 1000.

After each 2 lb. increase in load the readings of the two extensometers were noted, and the extension for the increased load calculated. The mean of the two extensions was added to the progressive total to find the strain for that load.

The sharp edges of the extensometers did not seat well on the hard wire. To overcome this eighth inch lengths of stainless steel tubing (21 gauge hypodermic needles annealed and cut into eighth of an inch lengths) were slipped over the wire and secured with araldite epoxy resin. The sharp edges of the extensometers could thus seat well in the soft steel of the tubes. (A Baty mechanical extensometer which operates on a 2 inch length of wire was tried with early tests. This had proved very satisfactory in the testing of heavier gauge wire (Bröckhurst)(24). This was a dial type of extensometer which clamped onto the wire. It was, however, unsuccessful when clamped onto the .016 inch hard wire).

When it became obvious that the proportional limit had been passed, the Huggenberger extensometers were removed and the load increased until the wire fractured. The total loading was recorded.

Graphs of load versus extension were plotted for each wire. An offset of .02% was selected and proof load determined. The .02% proof load offset was selected as discussed (4.1.8.)

For each type of wire there were six graphs and six results. The values for proof load and ultimate tensile strength, were the mean of the six results for each type of wire.

Youngs modulus of elasticity and proof stress were calculated from the means for each type of wire.

### 7.1.1. Diameter of Wire

The nominal diameter of the wires was .016 inches.

Three measurements of the one inch length between the annealed stainless steel ferrules was made with a micrometer (Moore and Wright) screw gauge which was graduated to 0.001 inch. There was no variation in the same one-inch length, but there were sometimes variations from sample-to-sample of the same wire.

The diameter of the wire taken for calculations was the mean of the six wires tested.

The diameter of wires differed from the nominal diameter, but all were within the tolerance limits of  $\pm 0.0005$  inches as required by the Australian Standard T 32 (75).

### 7.2 Resistance to Failure on Bending

The resistance to failure on bending was determined using the method described in the Australian Standard T 32-1965 (71).

#### 7.2.1. Method

The test wire, one inch in length, was secured in the pin chuck, and then clamped in the pin vise (fig.7.5) so that -

- (a) the wire was vertical
- (b) a distance of .036 inches separated the vise and chuck measured by a brass feeler strip.

The test specimen was moved in the one plane to prevent rotation and collapse of the wire. From the vertical position the test wire was bent to the right through  $40^\circ$ , then to the left through  $80^\circ$ , then back to the vertical position. The complete bending cycle occupied about two seconds. This cycle was repeated until the test wire fractured. Ten samples of each wire were tested and a mean obtained.

### 7.3 Bend Testing

Six samples of each manufacturers wire or wires were subjected to this bend testing.

All wires were tested in the as-received condition with the exception of Elgiloy, which was heat treated according to manufacturers instructions. In addition, two of the wires (Unisil light wire and Unisil Preformed Archwire) tested in as received condition were heat treated and tested. These were the only two wires, apart from Elgiloy, which had not been heat treated by the manufacturer.

Thus there were 11 different wires, and six samples of each making a total of 66 wires tested.

Heat treatment was carried out as follows:-

Elgiloy (Red)  $482^{\circ}\text{C} \pm 2^{\circ}\text{C}$  for 10 minutes

Unisil Light Wire (Coil)  $404^{\circ}\text{C} \pm 2^{\circ}\text{C}$  for 10 minutes

Unisil Performed Light Wire  $404^{\circ}\text{C} \pm 2^{\circ}\text{C}$  for 10 minutes

The heat treatment was carried out as for tensile testing except that  $1\frac{1}{2}$  inch lengths of wire were tied to the thermocouple.

### 7.3.1. Apparatus

Cantilever bend tests have been carried out on Orthodontic wires by investigators (Burstone 1961)(28), (Peyton and Moore 1933)(58), (Ingerslev 1968)(45).

Shell 1940 (69) reports on stiffness testing and its operation from a paper by MacBride who used a Tinius Olsen stiffness Tester. Craig et al 1965 (32) used a Tinius Olsen 6 inch pounds Stiffness Tester to investigate bend properties of .014 inch and .022 inch diameter wire.

In this work a Tinius Olsen 6 inch-pound Capacity Stiffness Testing Machine was used to investigate the bend properties of .016 inch (nominal) stainless steel Orthodontic Wire. A general view of the machine is shown (Fig.7.6.) together with specifications.

In this machine, cantilever bending with the specimen clamped at one end and a load at the free end is the method employed. Load is applied steadily by an electric motor and an indication of the load with resulting angle of bend is given continuously on visual scales (74).

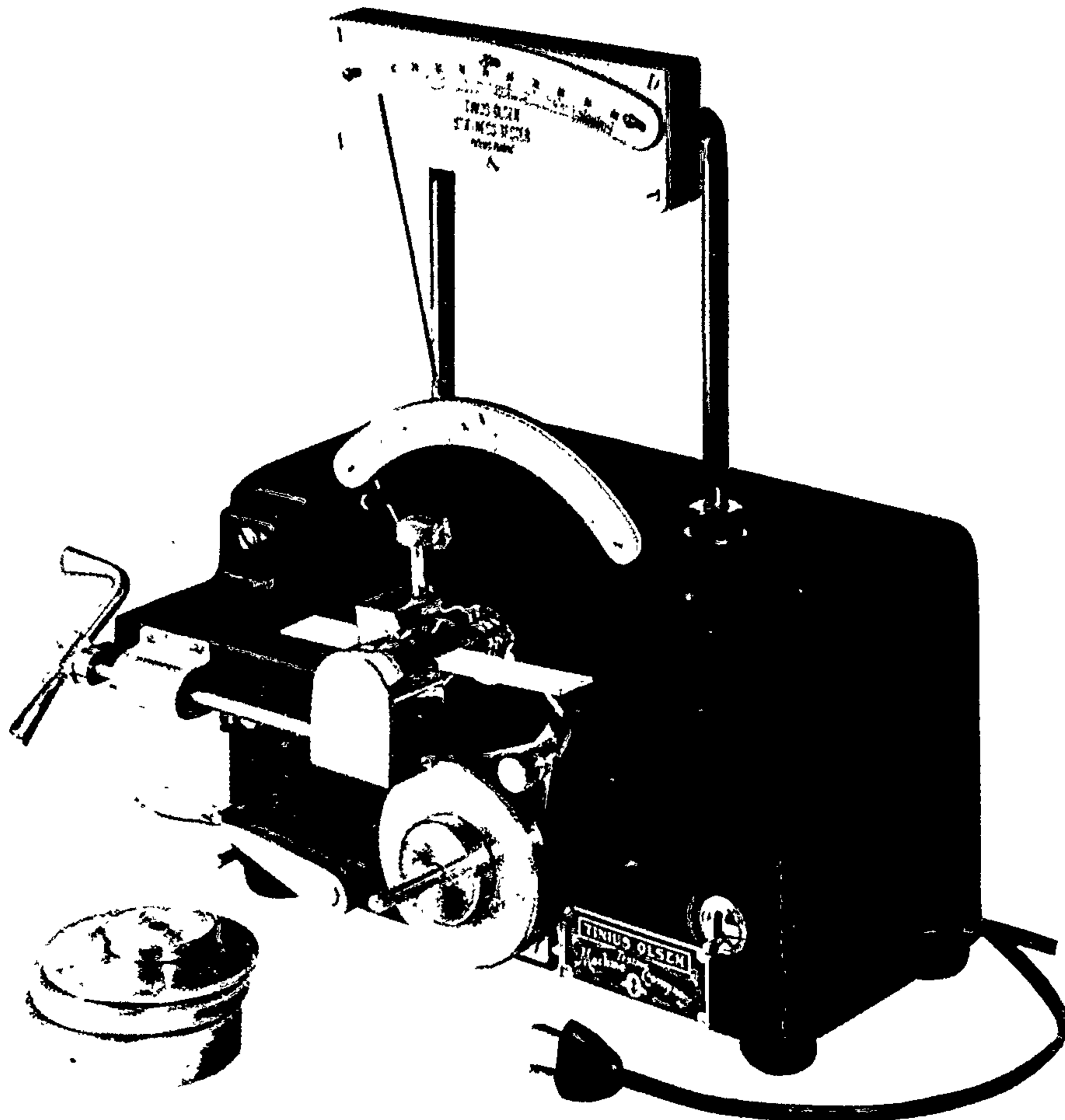

### 6 INCH-POUNDS STIFFNESS TESTER SPECIFICATIONS

**RANGES**—0.10 inch-pounds to 6 inch-pounds by 0.25 inch-pound increments

**LOAD SCALE**—Graduated in 100 divisions

**ANGLE SCALE**—Graduated to 90° by degree increments

**BENDING SPANS**— $\frac{1}{4}$ " ,  $\frac{1}{2}$ " , 1" and 2"

**SPECIMEN VICE**—1" wide

**MOTOR DRIVEN and HAND CONTROL**

**ELECTRICAL REQUIREMENTS**—110 Volts-60 Cycle-  
Single Phase

**HEIGHT**—14"

**WIDTH**—13"

**DEPTH**—9"

**NET WEIGHT**—20 pounds

**SHIPPING WEIGHT**—50 pounds

\* Tour-Marshall-Olsen Patents.

Fig. 7.6 - Tinus Olsen 6 Inch Pounds Stiffness Tester and Specifications.  
(Instructional Manual 74)

### 7.3.2. Test Procedure

Of the spans available ( $\frac{1}{4}$ " ,  $\frac{1}{2}$ " , 1" and 2") (Fig. 7.7) a  $\frac{1}{2}$  inch span was selected having in mind that:-

- (a) Load deflection rate may vary in a given spring wire particularly if large deflections are employed (Burstone)(28).
- (b) Distance crossing dental extraction spaces (i.e. span from bracket on cuspid to bucal tube on molar) would generally be more than  $\frac{1}{4}$  inch in Begg Technique.

That the apparatus was level was determined by placing a spirit level on the load scale indicator.

A weight of .15 in. lb. was added to the pendulum pin. This together with the .1 in. lb. which the machine is designed to apply without external weighting made a total of .25 in. lb. bending moment.

For maximum precision in testing, the bending moment selected should give a load scale reading of between 5% and 10% at an angle of 3 degrees (74). The .25 in. lb. gave a load scale reading of 6-7% at 3 degrees of deflection for the .016 in. wires tested. This moment weight was sufficient to cover all variations found in the test wires up to and beyond the proof load.

The machine is designed to apply the bending moment of .25 in. lb. at the maximum angle of swing ( $30^{\circ}$ ). At this position of the pendulum, the upper fixed scale (Fig. 7.7.) indicates 100% load (74).

The actual pounds load applied at the bending pin, is the load scale reading times the moment used divided by the bending span in inches (7.4.).

$$P = \frac{M}{S} \quad \text{-----(25)}$$

P = Pounds Load

M = Bending moment in in. lbs.

S = Span in inches

The angular deflection of the specimen from zero to 90 degrees is indicated on a scale fixed to the pendulum face. The angle scale pointer turns with the vise, but may be shifted independently of the vise for zero setting (7.4.).

**STIFFNESS TESTER  
6 INCH-POUND CAPACITY**

VICE BRACKET securing screws and driving gear inside case must be removed in event pendulum bearing requires cleaning.

CRANK for hand operation, for adjusting, and for unloading the specimen.

MOTOR CONTROL LEVER

PENDULUM WEIGHTS

Without external weighting, the pendulum is designed to apply, at full swing, a bending moment of 0.1 inch-lb. Placing the 0.15 in.-lb. weight on the pendulum pin gives the next higher range, 0 - 0.25 in.-lb. Additional weights are provided to give various ranges up to 0 - 6 in.-lb. Any loading of the pendulum should include the 0.15 in.-lb. weight.

ANGULAR DEFLECTION SCALE & FRICTION POINTER

SPECIMEN VISE

TINIUS OLSEN

LOAD SCALE adjustable for level setting

BENDING PLATE- has locating holes and dowel for setting to  $\frac{1}{4}$ ",  $\frac{1}{2}$ ", 1" & 2" spans.

To 110v. 60cyc. 1 ph.

Fig. 7.7 - Tinius Olsen 6 Inch Pound Capacity Stiffness Testing Machine (Instructional Manual 74)

The test wires were marked with a marking pencil at one end, checked with the micrometer screw gauge, and clamped firmly in the vise at the point of measurement, so that the wires were approximately parallel to the dial plate.

Those wires that were curved (i.e. all except the Elgiloy) were inserted with the convex side toward the rotation of the vise, so that the test bend was a continuation of the initial bend, thus eliminating any wire manipulation prior to testing.

For accuracy in the tests sufficient load was manually applied to each specimen to show a 1% load reading, before the angle pointer was set to zero.

This point was recorded and plotted as part of the data.

For each specimen the motor lever was engaged and load readings were taken every three degrees up to  $15^{\circ}$ . Load increments were then noted for each degree deflection until it was obvious that the proportional limit had been passed. The loading of the wire was continued up to 80% of the moment weight. From this point the vise was wound back by hand until the load scale pointer indicated 1% again. The permanent set angle resulting from the loading of 80% of .25 in. lb. moment weight was indicated by the deflection pointer.

Initially many tests had to be disregarded, because of a lack of smooth loading of the test wires. This was traced to a frictional effect between the test specimen and bending plate, and was overcome by ensuring a vaselined contact at this point.

Data was plotted on co-ordinate paper with the load scale reading as ordinate and the angular deflection as abscissa.

The steepest straight line was drawn through at least three consecutive points on the plot.

Proof load was determined in the same way as for tensile tests except that .001 inch offset was used. This figure was chosen because it corresponded most closely to 25% strain increment used in determination of proportional limit (4.1.8.).

The load-deflection rate was determined from the graph.

There were six tests for each type of wire, there were six graphs and six results. The proof load and spring rate were taken as the mean of the six results. A value for proof stress and modulus of elasticity in bending was calculated from this mean.

Chapter 8  
8. RESULTS

The results of the investigation are shown in Tables 8.1., 8.2., 8.3., 8.4., 8.5., 8.6., 8.7., 8.8., 8.9., 8.10., and Figures 8.1., 8.2., 8.3., 8.4., 8.5., 8.6.

8.1. Resistance to Failure on Bending

Table 8.1 shows the Resistance to Failure on Bending (mean of 10 tests) and Standard Deviation for each wire.

8.2. Diameter of Wires

Table 8.2. shows the Diameter (mean of 6 tests) and Standard Deviation for each wire.

8.3. Tensile Tests

8.3.1. Proof Load

Table 8.3. shows the Proof Load (mean of 6 tests) and Standard Deviation for each wire.

8.3.2. Ultimate Tensile Strength

Table 8.4. shows the Ultimate Tensile Strength (mean of 6 tests) and Standard Deviation for each wire.

8.3.3. Proof Stress and Modulus of Elasticity

Table 8.5. shows the .02% Proof Stress (mean of 6 tests) and Standard Deviation, also the Modulus of Elasticity (mean of 6 tests) and Standard Deviation for each wire.

8.3.4. Typical Load Strain Curves

Figure 8.1. shows typical load strain curves for 4 Wilcock Wires and 2 Remanit Dentaurem wires.

Figure 8.2. shows typical load strain curves for the 4 wires with the highest .02% proof loads, i.e.

Unisil  
 Dentaurum S.S.H.  
 Wilcock Special Plus  
 Elgiloy (Red) Heat Treated

8.4. Bend Tests

8.4.1. Proof Load

Table 8.6. shows the .001 inch Proof Load (mean of 6 tests) and Standard Deviation for each wire.

The result of eq. 25 was expressed in pounds and converted to grams.

8.4.2. Load Deflection Rate

Table 8.7. shows the Load Deflection Rate (gm./1.1 mm) and Standard Deviation for each wire (mean of 6 tests).

Tests with the Tinius Olsen Bend Test Machine measured deflection in degrees for  $\frac{1}{2}$  inch cantilever.

Using the equation (79)

$$f = 2 \times r \times \frac{\sin \theta}{2}$$

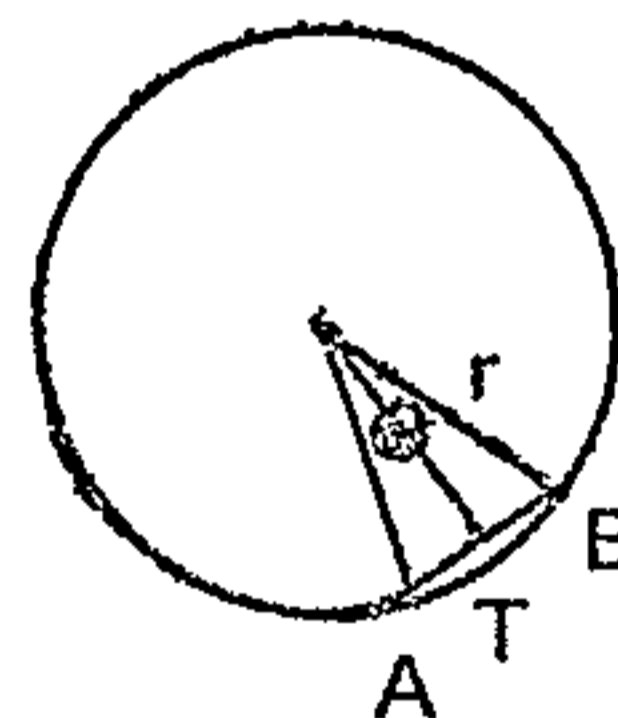

where  $r =$  radius of circle

$\theta =$  angle subtended at centre of the circle by arc at T.

$f =$  deflection A B.

A deflection for 5 degrees of  $\frac{1}{2}$  inch cantilever was obtained in inches and the result converted to m.m. So the load deflection rate was calculated as the load increment (gms.) for each 1.1 m.m. (5 degrees for  $\frac{1}{2}$  inch cantiliver) deflection.

8.4.3. Proof Stress and Modulus of Elasticity

Table 8.8. shows the .001 inch Proof Stress (mean of 6 tests) and Standard Deviation, also the Modulus of Elasticity in Bending (mean of 6 tests) and Standard Deviation for each wire.

#### 8.4.4. Permanent Set

Table 8.9 shows Permanent Set (mean of 6 tests) and Standard Deviation for each wire after 80% loading of .25 in.lb. bending moment -  $\frac{1}{2}$  inch span.

#### 8.4.5. Load Deflection Curves

Figure 8.3 shows typical load deflection curves for the four Wilcock wires.

Figure 8.4 shows typical load deflection curves for the four Unisil wires.

Figure 8.5 shows typical load deflection curves for the two Remanit Dentaurem Wires.

Figure 8.6 shows typical load deflection curve for the Unisil Wire (Unisil (Coil) Heat Treated) with the highest .001 inch proof load, the Dentaurem Wire (Remanit Dentaurem S.S.S.H.) with the highest .001 inch Proof Load, the Wilcock Wire (Wilcock Special Plus) with the highest .001 inch Proof Load, and for Elgiloy with .001 inch Proof Load.

Table 8.1. Results of Tests for Resistance to Failure on Bending

| Trade Name                   | Bends to Fracture<br>Mean of 10 Tests | Standard<br>Deviation |
|------------------------------|---------------------------------------|-----------------------|
| Wilcock Regular              | 34                                    | 2.4                   |
| Wilcock Regular Plus         | 29                                    | 3.2                   |
| Wilcock Special              | 31                                    | 2.09                  |
| Wilcock Special Plus         | 30                                    | 2.4                   |
| Unisil (Coil)                | 25                                    | 2.07                  |
| Unisil (Coil) H.T.           | 26                                    | 2.0                   |
| Unisil Preform Archwire      | 20                                    | 2.2                   |
| Unisil Preform Archwire H.T. | 24                                    | 2.1                   |
| Remanit Dentaurum S.S.H.     | 28                                    | 2.5                   |
| Remanit Dentaurum S.S.S.H.   | 25                                    | 2.3                   |
| Elgiloy (Red)                | 23                                    | 3.8                   |
| Elgiloy (Red) H.T.           | 1                                     | -                     |

Table 8.2. Diameter (inches) of Wires Tested

| Trade Name                                   | Diameter (inches)<br>Mean of 6 Tests | Standard<br>Deviation |
|--|--------------------------------------|-----------------------|
| Wilcock Regular                              | .0162                                | .0001                 |
| Wilcock Regular Plus                         | .0159                                | -                     |
| Wilcock Special                              | .0160                                | .0001                 |
| Wilcock Special Plus                         | .0159                                | -                     |
| Unisil (Coil)                                | .0162                                | -                     |
| Unisil (Coil) Heat Treated                   | .0162                                | -                     |
| Unisil Preform Archwire                      | .0160                                | .0001                 |
| Unisil Preform Archwire H.T.<br>Heat Treated | .0160                                | .0001                 |
| Remanit Dentaurem S.S.H.                     | .0155                                | .0002                 |
| Remanit Dentaurem S.S.S.H.                   | .0155                                | -                     |
| Elgiloy (Red) Heat Treated                   | .0159                                | .0002                 |

Table 8.3. Result of Tensile Tests  
Grading according to Proof Load

| Trade Name                 | .02% Proof Load (lbs.)<br>Mean of 6 Tests | Standard<br>Deviation |
|----------------------------|---|-----------------------|
| Unisil (Coil)              | 55  | 1.3                   |
| Remanit Dentaurum S.S.H.   | 54  | 1.3                   |
| Wilcock Special Plus       | 48  | 1.4                   |
| Elgiloy (Red) Heat Treated | 48  | 1.4                   |
| Remanit Dentaurum S.S.S.H. | 45  | 1.3                   |
| Wilcock Special            | 40  | 1.9                   |
| Wilcock Regular            | 40  | 1.4                   |
| Wilcock Regular Plus       | 38  | 1.3                   |

Table 8.4. Result of Tensile Tests  
Grading according to Ultimate Tensile Strength

| Trade Name                 | Ultimate Tensile<br>Strength $10^3$ lbs/in <sup>2</sup><br>Mean of 6 Tests | Standard<br>Deviation |
|----------------------------|--|-----------------------|
| Unisil (Coil)              | 402  | 1.9                   |
| Wilcock Special Plus       | 392  | 1.5                   |
| Remanit Dentaurum S.S.S.H. | 371  | 2.7                   |
| Wilcock Special            | 363  | 5.1                   |
| Elgiloy (Red) Heat Treated | 352  | 2.5                   |
| Wilcock Regular Plus       | 343  | 2.5                   |
| Wilcock Regular            | 329  | 3.4                   |
| Remanit Dentaurum S.S.S.H. | 320  | 5.2                   |

Table 8.5. Result of Tensile Tests

| Trade Name                 | .02% Proof Stress<br>10 <sup>3</sup> lbs/in <sup>2</sup><br>Mean of 6 Tests | S.D. | Modulus of<br>Elasticity<br>10 <sup>6</sup> lbs/in <sup>2</sup><br>Mean of 6<br>Tests | S.D. |
|----------------------------|---|------|---|------|
| Wilcock Regular            | 194.0   | 9.1  | 24.7  | .76  |
| Wilcock Regular Plus       | 189.0   | 8.7  | 25.1  | .78  |
| Wilcock Special            | 199.0   | 8.8  | 25.3  | .88  |
| Wilcock Special Plus       | 242.3   | 7.5  | 26.2  | .75  |
| Unisil (Coil)              | 269.3   | 6.5  | 25.8  | .77  |
| Remanit Dentaurum S.S.H.   | 286.1   | 6.8  | 27.6  | .73  |
| Remanit Dentaurum S.S.S.H. | 238.5   | 6.8  | 25.2  | .78  |
| Relgiloy (Red) H.T.        | 242.0   | 5.4  | 24.9  | .52  |

Table 8.6. Result of Bend Tests  
Grading According to Proof Load

| Trade Name                              | .001" Proof Load (gms.)<br>Mean of 6 Tests | Standard<br>Deviation |
|---|--|-----------------------|
| Unisil (Coil) Heat Treated              | 165  | 4.1                   |
| Unisil Preform Archwire<br>Heat Treated | 165  | 4.3                   |
| Unisil (Coil)                           | 149  | 5.3                   |
| Unisil Preform Archwire                 | 143  | 3.4                   |
| Dentaurum S.S.S.H.                      | 142  | 5.6                   |
| Wilcock Special Plus                    | 131  | 6.7                   |
| Elgiloy (Red) Heat Treated              | 120  | 3.6                   |
| Dentaurum S.S.H.                        | 120  | 5.1                   |
| Wilcock Special                         | 110  | 6.9                   |
| Wilcock Regular                         | 106  | 5.4                   |
| Wilcock Regular Plus                    | 105  | 4.8                   |

Table 8.7. Load Deflection Rate (gm/1.1mm)

Listed according to Load Deflection Rate (gm/1.1 mm)

| Trade Name                              | Load Deflection Rate<br>Mean of 6 Tests | Standard<br>Deviation |
|---|---|-----------------------|
| Unisil (Coil) Heat Treated              | 31.2                                    | 1.1                   |
| Unisil (Coil)                           | 30.6                                    | 1.2                   |
| Wilcock Special Plus                    | 29.7                                    | 1.3                   |
| Unisil Preform Archwire<br>Heat Treated | 29.4                                    | 1.2                   |
| Wilcock Regular                         | 28.2                                    | 1.2                   |
| Wilcock Regular Plus                    | 27.7                                    | 1.3                   |
| Unisil Preform Archwire                 | 27.6                                    | 1.2                   |
| Elgiloy (Red) Heat Treated              | 26.6                                    | 1.2                   |
| Wilcock Special                         | 26.4                                    | 1.2                   |
| Remanit Dentaurem S.S.H.                | 26.0                                    | 1.1                   |
| Remanit Dentaurem S.S.S.H.              | 24.9                                    | 1.1                   |

Table 8.8. Result of Bend Tests

| Trade Name                   | .001" Proof Stress<br>10 <sup>3</sup> lbs/in <sup>2</sup><br>Mean of 6 Tests | S.D. | Modulus of<br>Elasticity<br>10 <sup>6</sup> lbs/in <sup>2</sup><br>Mean of 6<br>Tests | S.D. |
|------------------------------|--|------|---|------|
| Wilcock Regular              | 276  | 23   | 17.6  | .8   |
| Wilcock Regular Plus         | 317  | 20   | 18.7  | .8   |
| Wilcock Special              | 319  | 24   | 17.7  | .8   |
| Wilcock Special Plus         | 367  | 20   | 19.8  | .6   |
| Unisil (Coil)                | 385  | 15   | 18.7  | .6   |
| Unisil (Coil) H.T.           | 420  | 16   | 20.8  | .7   |
| Unisil Preform Archwire      | 372  | 18   | 19.1  | .7   |
| Unisil Preform Archwire H.T. | 441  | 18   | 20.1  | .7   |
| Remanit Dentaurem S.S.H.     | 376  | 19   | 20.7  | .8   |
| Remanit Dentaurem S.S.S.H.   | 424  | 21   | 18.8  | .7   |
| Elgiloy (Red)                | 335  | 23   | 18.7  | .7   |

Table 8.9. Result of Bend Tests

Permanent Set (mm) after 80% Loading of .25 in. lb.

Bending Moment -  $\frac{1}{2}$  inch Span

| Trade Name                   | Permanent Set (mm.)<br>Mean of 6 Tests | Standard<br>Deviation |
|------------------------------|--|-----------------------|
| Wilcock Regular              | 1.6                                    | 0.3                   |
| Wilcock Regular Plus         | 1.1                                    | 0.3                   |
| Wilcock Special              | 0.99                                   | 0.2                   |
| Wilcock Special Plus         | 0.33                                   | -                     |
| Unisil (Coil)                | 0.22                                   | -                     |
| Unisil (Coil) Heat Treated   | 0.11                                   | -                     |
| Unisil Preform Archwire      | 0.89                                   | 0.2                   |
| Unisil Preform Archwire H.T. | 0.11                                   | -                     |
| Remanit Dentaurem S.S.H.     | 10.30 at 78% load                      | -                     |
| Remanit Dentaurem S.S.S.H.   | .55                                    | 0.1                   |
| Elgiloy (Red) Heat Treated   | .33                                    | 0.1                   |

Table 8.10. Result of Tensile and Bend Tests

Grading according to Tensile and Bend Elastic Strength

| <u>Bend Test</u>                         |                                      | <u>Tensile Test</u>                         |                                      |
|--|--------------------------------------|---|--------------------------------------|
| Trade Name                               | Proof Load (gms.)<br>Mean of 6 Tests | Trade Name                                  | Proof Load (lbs.)<br>Mean of 6 Tests |
|  |                                      | I   |                                      |
| Unisil (Coil)                            | 149                                  | Unisil (Coil)                               | 55                                   |
|  |                                      | II  |                                      |
| Dentaurum (Super<br>Special Spring Hard) | 142                                  | Dentaurum (Super<br>Spring Hard)            | 54                                   |
|  |                                      | III   |                                      |
| Wilcock Special Plus                     | 131                                  | Elgiloy (Red)                               | 48                                   |
|  |                                      | Wilcock Special Plus                        | 48                                   |
|  |                                      | IV  |                                      |
| Elgiloy (Red)                            | 120                                  | Dentaurum<br>(Super Special<br>Spring Hard) | 45                                   |
| Dentaurum (Super<br>Spring Hard)         | 120                                  |   |                                      |
|  |                                      | V   |                                      |
| Wilcock Special                          | 110                                  | Wilcock Regular                             | 40                                   |
|  |                                      | Wilcock Special                             | 40                                   |
|  |                                      | VI  |                                      |
| Wilcock Regular                          | 106                                  | Wilcock Regular Plus                        | 38                                   |
|  |                                      | VII   |                                      |
| Wilcock Regular<br>Plus                  | 105                                  |   |                                      |

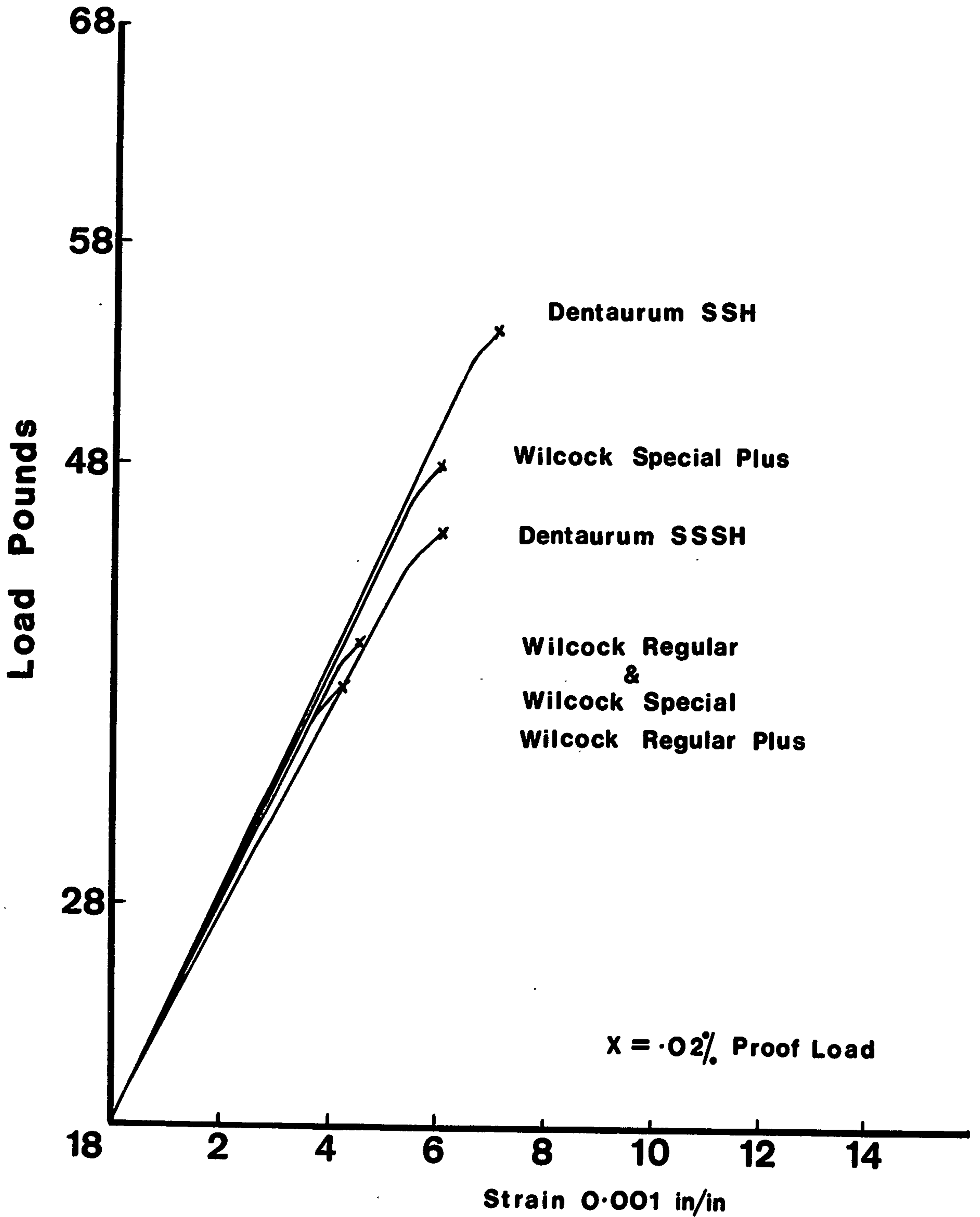

**Fig. 8-1**

**Typical Load Strain Curves**

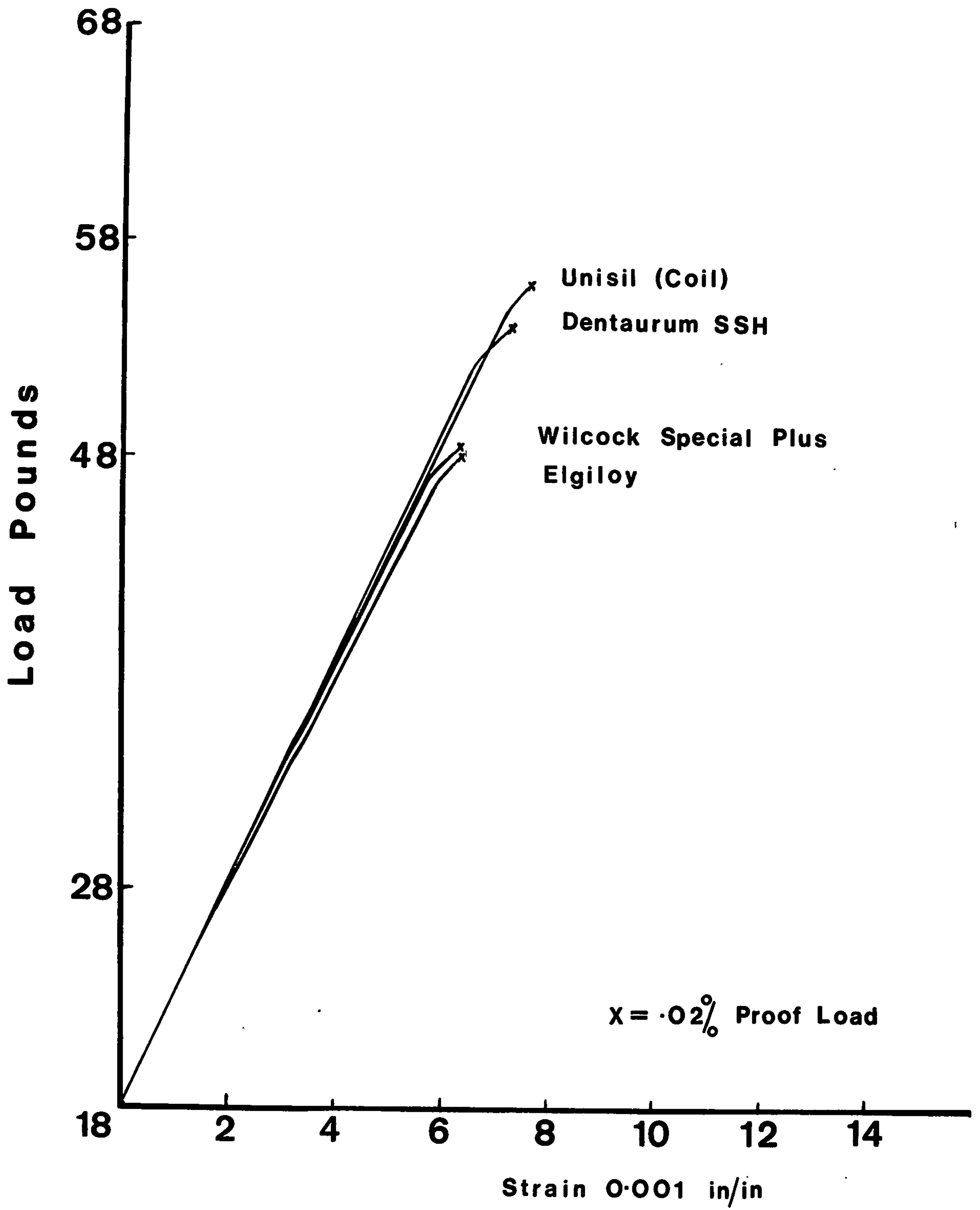

**Fig. 8-2**

**Typical Load Strain Curves**

# Bending Moment Percentage of .25 Inch Pounds

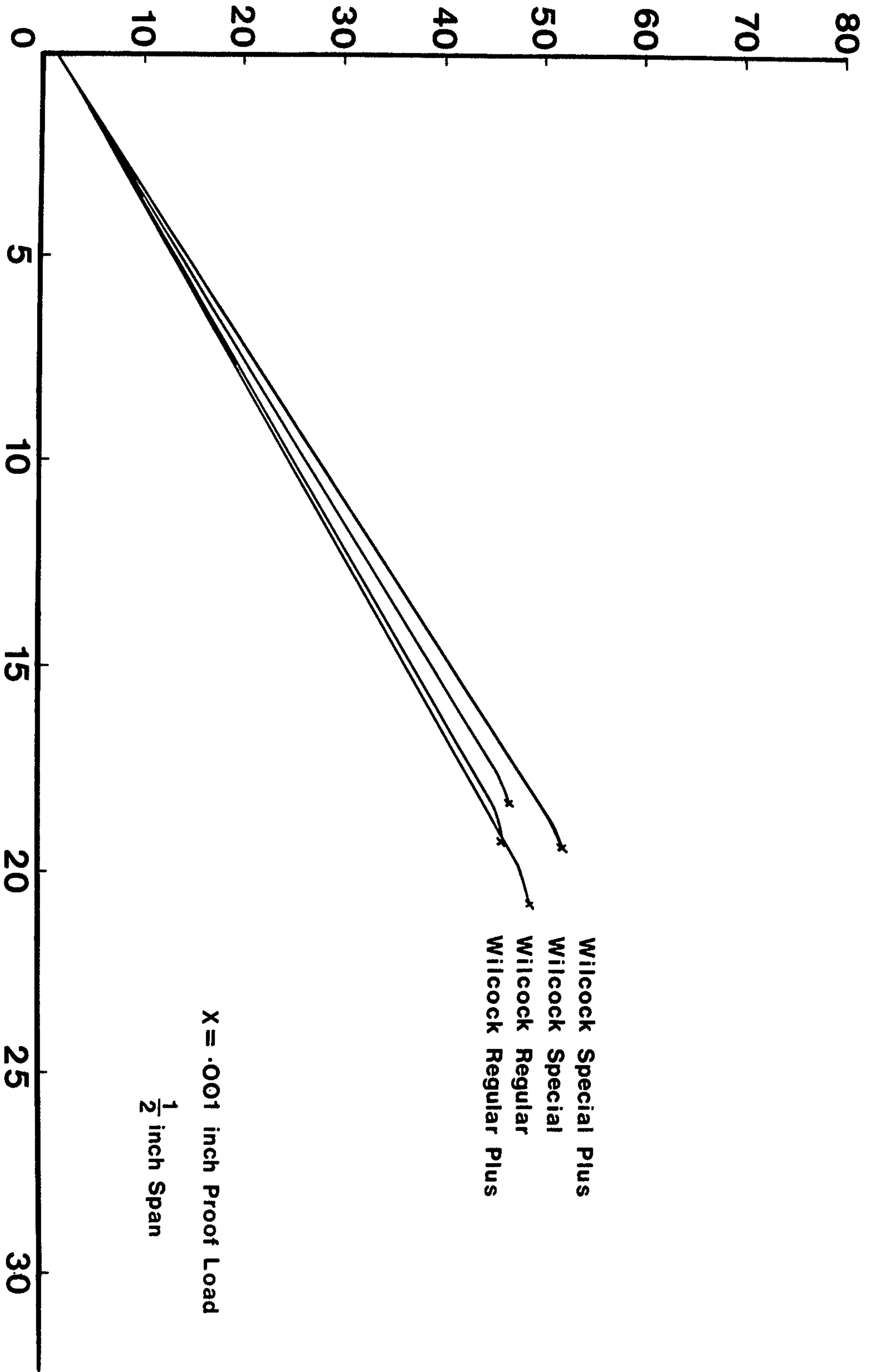

Fig. 8-3

Angular Deflection Degrees

X = .001 inch Proof Load

1/2 inch Span

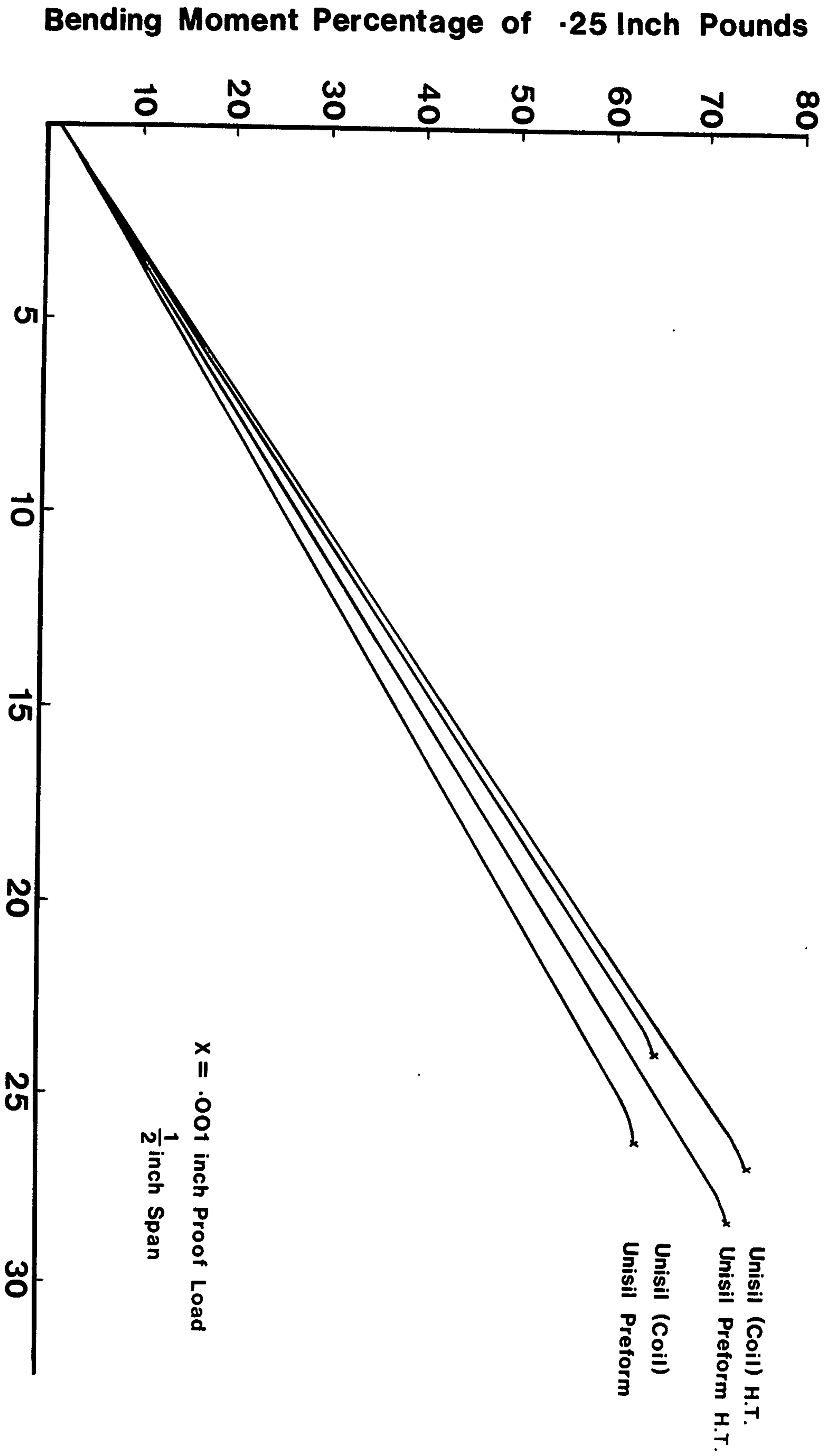

Fig. 8-4

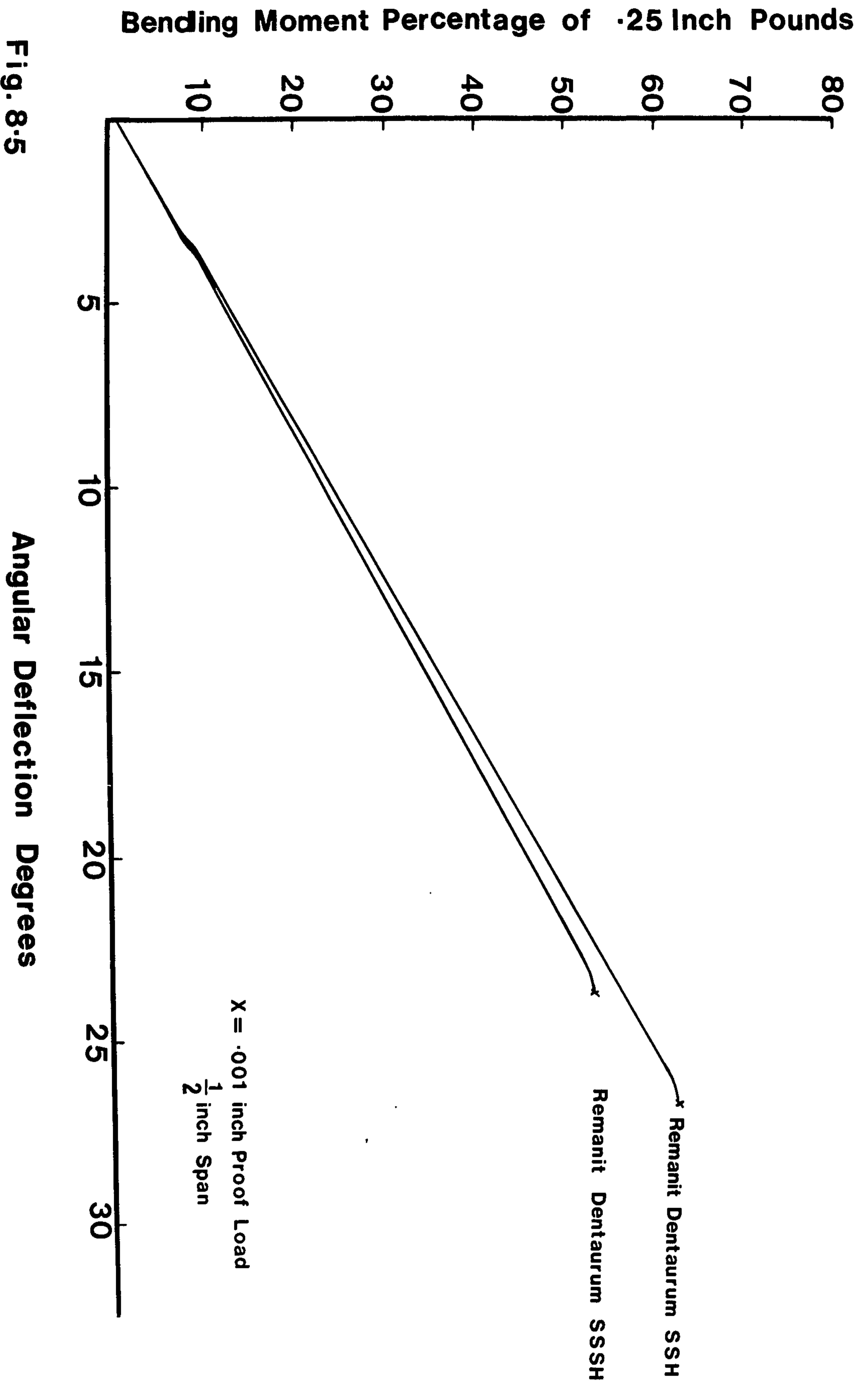
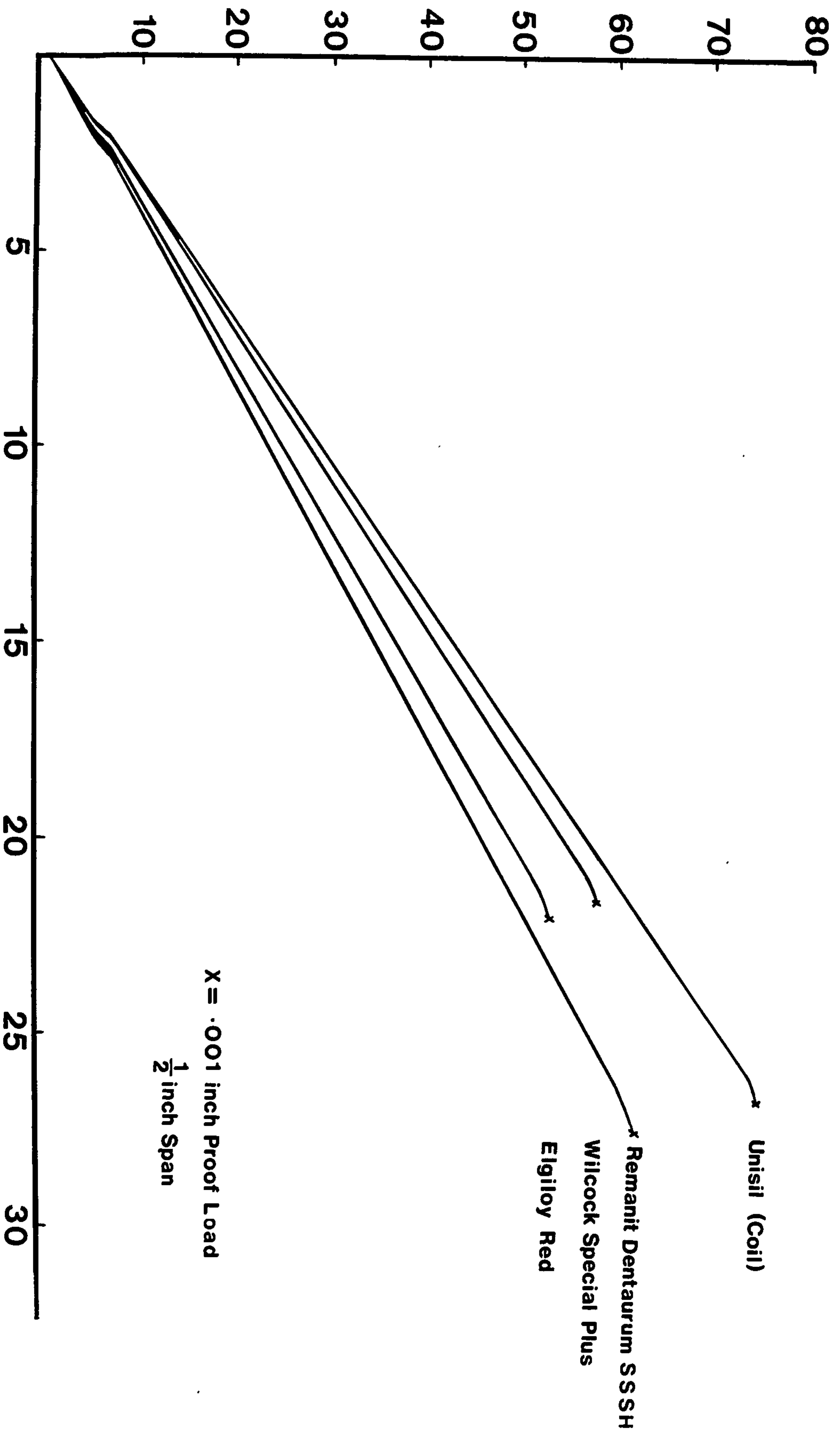

Fig. 8.5

Bending Moment Percentage of .25 Inch Pounds

Fig. 8.6

Angular Deflection Degrees



X = .001 inch Proof Load  
1/2 inch Span

## Chapter 9

### 9. CLINICAL SIGNIFICANCE OF RESULTS

#### 9.1. Ductility

The Resistance to Failure on Bending Tests indicate that the ductility of all wires examined meets the requirements of the Australian Standard T.32 - 1965 (Table 8.1.).

Elgiloy (Red), however, after heat treatment, would be too brittle for any but minimum adjustments.

#### 9.2. Elastic Strength

A comparison of Tensile and Bend Test Results (Table 8.10.) with eight wires showed:-

Grading of the .016 inch (nominal diameter) wires according to elastic tensile strength (.02% Proof Load) did not coincide exactly with the elastic strength (.001 inch Proof Load) in bending.

Four wires coincided in their grading (Unisil, Wilcock Special Plus, Wilcock Special, Wilcock Regular Plus) but the other four did not.

Consequently, it must be concluded that Orthodontic Wires should be graded on their elastic strength in bending and not on their tensile strength.

Archwires constructed of the wires tested would be least likely to fail from plastic distortion according to the bend strength grading (Table 8.6.) This showed Unisil (Coil) Heat Treated to have the greatest strength and Wilcock Regular Plus the least.

#### 9.3. Load Deflection Rate (Stiffness)

The wires are listed according to their load deflection rate Table 8.7.

If archwires are constructed of these wires, and subjected to a given deflection, Unisil (Coil) Heat Treated, would exert the greatest force, and would continue to do so for every unit of unloading.

Remanit Dentaurem (Super Special Spring Hard) would exert the least force for the same deflection. However, the decrease in force for every unit of unloading would be less, and consequently the wire would exert a more constant force.

Table 9.4. Permanent Set with the same Loading

Table 8.9 indicates the plastic distortion of each wire after the same loading.

It is reasonable to assume that if an archwire constructed of the wire with the lowest permanent set (Unisil - heat treated), were subjected to a loading sufficient to cause a slight permanent set, the appliance would continue to operate but at reduced efficiency.

If these same conditions of loading were applied to an archwire with the highest permanent set (Remanit Dentaurem - Super Spring Hard), the appliance would not operate at all.

If these circumstances were to apply at the spanning of extraction spaces in the Begg Technique, the importance of correct wire selection becomes obvious.

9.5. Comment

9.5.1. The Best Wire For The Technique

An optimum load deflection rate (or range for load deflection rate) that is required of an archwire should be established for the particular circumstances of the orthodontic technique.

Then the wire with the required load deflection rate and the greatest strength in bending would be the best wire for the technique.

9.5.2. Standardisation of Wires

Wires from the same manufacturer vary markedly in performance from batch to batch. (Burstone)(56), (Kohl)(64), Howe et al) (31).

Greater standardisation of both quality and diameter of the wires would result in a wire with less change in performance. A variation in diameter affecting the stiffness of a wire is well demonstrated with Unisil (Coil) and Wilcock Special Plus wires. The modulus of elasticity (calculated from both Tensile and Bend Tests) show Wilcock Special Plus wire material (.0159 inch diameter) to be stiffer than

Unisil (Coil) material (.0162 inch diameter). The load deflection graph (Fig. 8.6) shows the position to be the reverse with Unisil the stiffer wire.

If it was indicated in applying the Begg Technique that the round .016 inch wire should have:-

- (a) a load deflection rate within a certain range
- (b) a minimum strength

then the manufacturer is better able to market a product to meet requirements.

This reasoning could be applied to the grading of wires for any orthodontic technique employing light resilient wires.

### 9.5.3. Ultimate Tensile Strength

Light wire techniques use wires with little or no margin for safety as regards strength. They are subjected to loads right up to their elastic limit and beyond. Loading of the light wire beyond the elastic limit, (e.g. bite opening bends bitten out across extraction spaces in the Begg Technique) results in failure of the technique.

Thus the elastic strength of the wires should be measured as accurately as possible.

The Ultimate Tensile Strength was seen not to be an accurate means of grading the wires tested (Table 8.4.), judged from the elastic bend strength grading.

The Australian Standard (A.S.T.32 - 1965)(72) for Resilient Orthodontic Wires classifies wires according to their Ultimate Tensile Strength as follows:-

Table 9.1. Tensile Strength of Orthodontic Wires

| Type of Wire | Tensile Strength                |                      |                     |
|--------------|---------------------------------|----------------------|---------------------|
|              | lbs/in <sup>2</sup><br>(.000's) | tons/in <sup>2</sup> | Kgs/mm <sup>2</sup> |
| A            | 250-325                         | 112-145              | 176-228             |
| B            | 326-370                         | 146-165              | 229-260             |
| C            | 371-390                         | 166-174              | 261-274             |
| D            | 391 and over                    | 175 and over         | 275 and over        |

Unisil (Coil) would be classified Type D according to its Ultimate Tensile Strength (Table 8.4.) and had first grading from both Tensile and Bend Tests.

Wilcock Special Plus (second highest Ultimate Tensile Strength Table 8.4.) would also be classified Type D. This wire had the third highest proof loading in both Tensile and Bend Tests.

However, Dentaurum (S.S.S.H.), the wire graded second in Bend Tests would be classified Type C, and Dentaurum (S.S.H.) graded second in Tensile Tests would be classified Type A.

Consequently it is considered that wires for the Begg Technique should be classified according to their elastic strength in bending and this should be included in the Australian Standard.

#### 9.5.4. Proof Stress and Modulus of Elasticity

It is interesting to note that values for Proof Stress and Modulus of Elasticity differ for Tensile (Table 8.5.) and Bend Tests (Table 8.8.), with Proof Stress being higher and Modulus of Elasticity lower for Bend Tests.

#### 9.5.5. Indications for Future Work

There is a need for the establishment of an optimum range for load deflection rate, for the .016 inch round wire to be used in the Begg Technique.

## Chapter 10

### 10. SUMMARY

1. Tensile and Bend Tests were carried out on selected light wires to aid in the selection of wires for the Begg Technique.
2. Grading of wires according to Tensile Elastic Strength did not agree with the grading from elastic strength in Bending.

As the bend properties of wire determine the success of the Begg Technique (and all light wire techniques), it was decided that wires should be selected according to their elastic strength in bending and the strongest wire would be the most suitable wire.

3. From the Bend Test Results it was found that:-
  - (a) The wires with the greatest elastic strength were  
Unisil (Coil) Heat Treated  
Unisil Preformed Archwire Heat Treated
  - (b) Of the wires tested in the "as received condition" the one with the greatest elastic strength was  
Unisil (Coil)

4. The load deflection rates of all wires were listed, and it was indicated that more work was needed to determine the optimum range for load deflection rate for the technique.

Of the wires tested

- (a) Unisil (Coil) Heat Treated had the highest load deflection rate.
  - (b) Remanit Dentaurem Super Special Spring Hard had the lowest load deflection rate.
  - (c) Of the wires tested in the "as received condition" Unisil (Coil) had the highest load deflection rate.
5. It was found that all wires were sufficiently ductile, meeting the requirements of the Australian Standard T.32, but that Elgiloy (Red) after heat treatment would only tolerate minimum adjustments.

6. Grading of wires by Ultimate Tensile Strength (the present method) was not in accord with grading by elastic strength in bending. Since the bend properties of wire are used in the Begg Technique (and in all light wire techniques) it was decided that the classification of wires for the technique should be by elastic strength in bending, and that this change should be made in the Australian Standard.

## BIBLIOGRAPHY

1. Anderson, G.M.: Practical Orthodontics. St. Louis, The C.V. Mosby Co., 7th ed., 1948 (P.56).
2. *ibid* (P.57)
3. *ibid* (P.60)
4. *ibid* (P.60)
5. *ibid* (P.61)
6. *ibid* (P.62)
7. *ibid* (P.54)
8. Angell, R.C.: Comparison of Gold Alloy and Stainless Steel Wire for Orthodontic Arches and Springs. *J. Dent. Res.*, 29:2, 143-147 (April) 1950.
9. Atkinson, S.R.: The Strategy of Orthodontic Treatment. *J. Am. Dent. Ass.*, 24: 560-574, (April) 1937.
10. Armco Selection Guide, Armco Precipitation Hardening Stainless Steels, Armco Steel Corporation, Advanced Materials Division, Baltimore, Maryland.
11. Armco (Aust.) Pty. Ltd., Bailey, M.H. Personal Communication. P.O. Box 2, Sutherland, Sydney, N.S.W. (1972)
12. Backofen, W.A. and Gales G.F.: The Low Temperature Heat Treatment of Stainless Steel for Orthodontics. *Angle Orthod.*, 21:2, 117-124 (April) 1951.
13. Begg, P.R.: Stone Age Man's Dentition. *Am. J. Orthod.* 40:7, 517-531 (July) 1954.
14. Begg, P.R.: Begg Orthodontic Theory and Technique. Philadelphia, W.B. Saunders Co., 1965 (P.87).
15. *ibid* (P.89)
16. *ibid* (P.92)
17. *ibid* (P.171)
18. *ibid* (P.105-108)
19. Begg, P.R., Kesling, P.C.: Begg Orthodontic Theory and Technique. Philadelphia, W.B. Saunders Co., 2nd ed. 1971 (P.95).
20. Billberg, B.: The Mechanical Properties of Stainless Steel Wire used in Orthodontic Practice. *Svensk Tandlak. Tidskr.* 1:55, 197-210 (Aug.) 1962.
21. Braddick, H.J.J.: The Physics of Experimental Method. Chapman and Hall, London, 1954 (P.95-96).

22. Brockhurst, P.J.: Retentive Clasp Arms for Cast Alloy Partial Dentures. Ph.D. 1970. University of Sydney. (P.131-133).
23. *ibid* (P.114-115).
24. *ibid* (P.100).
25. Brockhurst, P.J.: Personal Communication (1972).
26. Brumfield, R.C.: Dental Gold Structures, Analysis and Practicalities, New York, J.F. Jelenko and Co. Inc., 2nd ed., 1953 (P.34).
27. *ibid* (P.146-147).
28. Burstone, C.J., Baldwin, J.J., and Lawless, D.T.: The Application of Continuous Forces to Orthodontics. *Angle Orth.*, 31:1, (Jan.) 1961 (P.1-14).
29. Burstone, C.J., and Groves, M.H. Jr.: Threshold and Optimum Force Values for Maxillary Anterior Tooth Movement, *J.D. Res.* 39 : 695. 1960 abs.
30. Bush, S.H., Taylor, D.F. and Peyton F.A.: A Comparison of the Mechanical Properties, Chemical Composition and Microstructures of Dental Gold Wires. *J. Pros. Dent.* 1 : 1 and 2, 177-187 (Jan. and March) 1951.
31. Coutsouradis, D., Drapier, J.M., Diderrick, E. and Habraken, L.: Precipitation Hardening in High Strength Stainless Steels. Reprinted from *COBALT*, No.36, September, 1967, P.144-156. Published by "Centre D'Information Du Cobalt", Brussels.
32. Craig, R.G. et al: Application of 17/7 Precipitation Hardenable Stainless Steel in Dentistry. *J. Dent. Res.*, 44, 587-595 (May, June) 1965.
33. Delgado, V.P. and Anderson, J.N.: Tensile and Bending Properties of Stainless Steel Orthodontic Wires. *Brit. Dent. J.*, 114 : 10, 401-406, (May) 1963.
34. Dentaurem Remanit. Catalogue -- Orthodontics, Firma Dentaurem, Pforzheim, W. Germany.
35. De Coster, L.: The Use of Rustless Steel in Dentofacial Orthopedics. *Int. J. Orth.*, 18 : 11, 1191-1195, (Nov.) 1932.
36. Earnshaw, R.: Notes on Dental Metallurgy. Sydney. University of Sydney, 2nd ed., 1967 (P.12-16).
37. *ibid* (P.42-43)
38. Friel, S.: The Practical Application of Stainless Steel in the Construction of Fixed Orthodontic Appliances *Dent. Rec.* 23:7, 321-323, 1933.
39. Funk, A.C.: The Heat Treatment of Stainless Steel, *Angle Orthod.*, 21:3, 129-138 (July) 1951.
40. Gaston, N.G.: Chrome Alloy in Orthodontics. *Am. J. Orth.*, 37:10, 779-796 (Oct.) 1951.

41. Graber, T.M.: Orthodontic Principles and Practice. Philadelphia, W.B. Saunders Co., 1961, (P.424).
42. Greener, E.H. and Hillam H.G.: Relationship of Structure to Physical Properties of Soldered Cobalt Chromium Orthodontic Wires. XVIII Biomaterials, North Western University Chicago, Illinois 60611.
43. Haack, D.C.: The Science of Mechanics and its Importance to Analysis and Research in the Field of Orthodontics. Am. J. Orth., 49:5, 330-344 (May) 1963.
44. Howe, G.L. et al: Mechanical Properties and Stress Relief of Stainless Steel Orthodontic Wire. Angle Orthod., 38 : 3, 244-249 (July) 1968.
45. Ingerslev, C.H.: Influence of Heat Treatment on the Physical Properties of Bent Orthodontic Wire. Angle Orthod., 36:3, 237-247 (July) 1968.
46. Jarabak, J.H. and Fizzell, J.A.: Technique and Treatment with Light Wire Appliances. St. Louis, The C.V. Mosby Co., 1963.
47. Johnson, J.E.: Twin Arch Appliance Am. J. Orthod. and Oral Surg. 24:4. 303-327 (April) 1938.
48. Kemler, E.A.: Effect of Low Temperature Heat Treatment on the Physical Properties of Orthodontic Wire. Am.J. Orthod., 42:10, 793, (Oct.) 1956 (abstract).
49. Kohl, R.W.: Metallurgy in Orthodontics. Angle Orthod., 34:1, 37-52.
50. Mahler, D.B. and Goodwin, L.: An Evaluation of Small Diameter Orthodontic Wires. Angle Orthod. 37:1, 13-17 (Jan.) 1967.
51. Masson, R.J.: An Evaluation of .016 inch Orthodontic Light Wires. M.D.Sc. Thesis 1969 University of Sydney.
52. Metals Handbook, Vol.1.: Properties and Selection of Materials. 8th ed. Lynman, T., ed. Ohio American Society of Metals, 1961 (P.39).
53. ibid (P.43)
54. Moneypenney, J.H.G.: Stainless Iron and Steel. London, Chapman and Hall Ltd., 1 : 3rd ed., 1951 524 (P.3-57).
55. Mutchler, R.W.: The Effect of Heat Treatment on the Mechanical Properties of Orthodontic Cobalt-Chromium Steel Wires as compared with Chromium Nickel Steel Wire. Northwest Univ. Bull., 61:26, 5-11 (Fall) 1961.
56. Newman, C.V.: A Biomechanical Analysis of the Begg Light Wire Technique. Am. J. Orthod., 49:10, 721-740 (Oct.) 1963.
57. Paffenbarger, G.C., Caul, H.J. and Dickson, G.: Base Metal Alloys for Oral Restorations. J.A.D.A. 30:11, 852-862 (June) 1943.
58. Peyton, F.A. and Moore, G.R.: Flexibility Studies on Gold Alloy Wires and Orthodontic Appliances. Int. J. of Orthodont and Dent. Children. 19:8, 779-794 (Aug.), 1933, 19:9, 903-919, (Sept.) 1933.

59. Pollock, H.C.: The Practical Use of Tungsten and Molybdenum in Orthodontic Appliances. *Inter. J. Orth.* 2:11, 661-667, (Nov.) 1916.
60. Robinson, R.D.: Further Experiences with the .020 inch Arch Wire. *Int. J. Orthod.*, 4:3, P.87-91 (March) 1918.
61. Rocky Mountain Dental Products Co. Data. Elgiloy, Cobalt Nickel Alloy, Orthodontic Wires. Denver, Colorado 80201.
62. Rudolph Gunz & Co. Ltd. A. Bushner, Personal Communication. 63-67 Ann St., Darlinghurst, Sydney. Australia.
63. Salmon, E.H.: *Materials and Structures*. London. Longmans, Green and Co. Ltd., 1. 1960. 638 (P.1-18).
64. *ibid* (P.436).
65. *ibid* (P.442).
66. *ibid* (P.515-527).
67. *ibid* (P.274).
68. *ibid* (P.49-110).
69. Shell, J.S.: Stiffness Characteristics and Bending Tests as applied to Dental Materials *J. Am. Dent. Ass.* 232-238 (February) 1940.
70. Smith, R., Storey, E.: The Importance of Force in Orthodontics. The Design of Cuspid Retraction Springs. *The Aust. J. of Dent.*, 56, 11-18, (Dec.) 1952.
71. Storey, E., Smith R.: Force in Orthodontics and its Relation to Tooth Movement. *The Aust. J. of Dent.*, 56, 11-18, (Feb.) 1952.
72. Standards Association of Australia. Australian Standard T.32 — 1965. Resilient Orthodontic Wires.
73. Timoshenko, S., Goodier, J.V.: *Theory of Elasticity*. Tokyo, Kogakusha Company 2nd ed., 1951 (P.33).
74. Tinius Olsen 6 Inch-Pound Capacity Stiffness Testing Machine. Instruction Manual. Tinius Olsen Testing Machine Coy., Willow Grove, Penn. 19090. U.S.A.
75. Tweed, C.: The Application of the Principles of the Edgewise Arch in the Treatment of Malocclusion. *Angle Orthod.*, 9:1. P.12-67 (Jan.) 1941.
76. Unitek Corporation. C. Hayden. Personal Communication. Monrovia, California. 1969, 1972.
77. Wahl, A.M.: *Mechanical Springs*. Cleveland, Ohio, Penton Publishing Co., 1st ed., 1944, 435 (P.399-412).
78. Weinberger, B.W.: *An Introduction to the History of Dentistry*. Vol.1, St. Louis Mosby Co., 1948 (P.75);

79. *ibid* (P.76)
80. Wilkinson, J.V.: Effects of High Temperature on Stainless Steel Orthodontic Archwire. *Aust. Dent. Jour*, 5:5, 264-268 (Oct.) 1960.
81. Wilkinson, J.V.: Some Metallurgical Aspects of STainless Steel. *Am. J. Orth.*, 48:3, 194-206, (Mar.) 1962.
82. Williams, R.V.: Research in Spring Wires Using Original Methods and Testing Apparatus. *Int. J. Orth.* 9:8, 569-608 (Aug.) 1923.