

STUDIES ON THE STRUCTURE OF ENAMEL, DENTINE AND CEMENTUM

A collection of published work submitted to the Faculty of Dentistry of the University of Sydney for examination for the degree of Doctor of Dental Science.

December, 1972

Keith Simon Lester

LIST OF CONTENTS

ACKNOWLEDGEMENTS	Pages i - ii
INDEX OF PUBLICATIONS	iii - vi
NOTES ON PRESENTATION	vi
AUTHOR'S STATEMENT	vii

INTRODUCTION TO THEME OF PUBLISHED WORK	Pages 1 - 9
---	-------------

PUBLISHED PAPERS (Titles numbered according to Index).

ACKNOWLEDGEMENTS:

I wish to record my unreserved gratitude to my friend and colleague, Dr. Alan Boyde, for introducing me to many aspects of the work described here and for making the larger part of it possible. All the carbon replica work and all the scanning electron microscopy were carried out in his laboratory in the Anatomy Departments, first of London Hospital Medical College, and later of University College London. In this connection, I wish to thank Professor J.Z. Young and Mr. Ron Fearnhead for their encouragement and support.

The transmission electron microscopy of sectional material was carried out in the Anatomy Department of New York Medical College. This work was made possible by Dr. J.A.G. Rhodin and Dr. E.J. Reith and I am indebted to them. I also wish to thank Miss Anne-Marie Lindgren for her kind and expert assistance during this time.

The initial light microscope studies of enamel were made in the Department of Histology and Embryology, University of Sydney. I am very grateful to the head of the department, Professor K.W. Cleland, for this beginning and for his crucial support and guidance.

Associate Professor C.J. Griffin provided valuable advice. I also wish to thank Mr. J. Kerr for his expert technical and photographic assistance.

I am happy to acknowledge the help and advice of many other members of the staffs of the departments mentioned above, and also of the Anatomy Department, Kings College London. Especial acknowledgement to individuals has been made, where possible, in the publications concerned.

INDEX:

1. K.S. Lester: Some Controversies Concerning Enamel Histology.
Aust. dent. J. 9, 82-89, 1964.
2. K.S. Lester: The Hunter-Schreger Bands of Enamel.
J. Anat. (Lond.) 97, 491-492, 1963.
3. K.S. Lester: Some Optical Properties of the Hunter-Schreger Bands.
J. dent. Res. 43, 977, 1964.
4. K.S. Lester: The Variability of the Bands of Schreger.
Aust. dent. J. 10, 217-222, 1965.
5. K.S. Lester: The Bands of Schreger.
J. dent. Res. 44, 1193, 1965.
6. K.S. Lester: The Bands of Schreger: The Role of Reflexion.
Archs. oral Biol. 10, 361-377, 1965.
7. K.S. Lester: Light-Optical Effect Associated with the Decussation of Enamel Prisms.
J. Anat. (Lond.) 100, 925, 1966.
8. K.S. Lester: Interpreting the Reflected-Light Appearance of Enamel in the Dog.
Archs. oral Biol. 13, 343-349, 1968.
9. K.S. Lester and A. Boyde: Carbon Replica Study of Developing Dentine.
J. dent. Res. 46, 126, 1967.
10. K.S. Lester and A. Boyde: Electron Microscopy of Predentinal Surfaces.
Calc. Tiss. Res. 1, 44-54, 1967.

11. A. Boyde and K.S. Lester: Electron Microscopy of Resorbing Surfaces of Dental Hard Tissues.
Z. Zellforsch. 83, 538-548, 1967.
12. K.S. Lester: A Carbon Replica Study of Fractured Dentinal Surfaces.
J. Anat. (Lond.) 100, 924, 1966.
13. A. Boyde and K.S. Lester: An Electron Microscope Study of Fractured Dentinal Surfaces.
Calc. Tiss. Res. 1, 122-136, 1967.
14. K.S. Lester and A. Boyde: Some Observations on the Enamel-Dentine Junction.
J. dent. Res. 46, 1286, 1967.
15. K.S. Lester and A. Boyde: The Question of von Korff Fibres in Mammalian Dentine.
Calc. Tiss. Res. 1, 273-287, 1968.
16. A. Boyde and K.S. Lester: The Fine Structure of the Peritubular Dentine.
J. Anat. (Lond.) 102, 144-145, 1967.
17. K.S. Lester and A. Boyde: The Surface Morphology of Some Crystalline Components of Dentine.
In: "Dentine and Pulp; Their Structure and Reactions:." pp. 197-219, N.B.B. Symons, ed.) Livingstone, Edinburgh, 1968.
18. K.S. Lester and A. Boyde: Surface Electron Microscopy of Caries Crystals in Grossly Carious Teeth.
J. dent. Res. 47, 1005-1006, 1968.
19. K.S. Lester and A. Boyde: Some Preliminary Observations on Caries ("remineralization") Crystals in Enamel and Dentine by Surface Electron Microscopy.
Virchows Arch. Path. Anat. Phys. 344, 196-212, 1968.

20. A. Boyde and K.S. Lester: Scanning Electron Microscopy of Some Components of Caries-Associated Plaque. J. dent. Res. 47, 991, 1968.
21. A. Boyde and K.S. Lester: A Method of Preparing Bacterial Plaque Lining Carious Cavities for Examination by Scanning Electron Microscopy. Archs. oral Biol. 13, 1413-1420, 1968.
22. A. Boyde and K.S. Lester: The Structure and Development of Marsupial Enamel Tubules. Z. Zellforsch. 83, 558-576, 1967.
23. K.S. Lester: Fine Structure of Fibrils and Tubules in Developing Opossum Enamel. In: International Symposium on Tooth Enamel. pp. 62-64. (R.W. Fearnhead and M.V. Stack, eds.) Wright, Bristol, 1970.
24. K.S. Lester: On the Nature of "Fibrils" and Tubules in Developing Enamel of the Opossum, Didelphis Marsupialis. J. Ultrastructure Res. 30, 64-77, 1970.
25. K.S. Lester: Electron Microscope Study of the Incorporation of Epithelial Cells by Developing Dental Cementum. J. Cell Biol. 39, 80a, 1968.
26. K.S. Lester: The Incorporation of Epithelial Cells by Cementum. J. Ultrastructure Res. 27, 63-87, 1969.
27. K.S. Lester: The Unusual Nature of Root Formation in Molar Teeth of the Laboratory Rat. J. Ultrastructure Res. 28, 481-506, 1969.
28. K.S. Lester and A. Boyde: Scanning Electron Microscopy of Developing Roots of Molar Teeth of the Laboratory Rat. J. Ultrastructure Res. 33, 80-94, 1970.

29. K.S. Lester: Molar Root Development in the Laboratory Rat. Endodontic Newsletter (Australian Society of Endodontology) 1/5, 12-18, 1972.
30. A. Boyde and K.S. Lester: Elemental Particles in Bone and Dentine. Calc. Tiss. Res. 10, 256, 1972.
-

Note: The major publications (Papers No. 1, 4, 6, 8, 10, 11, 13, 15, 17, 19, 21, 22, 24, 26, 27, 28 and 29) are presented in reprint form, with the exception of 29 which was not suitable for binding and was retyped. The minor publications are published abstracts of papers read (Papers No. 2, 3, 5, 7, 9, 12, 14, 16, 18, 20, 23 and 25) and a letter to the editor (Paper No. 30). These are presented as typed copies of the original with the exception of 16, 23 & 30. The minor publications are bound so as to precede the relevant major paper for they effectively represent progress reports on work which culminated in that major publication. The papers are not presented in strict chronological order of publication, some liberty having been taken to group them in a more logical way according to subject matter.

STATEMENT:

The following statement is made in accordance with Items 32(1), (2) and (3) of the By-Laws of the University of Sydney governing the award of the degree of Doctor of Dental Science.

- (1) The submitted publications are the work of the listed author or authors. The information contained therein is a direct result of original research by the listed author or authors unless otherwise indicated by appropriate referencing.
- (2) Papers 9-11, 13-22 and 28 are under joint authorship with Dr. Alan Boyde, the work for all of them being carried out in his laboratory. Of these Papers, 9, 10, 11, 16, 20, 21 and 22 were initiated and directed by Dr. Boyde and were conducted jointly. Papers 13, 14, 15, 17, 18, 19 and 28 were initiated and directed by myself and were conducted jointly.
- (3) Paper 1 is an abbreviated extract from a thesis entitled "The Histology of Mature Human Dental Enamel", submitted to the University of Sydney in 1963 in partial fulfilment of the requirements for the degree of Master of Dental Surgery. Papers 2-8 are based on work described in a thesis entitled, "A Study of the Bands of Schreger" and submitted to the University of Sydney in 1965 in partial fulfilment of the requirements for the degree of Doctor of Philosophy in the Faculty of Dentistry.

INTRODUCTION:

This collection of published papers describes research into the morphology of the three, peculiarly dental, hard tissues: enamel, dentine and cementum. The high mineral content, the relative acellularity, and the resultant hardness of these tissues make their study by normal histological methods difficult and sometimes impossible. Herein lies both the dilemma and the challenge. It is for this reason that a variety of microscopical techniques and a variety of methods of specimen preparation must be brought to bear if a true morphological picture is to be obtained.

The first research paper presented here reports a light microscope study of human enamel. The last research paper reports a scanning electron microscope study of developing roots of rat molars. The aim throughout was to investigate the microscopic anatomy of the dental hard tissues. As with much research, the course taken from the first experiment to the last was not, and could not possibly have been, foreseen. In retrospect, three major factors influenced the course of this work: those colleagues (and their ideas) encountered along the way; the accidental; and one's own curiosity and affection for the subject. The introduction provided below is an attempt to formalize these influences and to provide a continuum in which the individual papers may be seen to advantage.

Paper 1:

This paper is an abbreviated critical review of some aspects of enamel histology. The purpose of the original survey was to identify controversial areas in the field of histology which might lend themselves to investigation by means of various optical microscopical techniques. One feature of enamel histology in particular, the bands of Schreger, was found to go by various names, to have been described under various conditions, and to have been ascribed various origins. It was apparent that no concerted attempt had been made to ascertain whether the various bandings coincided or to determine their etiology.

Papers 2-4:

The purpose of this initial project was to examine in a controlled way the range of appearances of the bands of Schreger when a longitudinal ground section of enamel was examined by incident light. The variability in appearance was assessed by rotating a longitudinal ground section of human enamel under a fixed, angulated, incident light source. A reproduceable sequence of changes in appearance was described. The findings indicated the need for a methodical examination of the relationship between the orientation of the constituent enamel rods, the incident light source, and the appearance of the bands of Schreger. It was concluded that only by such examination could an attempt be made to analyse and understand the phenomenon.

Papers 5 and 6:

These Papers report the experiments which demonstrated that groups of parallel enamel rods act essentially as elongated, cylindrical mirrors. This was done by adapting a geological instrument, the Leitz four-axis universal rotating stage, to histological use. The device permits controlled, calibrated rotation for 360° about vertical and inclined vertical axes and for 260° about horizontal axes. The universal stage also allows convenient examination of the same specimen area by transmitted polarized (and ordinary) light and by incident light throughout the range of manipulation of the specimen. In this way, a three-dimensional assessment of crystallite (and thereby of rod) orientation was determined and combined with assessment of rod reflectivity. The individual enamel rods, manifesting en masse the phenomenon of the bands of Schreger, were found to oblige the laws of reflection.

Papers 7 and 8:

As a sequel to Paper 6 above, examination was made of the range of positions, relative to a fixed light source, within which a group of parallel enamel rods remain reflective. By mapping out these zones of reflectivity, explanation was provided for a number of sequences of appearances, or patterns of behaviour, of the bands which were described in previous papers. Finally, assessment of the behaviour

of the bands of Schreger is presented as a means of assessing the sub-surface orientation of enamel rods.

Papers 9-22:

The work reported in Papers 9-22 was carried out in conjunction with Dr. Alan Boyde. In 1965, Dr. Boyde was working on enamel structure and development utilizing, in particular, scanning electron microscopy and a high resolution carbon replica technique for transmission electron microscopy coupled with stereo-photogrammetric analysis. The scanning electron microscope was, at that time, in the early stages of its development as a biological instrument for the three-dimensional sampling of intact mineralized specimens. The carbon replica technique coupled with stereo-photogrammetric analysis affords a unique opportunity of visualizing detailed surface morphology. The combination of these surface techniques provides an ideal means for the examination of mature, mineralised tissues hitherto generally inaccessible to the higher resolution afforded by electron microscopy because of the difficulty of obtaining ultra-thin sections. Organic solvents were used on much of the material in order to remove soft tissue debris, often an unwanted complication of direct viewing techniques. Every one of the Papers 9-22 represents an application of these surface techniques to a particular tissue or area which had not been examined

with such clarity before, viz.,

predentine (9, 10)

resorbing surfaces of enamel, dentine and cementum (11)

fractured dentine surfaces of a wide variety of
mammalian species (12, 13)

the region of von Korff fibres in developing and adult
dentine (14, 15)

some crystalline components of dentine (16, 17)

caries (remineralization) crystals in enamel and
dentine (18, 19)

bacterial plaque lining carious cavities (20, 21)

marsupial enamel (22).

Justification for these studies is found in the original images obtained and the unique visual concept of the subject matter they provide. Individual introductions to the specific problems studied and the application of the results to their solution may be found in the papers themselves.

Papers 23 and 24:

The last of the papers (22) mentioned above, established the much disputed reality of tubules in marsupial enamel and the fact of

their continuity with dentinal tubules across the enamel-dentine junction. Some questions remained unanswered, among them:

- a) Whether or not the tubules contained organic material;
- b) If so, whether this material was intracellular or extracellular; and
- c) The precise nature of the origin of the tubules from the formative cells.

The electron microscope laboratories of Dr. J.A.G. Rhodin and Dr. E. J. Reith provided an ideal situation for examining these problems. Large area, ultra-thin sections of well-fixed developing opossum material were prepared and examined and definitive answers obtained for these questions.

Papers 25-27:

Papers 9 and 10 report, as introduced above, the application of surface techniques to the study of developing dentine. Papers 25-27 began as a continuation of this work using thin sections of developing dentine of rat molars. The emphasis switched to study of root development when it was realised that the usual sequence of events

described for mammalian tooth root formation did not occur for the rat molar. Papers 25 and 26 describe the early phases of cellular cementum formation and the inclusion of epithelial cells by the cementum. Paper 27 examines later phases of cellular cementum formation where the developing edge of the cellular cementum comes to precede that of the dentine and Hertwig's epithelial root sheath is imbedded en masse between the cementum and the dentine.

Paper 28:

It was found during study of the rat molar root that a very complex arrangement of the formative tissues exists at the root apex during the final stages of its formation. It is difficult when working in two dimensions to reconstruct the third, especially when the method of examination involves ultra-thin sectioning of mineralized tissue for transmission electron microscopy. A more direct mode of examination was desirable. To this end, developing rat molars were rendered anorganic and their roots examined directly in the scanning electron microscope. In this way, a project begun with surface techniques and continued by thin sections was returned to the scanning microscope for clarification.

Paper 29:

This paper is a brief summary of the findings on rat molar root development intended for a clinically oriented, endodontic readership. Some of the comparative histological differences between the teeth of rats and of humans are described in order to emphasise the need for care when extrapolating results from one species to another.

The theme throughout this collection of published work is one of general enquiry into the structure of the dental hard tissues: enamel, dentine and cementum. Because of the difficulties inherent in the histological examination of mineralized tissues, advantage must be taken of any assistance Nature provides. It is this writer's belief that a much wider awareness of comparative dental histology would result in a more purposeful use of particular teeth of particular species. Unique experimental systems are available to the researcher in this way and would greatly assist histological endeavour and the wider application of its results.

It is clear from the small exploration described here that a vast and exciting world of comparative dental ultrastructure lies accessible to the newer, high resolution techniques. A morphological banquet awaits the man with the inclination, the time and the armamentarium.

Some controversies concerning enamel histology

K. S. Lester, M.D.S.*

Introduction

The purpose of this review is to present some of the disputed points—both past and present—in the histological study of enamel and thereby to state the problem rather than to attempt the solution.

There is much to suggest the unique nature of enamel. There are no contained parent cells or cell-processes, thus it cannot be defined as a tissue but rather must be described as a "substance".⁽¹⁾ This absence of cells renders the enamel incapable of repairing any deficiency in its structure and is possibly responsible for the fact that enamel alone of all bodily elements, does not undergo post-mortem degeneration.⁽²⁾ Further it is the hardest substance in the body, the calcium salts responsible for its hardness being unavailable to the general metabolic pool.⁽³⁾

Although difficult of complete segregation, the characteristics of enamel in question will be separated as much as possible for the purpose of discussion.

Organic matrix

Until early this century enamel was generally regarded as consisting entirely of calcium salts. Tomes⁽⁴⁾ in 1896 studied elephant enamel and rejected the estimates of von Bibra and Hoppe-Seyler of approximately 3.5 per cent

organic matter because these were made from estimations of the loss of weight after ignition, which Tomes stated was equal to and could be accounted for by the water content, which, of course, was also lost on ignition. More refined techniques⁽⁵⁾ gave strong indications of the presence of an organic matrix but the problem was now one of histological demonstration. Perhaps Miller⁽⁶⁾ was the first to see the organic matrix by drawing nitric acid under a cover slip over a ground section of enamel. He stated however, "I shall not attempt to offer any explanation of these phenomena although the thought suggests itself that we have to do with uncalcified enamel prisms." It was not until 1923 that the organic matrix was in any way accepted and in that year Bodecker⁽⁷⁾ presented to a meeting of the New York section of the International Association of Dental Research the brown, spongy remains of a completely decalcified tooth, the Association lending official recognition to the discovery.

Serial sections of well preserved decalcified organic elements were studied by Malleson⁽⁸⁾ later in the same year as Bodecker's study, but independent of it. He concluded that enamel consisted of: (i) a highly calcified rod and inter-rod substance; (ii) a rod cortex or sheath that remained after decalcification and could be stained with hæmatoxylin.

* Teaching Fellow, Department of Histology and Embryology, University of Sydney.

Received for publication January, 1963.

Revised and resubmitted June, 1963.

(1) The British Medical Dictionary. Ed. Sir Arthur MacNulty. The Caxton Publishing Co., 1961 (p. 490).

(2) Sognnaes, R. F.—Microradiographic observations on demineralization gradients in the pathogenesis of hard-tissue destruction. *Arch. Oral Biol.*, 1: 2, 106-117, 1959.

(3) Sognnaes, R. F.—Microstructure and histochemical characteristics of the mineralized tissues. *Ann. N.Y. Acad. Sci.*, 60: 5, 545-574 (April) 1955.

(4) Tomes, C. S.—On the chemical composition of enamel. *Journ. Physiol. Camb.*, 19: 3, 217-223 (Mar. 6), 1896.

(5) Mummery, J. H.—The microscopic anatomy of the teeth. London: Henry Frowde, Hodder and Stoughton, 1919 (p. 77).

(6) Miller, W. D.—The presence of bacterial plaques on the surface of the teeth, and their significance. *Dent. Cosmos*, 44: 5, 425-446 (May) 1902.

(7) Bodecker, C. F.—A report of further investigations on the organic matrix in human enamel. *Den. Research Jnl.*, 6: 2, 117-130 (June) 1924-26.

(8) Malleson, H. C.—A preliminary note on the structure of human enamel as revealed in decalcified sections. *Brit. Den. Jnl.*, 45: 2, 601-609 (May) 1924.

Little attention was, however, paid to the organic matrix and in 1944 Frisbie, Nuckolls, and Saunders⁽⁹⁾ said: "... with few exceptions only the most casual consideration has been given to the possibility of a continuous matrix being present in the adult structure". The authors recognized throughout completely decalcified sections an organic matrix, that is to say, core, cortex, and inter-rod substance were shown to have an organic basis.

Sognaes⁽¹⁰⁾ commenced a study of the organic elements of the enamel and was able to demonstrate that the histomorphology of enamel can largely be attributed to the pattern of its organic framework. (Fig. 1).

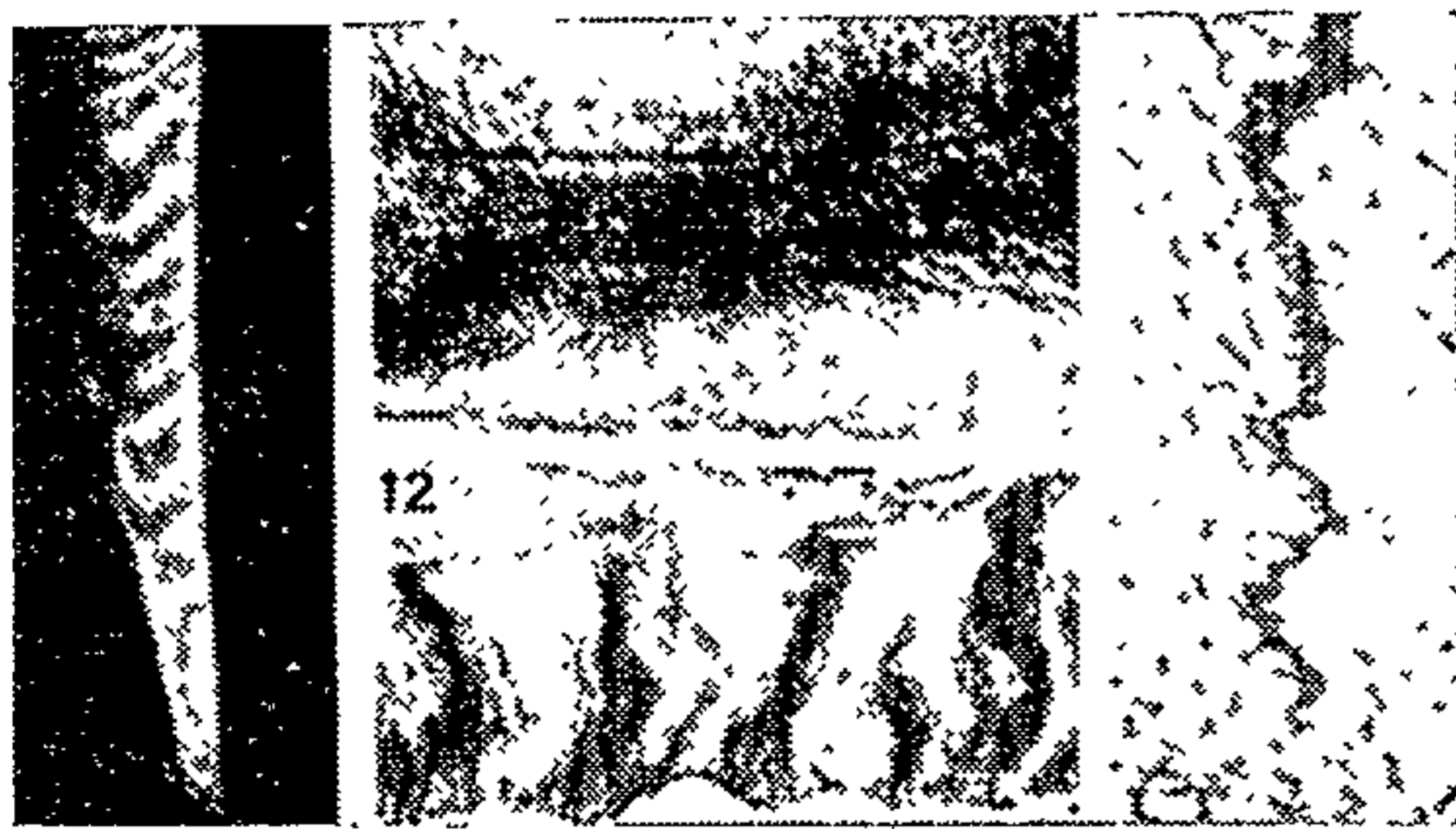

Fig. 1.—Thin decalcified portions of mature human enamel. Left: Hunter-Schreger bands. Top centre: Incremental lines of Retzius. Bottom centre: Enamel tufts. Right: Lamella, showing its independence of the rods. From Figures 10, 11, 12, 13 on page 548 in "Microstructure and histochemical characteristics of the mineralized tissues", by R. F. Sognaes. Ann. N.Y. Acad. Sci., 60: 5, 1955.

Thus, in completely but carefully decalcified teeth, Hunter-Schreger bands, enamel tufts, lamellae and incremental lines may be demonstrated.⁽¹¹⁾⁽¹²⁾⁽¹³⁾

- ⁽⁹⁾ Frisbie, H. E., Nuckolls, J., and Saunders, D. C. M.—Distribution of the organic matrix of the enamel in the human tooth and its relation to the histopathology of caries. *J. Am. Col. Den.*, II: 243-279 (Sept.) 1944.
- ⁽¹⁰⁾ Sognaes, R. F.—The organic elements of the enamel. I. A study of the principal factors involved in the histological preservation of the organic elements of enamel and other highly calcified structures. *J. D. Res.*, 27: 5, 609-622 (Oct.) 1948.
- ⁽¹¹⁾ Sognaes, R. F.—The organic elements of the enamel. II. The organic framework of the internal part of the enamel with special regard to the organic basis for the so-called Tufts and Schreger Bands. *J. D. Res.*, 28: 6, 549-557 (Dec.) 1949.
- ⁽¹²⁾ Sognaes, R. F.—The organic elements of the enamel. III. The pattern of the organic framework in the region of the neonatal and other incremental lines of the enamel. *J. D. Res.*, 28: 6, 558-564 (Dec.) 1949.
- ⁽¹³⁾ Sognaes, R. F.—The organic elements of the enamel. IV. The gross morphology and the histological relationship of the lamellæ to the organic framework of the enamel. *J. D. Res.*, 29: 3, 260-269 (June) 1950.

Electron microscopy of demineralized sections has elucidated the problem further and demonstrated the matrix to consist of sub-microscopic fibrils and these fibrils to be often divisible by characteristic grouping into inter-rod substance, rod sheaths and rods themselves⁽¹⁴⁾⁽¹⁵⁾⁽¹⁶⁾⁽¹⁷⁾⁽¹⁸⁾⁽¹⁹⁾ (Fig 2).

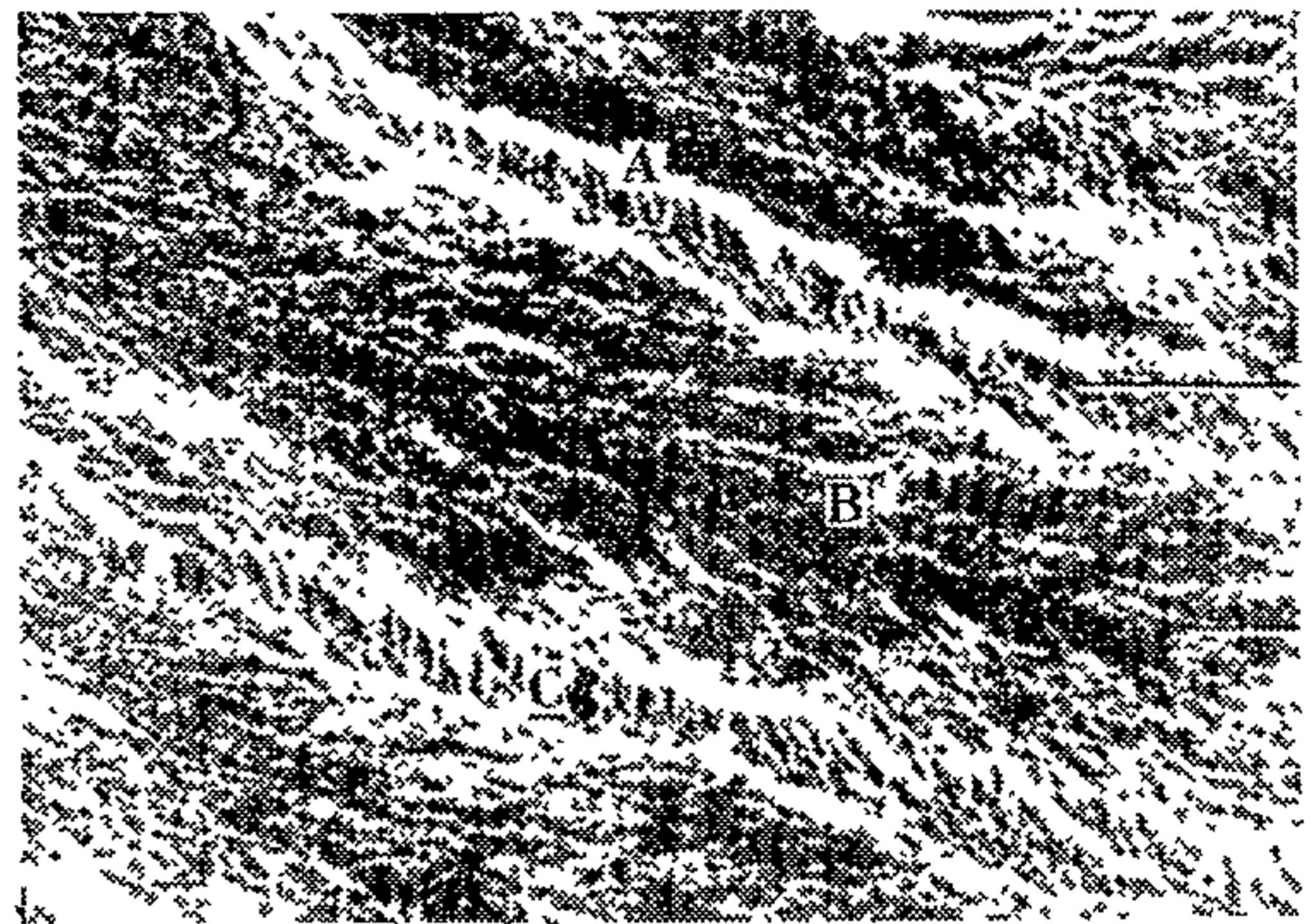

Fig. 2.—Orientation of matrix fibrils (demineralized section). A: rod sheath. B: rod. C: inter-rod substance. $\times 7,000$. From Sicher: *Orban's oral histology and embryology*, 5th ed. St. Louis, The C. V. Mosby Company, 1962. Courtesy Dr. D. B. Scott.

Thus the organic matrix has come to account for many of the histological characteristics of enamel previously ascribed to other factors and to take a prominent position in many theories of the aetiology of caries.⁽²⁰⁾⁽²¹⁾⁽²²⁾⁽²³⁾

- ⁽¹⁴⁾ Bernick, S., Baker, R. F., Rutherford, R. L., and Warren, O.—Electron microscopy of enamel and dentin. *J.A.D.A.*, 45: 6, 689-696 (Dec.) 1952.
- ⁽¹⁵⁾ Scott, D. B., Ussing, Marie J., Sognaes, R. F., and Wyckoff, R. W. G.—Electron microscopy of mature human enamel. *J. D. Res.*, 31: 1, 74-84 (Feb.) 1952.
- ⁽¹⁶⁾ Sognaes, R. F.—Electron microscopy of the enamel of teeth in various stages of development. *J. D. Res.*, 31: 1, 85-93 (Feb.) 1952.
- ⁽¹⁷⁾ Scott, D. B.—The electron microscopy of enamel and dentin. *Ann N.Y. Acad. Sci.*, 60: 5, 575-584 (Apr.) 1955.
- ⁽¹⁸⁾ Quigley, M. B.—Electron microscopy of the amelodentinal junction during early development of the molars of hamsters. *J. D. Res.*, 38: 3, 558-568 (May-June) 1959.
- ⁽¹⁹⁾ Frank, R. M., and Sognaes, R. F.—Electron microscopy of matrix formation and calcification in rat enamel. *Arch. Oral Biol.*, 1: 339-348 (March) 1960.
- ⁽²⁰⁾ Gottlieb, B.—A new concept of the caries problem and its clinical application. *J.A.D.A.*, 31: 1588-1609 (Nov.-Dec.) 1944.
- ⁽²¹⁾ Gottlieb, B.—Dental caries, its etiology, pathology, clinical aspects and prophylaxis. Philadelphia, Lea & Febiger, 1947 (p. 140).
- ⁽²²⁾ Pincus, P.—Production of dental caries—a new hypothesis. *Brit. Med. J.*, 2: 358-362 (Aug. 13) 1949.
- ⁽²³⁾ Martin, J. J., Schatz, A., and Karlson, K. E.—Proteolysis-chelation: a new theory of dental caries. *J. New Jersey D. Soc.*, 27: 7-8 (Comment 6 Nov.) 1955.

The reason for the comparatively late recognition of the organic matrix is now known to lie in the intimacy of the crystal-fibril relationship⁽¹⁹⁾ and the delicacy of the fibrils themselves.⁽¹⁵⁾ Decalcification procedures as applied to bone left no trace of organic structure at all, because the slightest disturbance of the specimen or the decalcifying fluid would disrupt the fragile matrix. To overcome this, immobilization of the specimen during a gentle, slow, decalcification is essential procedure

Enamel rods

Purkinje in 1835 and Retzius in 1837 are credited with the first description of the enamel rods. The shape and course of the rods and their relation to the other structural elements of enamel have been and still are subjects of controversy.

Shape: At first rods were widely held to be hexagonal in shape, hence the term "prism". This resulted from the difficulty of interpretation of ground sections owing to the density and the refractive effects resulting in serious interference with the images. Any deviation from this hexagonal form was attributed to obliquity of the section and the "overlapping" of rods. Two workers, von Ebner⁽²⁴⁾ and Smreker⁽²⁵⁾ first argued against this arrangement and Smreker proposed an arched and grooved rod which interlocked with its neighbours and likened the arrangement to a pavement epithelium. He supported his argument with teased preparations of enamel which he said showed individual rods to be grooved. Study of elephant enamel proved valuable for their argument as it represents an exaggeration of that seen in the human in both form and size, teased preparations showing deeply grooved rods.

These results were reaffirmed by Chase in 1927,⁽²⁶⁾ who for the first time made serial sections of partially decalcified human enamel which he stained with Mallory's connective tissue stain and various hæmatoxylin and eosin combinations (Fig. 3).

⁽²⁴⁾ Von Ebner, V.—Histologie der Zähne mit Einschluss der Histogenese. From Handbuch der Zahnheilkunde, Wien. Ed. J. Scheff, 1909 (p. 240).

⁽²⁵⁾ Smreker, E.—Über die Form der Schmelzprismen menschlicher Zähne und die Kittsubstanz des Schmelzes. Arch. f. Mikr. Anat., 66: 312-333, 1905.

⁽²⁶⁾ Chase, S. W.—The enamel prisms and the interprismatic substance. Anat. Rec., 36: 3, 239-258 (Sep.) 1927.

The nature of the inter-rod substance has given rise to much controversy. Chase⁽²⁷⁾ supported its calcified nature on the basis that: (i) decalcification was necessary before it could be stained; (ii) carbon dioxide bubbles were observed during decalcification from both rods and inter-rod substance.

A recent study⁽²⁸⁾ of extremely thin sections (3-4 μ) of fully calcified enamel by phase-contrast microscopy has left little doubt that: (a) the "fish-scale" appearance is, in fact, a real

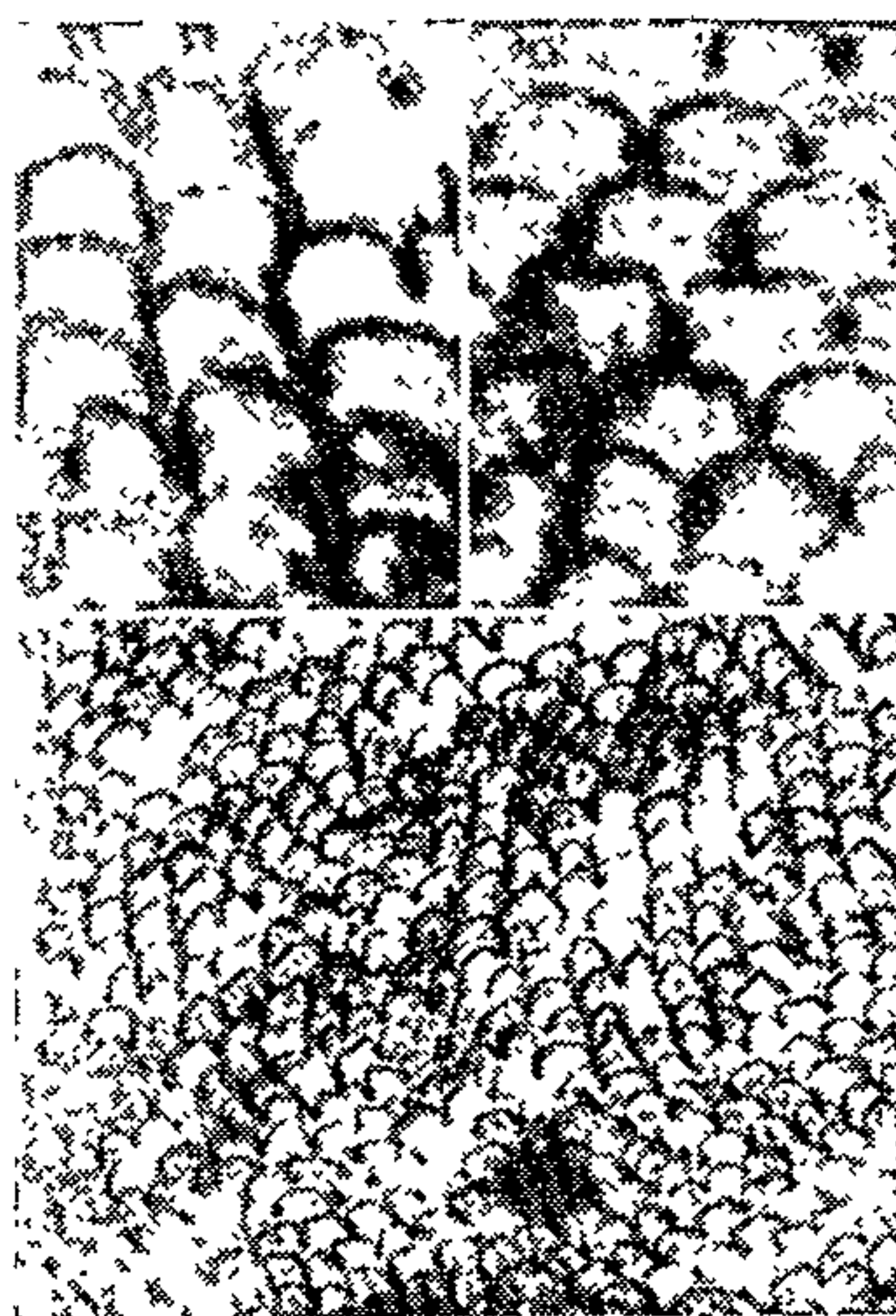

Fig. 3.—Section of partially decalcified adult human enamel cut in a plane perpendicular to the longitudinal axis of the rods and stained with Delafield's hæmatoxylin and eosin. Top: $\times 1,000$. Bottom: $\times 300$. From Figures 3-5, Chase, S. W. Anat. Rec., 36: 3, 245, 1927.

one, and (b) the inter-rod substance is a definite entity, having a different refractive index from that of the rods. The authors contend that because the width of the structure appearing in the place of the rod sheath is exactly the limit of resolution of their apparatus (0.3 μ), then there is no such structure. This opinion seems unjustified, especially in the light of evidence from electron microscopy.

On turning to the findings of electron microscopy in this regard one is met with the following statement: "Instead of leading directly to a clearer understanding of the

⁽²⁷⁾ Chase, S. W.—The origin, structure and duration of Nasmyth's membrane. Anat. Rec., 32: 5, 357-576 (Sep.) 1926.

⁽²⁸⁾ Fremlin, J. H., and Mathieson, J.—Some preliminary observations of dental enamel by phase-contrast microscopy. Brit. D. J., 112: 3, 323-327 (April) 1962.

basic structural elements of enamel and dentine these more detailed findings have increased the difficulty of interpretation"⁽¹⁷⁾ Scott felt that on the generally accepted, although as yet not indisputably proven conceptions that: (i) a single rod is the product of a single ameloblast;⁽²⁰⁾⁽³⁰⁾⁽³¹⁾⁽³²⁾ (ii) rods pass through the full width of enamel,⁽²⁰⁾⁽³³⁾ the rod may be taken as the functional unit of enamel. It is seen as a long filament, roughly hexagonal, round or arcade-shaped in cross section, surrounded by a thin organic sheath and separated from neighbouring rods by varying amounts of inter-rod substance. In a study of 2,000 rods in 500 electron photomicrographs of replicas from thin sections of 185 specimens of enamel only 2 per cent were hexagonal or round with complete sheaths. The remainder, all with incomplete sheaths, were arcade-shaped 57 per cent, polygonal or oval 31 per cent, and very irregular 10 per cent. Thus the rod form most often seen is the arcade or scale-like and has been seen in every type of preparation made: (i) replicas of etched ground sections; (ii) thin sections of demineralized mature enamel; (iii) carious enamel, that is naturally demineralized enamel; (iv) demineralized, immature enamel. This last rules out the dubious explanation still proffered⁽³⁴⁾ that as calcification occurs from one side, the rod hardened first will press into the as yet soft, uncalcified adjacent rod to make it concave.

Even in electron microscopy it has been found difficult to differentiate inter-rod substance, sheath, and intra-rod material. In fact the most common configuration, as yet inexplicable, has been one in which rods appear to have projections between adjacent rods. Another seen often enough to warrant mention is one in which well-defined secondary struc-

tures seem to be present within the rods, that is to say smaller rods may appear contained in larger ones (Fig. 4).*

Size of rods: Another problem of enamel morphology results from the fact that the area at the enamel surface is greater than that at the dentino-enamel junction. The question

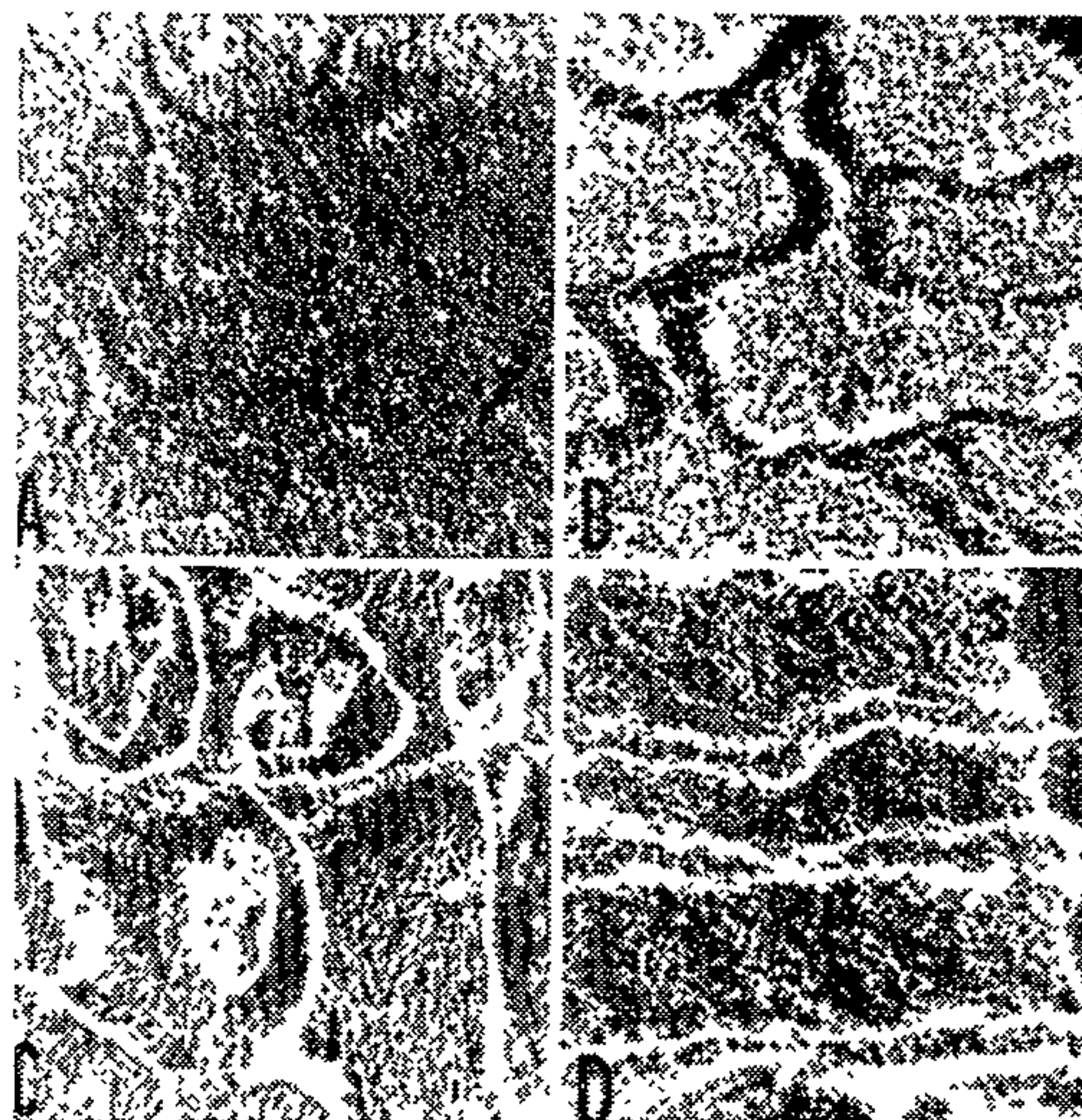

Fig. 4.—Irregular rod outlines in mature enamel observed in replicas of variously prepared enamel sections. A: replica of an etched ground section. B: replica of a thin section of demineralized matrix showing rods appearing to have projections between adjacent rods. C: replica of a thin section of demineralized matrix showing well-defined secondary structures within some of the rods. D: replica of fibrillar matrix in a section of demineralized subsurface enamel (outer enamel surface at S). From Figure 3, page 579 in "The electron microscopy of enamel and dentine", by D. B. Scott. *Ann. N.Y. Acad. Sci.*, 60: 5, 1955.

arises as to how the increase in area is accommodated. If we admit that most of the rods extend through the entire thickness of the enamel, then the following possibilities present: (i) increase in diameter of rods,⁽²⁰⁾⁽³¹⁾⁽³⁵⁾⁽³⁶⁾ (ii) no increase in diameter of rod; but supplementary rods added super-

⁽²⁰⁾ Chase, S. W.—The absence of supplementary prisms in human enamel. *Anat. Rec.*, 28: 1, 79-89 (June) 1924.

⁽³⁰⁾ Chase, S. W.—Development, histology, and physiology of enamel and dentin—their significance to the dental caries process. *J. D. Res.*, 27: 1, 87-92 (Feb.) 1948.

⁽³¹⁾ Hopewell-Smith, A.—Concerning human enamel: facts, explanations and applications. *Dental Cosmos*, 69-4, 360-377 (April) 1927.

⁽³²⁾ Gustafson, A. G.—Morphologic investigation of certain variations in the structure and mineralization of human dental enamel. *Odont. Tskr.*, 67: 361-472, 1959.

⁽³³⁾ Gustafson, G.—The structure of human dental enamel. A histological study by means of incident light, polarized light, phase-contrast microscopy and micro-hardness tests. *Odont. Tskr.*, 53, Suppl. 1945.

⁽³⁴⁾ Orban, B.—Oral histology and embryology. Ed. by H. Sicher, St. Louis, The C. V. Mosby Coy., 4th ed., 1957 (p. 59).

* Recent work suggests, however, that alteration in orientation of crystallites at rod boundaries is the major structural feature responsible for the concept of separate rod, sheath, and inter-rod substance.

Rönholm, E.—The amelogenesis of human teeth as revealed by electron microscopy. II. The development of the enamel crystallites. *J. Ultrastructure Res.*, 6: 3, 249-303 (May) 1962.

⁽³⁵⁾ Land, M., and Gottlieb, B.—The course of the enamel prisms near the cemento-enamel junction. *J. D. Res.*, 23: 1, 39-43 (Feb.) 1944.

⁽³⁶⁾ Von Ebner, V.—In A. Koelliker's *Handbuch der Gewebelehre des Menschen*. Leipzig, Wilhelm Engelmann, 1902 (p. 87).

ficially,^{(30) (37) (38) (39)} (ii) slight increase in diameter of rods but supplementary rods added superficially,⁽⁴⁰⁾ (iv) rods not at right angles at outer surface,^{(32) (41)} (v) increase in inter-rod substance—this last being an unlikely possibility for the inter-rod substance has been noted as more abundant about the dentine cusps.⁽³³⁾

It is generally accepted now that there is an increase in the size of the rods as they proceed externally and that this alone is sufficient to account for any increase in area.⁽³⁴⁾ This followed the work of Chase⁽²⁹⁾ who, examining thin cross sections, measured rod diameter at the dentino-enamel junction and at the surface and who measured also the perimeter of the dentino-enamel junction and the enamel surface. He found the increases in the two to coincide being roughly 1:1.3.

Three factors warrant careful reassessment of this and other similar work: (i) the variability of the results; (ii) the fact that all estimates of the difference in area between the two surfaces have been gained in two dimensions only, and (iii) the likelihood that the increase in prism width is not constant in different areas of the crown. This last is because the increase in area of the enamel surface over the dentino-enamel junction is not constant in different areas, for example, the relative discrepancy would be greater occlusally than cervically. Thus the statement in Orban's text⁽³⁴⁾ that rods increase in diameter by 50 per cent from dentino-enamel junction to surface, would appear unwarranted.

The reason for suspecting the presence of supplementary rods at all was their apparent demonstration by Mummery⁽⁵⁾ in the molar of the wart-hog. While in his published photo-micrograph (Fig. 5) one can see without any doubt two rods, previously running together, separate and a third rod appear between them, the possibility remains that this rod

rather than originating there actually proceeded from a different plane of section than that at which the photo-micrograph was taken.⁽³⁹⁾ Again there is the question of origin of any such supplementary rods and here, at least three possibilities present: (i) the proliferation of ameloblasts, but no mitotic figures can be found after the ameloblasts have commenced matrix deposition;⁽³⁵⁾ (ii) the recruitment of stratum intermedium cells to form ameloblasts⁽⁴²⁾ but this has not been proved

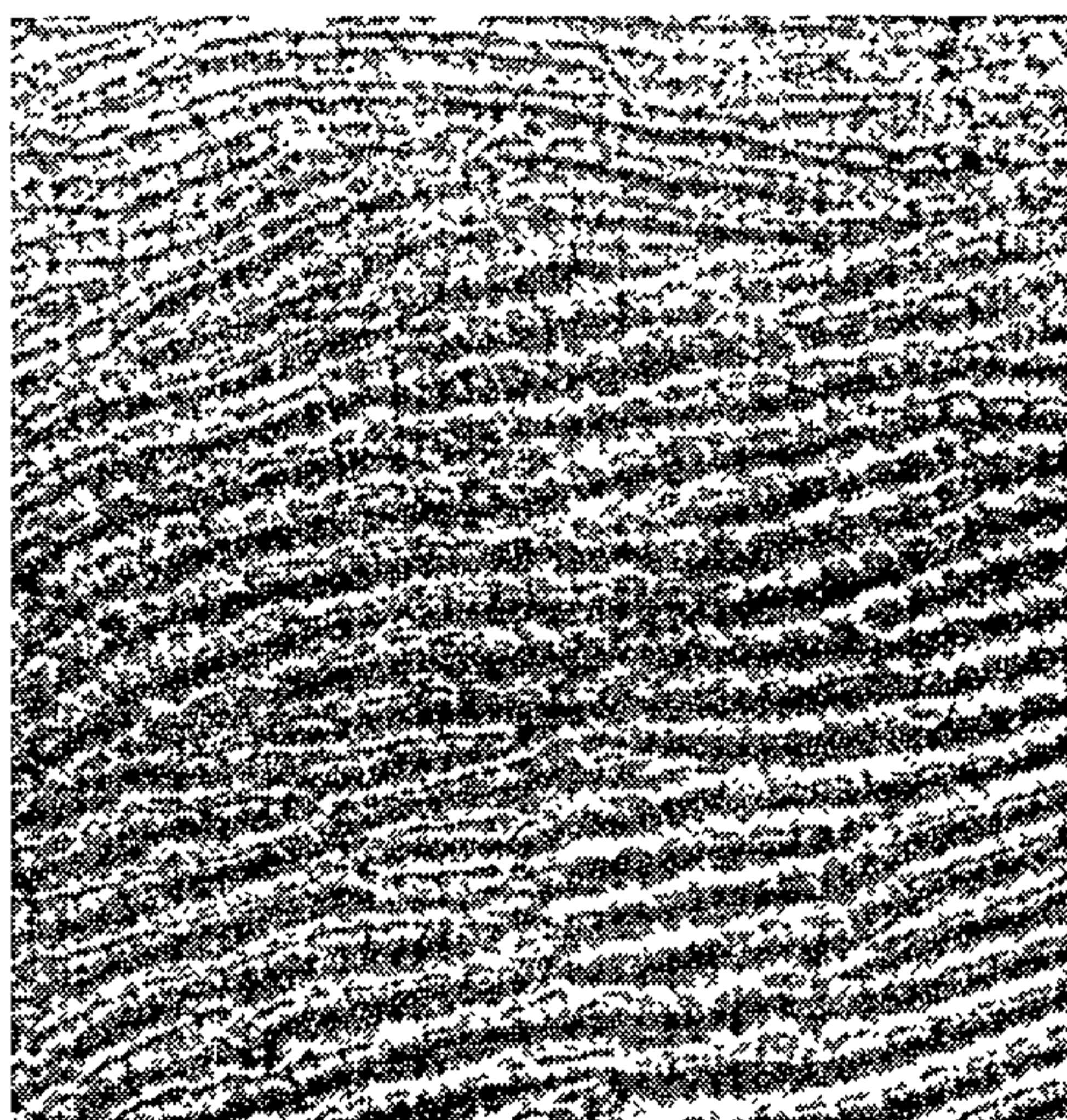

Fig. 5.—Ground section of enamel of Phacoceerus (wart-hog) purporting to show supplementary enamel rods. From Figure 17, Mummery, J. H., "The microscopic anatomy of the teeth". London, Hodder and Stoughton, 1919.

conclusively; (iii) individual rods are not the product of one ameloblast but rather "crystallization products of the homogeneous matrix".⁽¹⁹⁾

Before leaving the problem of rod morphology, three points of difference between rat incisor enamel and human enamel are worthy of note. In rat incisor enamel: (i) the rods, at least in the inner layer, branch;⁽¹⁹⁾ (ii) there seems to be no increase in rod diameter towards the outer surface;⁽¹⁸⁾ (iii) no rod sheath or inter-rod substance can be differentiated in mature adult structure.⁽⁴³⁾ In these it would seem to differ, on present knowledge at least, from human enamel.

⁽³⁷⁾ Tomes, J.—On the structure of the dental tissues of the order Rodentia. Phil. Trans. Roy. Soc. Part ii, 529-562, 1850.

⁽³⁸⁾ Broomell, I. N.—Anatomy and histology of the mouth and teeth. Philadelphia, P. Blakiston's Son & Co., 2nd ed., 1902 (p. 395).

⁽³⁹⁾ Williams, J. L.—Disputed points and unsolved problems in the normal and pathological histology of enamel. Den. Research Jnl., 5: 27-107, Dics. 107-116) (Sep.) 1923.

⁽⁴⁰⁾ Lewis, F. T., and Stohr, P.—A textbook of histology arranged upon an embryological basis. Philadelphia, P. Blakiston's Son & Co., 2nd ed., 1914 (p. 106).

⁽⁴¹⁾ Noyes, F. B.—A textbook of dental histology and embryology. London, Henry Kimpton, 5th ed., 1938 (p. 73).

⁽⁴²⁾ Lehner, J., and Plank, H.—Mollendorff's Handb. d. Mikrosk. Anat. d. Mensch., Vol. 3. Berlin, Julius Springer, 1936 (p. 449).

⁽⁴³⁾ Frank, P. M.—Etude au microscope electronique de l'email humain rapports existant entre le reseau fibrillaire organique et les cristaux d'apatites. Actualites Odontostomat., 13: 13-35, 1959.

The Hunter-Schreger bands

These were first described by Schreger in 1800, although they are said to have been pictured by Hunter in his book "The Natural History of the Human Teeth"—published in 1771.⁽⁴⁴⁾ Although Schreger described them as light bands against a dark background, others described them as dark against a highly reflecting background. They are generally regarded as being seen to best advantage by reflected light in longitudinal sections of enamel, proceeding from the dentino-enamel junction to not quite the outer enamel surface (Fig. 6).

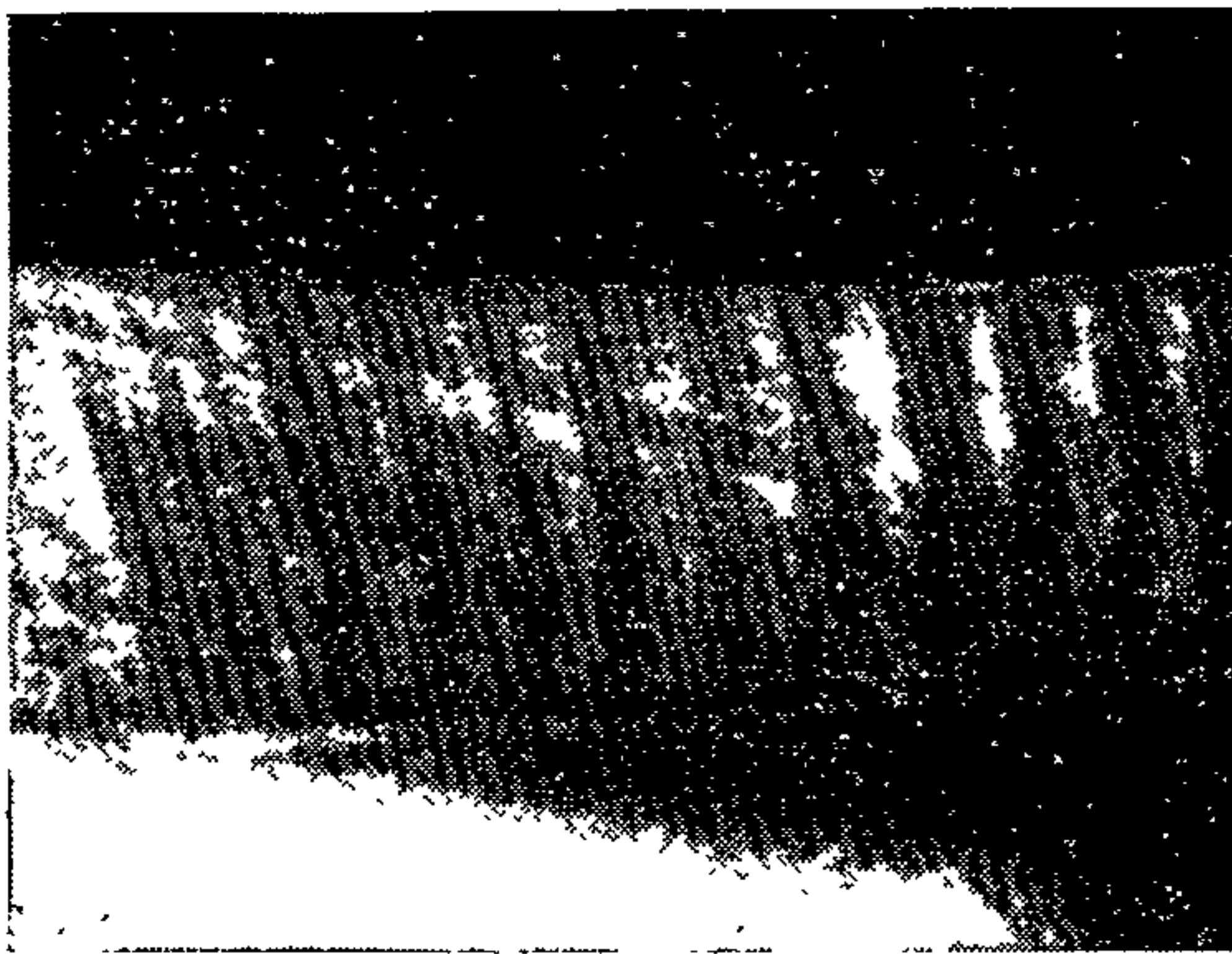

Fig. 6.—Hunter-Schreger bands in longitudinally sectioned enamel as seen by reflected light.

The term "Hunter-Schreger bands" has been applied to alternating bands observed under a confusing variety of conditions: (i) reflected light in fully calcified enamel;⁽⁵⁾⁽⁴⁵⁾ (ii) transmitted light in fully calcified enamel⁽⁵⁾⁽⁴⁵⁾ although others have denied this;⁽⁴⁾⁽³⁶⁾⁽³⁸⁾⁽⁴⁶⁾ (iii) reflected light in fully decalcified enamel⁽¹¹⁾ (see Figure 6); (iv) radiography in fully calcified enamel; (v) replicas of etched enamel—their prominence being proportional to the etching time;⁽⁴⁷⁾ (vi) hæmatoxylin staining of partially decalcified enamel;⁽⁴⁸⁾

(vii) vital staining with hæmolyzed red blood cells;⁽⁴⁹⁾ (viii) dye diffusion in vital and non-vital teeth;⁽²⁷⁾ (ix) transmitted light in developing enamel matrix;⁽⁵⁰⁾ (x) transmitted light in undecalcified developing enamel matrix.⁽⁶⁾ Little effort has been made, however, to ascertain if the Hunter-Schreger bands exhibited by each method actually coincide. The only work known to the author involved⁽⁵¹⁾ the superimposition of two photographs of the bands, one by reflected light, the other by transmitted light, and it was found the bands exhibited by each method did, in fact, coincide.

The ætiology of the bands was not elucidated by Schreger and has remained a subject of controversy.⁽³³⁾⁽³⁵⁾⁽⁴⁵⁾⁽⁵²⁾ Preiswerk (1895) attributed the phenomenon to the bending of groups of rods and this has been the basis for the majority of explanations of the Hunter-Schreger bands,⁽³⁶⁾⁽⁴²⁾⁽⁴⁶⁾⁽⁴⁸⁾⁽⁵³⁾ even though Preiswerk himself, emphatically denied their coincidence.

It is difficult then, to agree with Mummery⁽⁵⁾ that the bands "are evidently due to optical phenomena and have little histological significance". It is considered therefore, that integration of information on these many conditions under which the bands have been reported is necessary before an exact account of the ætiology of the bands can be attempted, and which at this stage would appear to be a subtle combination of rod course, variance in the degree of calcification, and qualitative and quantitative differences in the matrix itself.

Lamellæ

There is less agreement upon this subject than any so far discussed, so little, in fact, that the leader of a symposium of eminent dental histologists on lamellæ⁽⁵⁴⁾ could only conclude that: "This symposium demonstrates

⁽⁴⁴⁾ Hunter, J.—The works of John Hunter (Plates), Palmer, J. F. (Ed.), London, 1837; Longman, Rees, Orme, Brown, Green and Longman (Plate V, Figs. 22, 23).

⁽⁴⁵⁾ Hollander, F., Bodecker, C. F., Applebaum, E., and Saper, Eva—A study of the bands of Schreger by histological and Grenz-ray methods. Dent. Cosmos, 77: 12-20 (Jan.) 1935.

⁽⁴⁶⁾ Widdowson, T. W.—Special or dental anatomy and physiology and dental histology. London, Staples Press Ltd., Vol. 1, Ed. 7, 1939 (p. 165).

⁽⁴⁷⁾ Peyton, F. A., and Mortell, J. F.—Observations of Hunter-Schreger bands. J. D. Res., 35: 804-813 (Oct.) 1956.

⁽⁴⁸⁾ Staz, J.—Bands of Schreger. J. D. Res., 25: 373-380 (Oct.) 1946.

⁽⁴⁹⁾ Forshuvud, S.—A study of the papillary nutrition canals and their possible innervation. Acta Odont. Scandinavica 7, 1, 1946.

⁽⁵⁰⁾ Westin, Gosta—Some details in the histopathology of the enamel. Acta Odont. Scandinavica, 10: 29-62 (June) 1952.

⁽⁵¹⁾ Cleland, K. W.—Personal communication.

⁽⁵²⁾ Lodge, E. B.—A study of the enamel with special reference to the lines of Schreger. Dent. Cosmos, 59: 1087-1092 (Nov.) 1917.

⁽⁵³⁾ Erasquin, J.—The aspect of the bands of Schreger in the horizontal sections of the enamel. J. D. Res., 28: 195-200 (April) 1949.

⁽⁵⁴⁾ Bodecker, C. F.—Enamel lamellæ: a consultant article (Gottlieb, B., Orban, B., Robinson, H. B. G., Schour, I., and Sognnaes, R. F.), Oral Surg., Oral Med., and Oral Path., 4: 787-798 (June) 1951.

a considerable divergence of opinion which in itself may be a contribution on the subject since it indicates a need for research."

Lamellæ can perhaps best be defined as imperfections or discontinuities in the highly calcified arrangement of normal rods, sheaths and inter-rod substance. Such imperfections were first seen by Miller⁽⁶⁾ in 1902 as dark areas in otherwise highly refractile, translucent enamel of ground sections. He called them "Fasern". They were named lamellæ independently by Bödecker⁽⁵⁵⁾ in 1905. Since that time they have been the subject of much controversy. Their significance has ranged from simple enamel⁽²³⁾ fractures, to abnormal malformations⁽⁵⁶⁾⁽⁵⁷⁾⁽⁵⁸⁾⁽⁵⁹⁾ to important, anatomical channels for metabolism⁽⁶⁰⁾ to the central position in one of the theories of the ætiology of caries.⁽²⁰⁾

By careful decalcification and subsequent preservation of the matrix, Sognnaes⁽¹³⁾ was able to eliminate the possibility of cracks formed during grinding of the specimen. The following were his results and the conclusions he drew from them: (i) Organic bands were found in regions where longitudinal cracks could be observed before decalcification. These longitudinal cracks he attributed to trauma. (ii) Organic bands, indistinguishable from those just mentioned were found about silicate fillings, that is to say, where (a) rods are exposed by trauma of cavity preparation, (b) recurrence of caries is known to be low (a characteristic of the filling material), (c) leakage is known to be high (also a characteristic of the filling material). From this he suggested that lamellæ may be a crude form of repair and even a nucleus for future mineralization. The organic matter, he suggested, originated from the saliva. (iii) The lamellæ neither ran a straight course nor followed any one rod or group of rods. Also as no trace of rod structure could be found in the lamellæ it appeared they were not

merely poorly calcified rods. (iv) The lamellæ were not found in unerupted teeth with a frequency which came anywhere near that of the erupted teeth. From this, (iii) and (iv), he concluded that lamellæ were not of developmental origin.

In spite of Sognnaes' dismissal of lamella formation in unerupted teeth, these are of common occurrence.⁽⁶¹⁾ Further, another worker has championed the developmental theory of lamella formation to the virtual exclusion of all else and claimed to have seen in his electron photo-micrographs of lamellæ the faint outlines of rods. Yet only one or two of his series of photo-micrographs are really convincing in this regard. He further claimed that some of the incorporated rods showed evidence of extremely fine needle-like crystals while others showed none. He concluded from this that lamellæ were indeed incompletely calcified rods. However, Awazawa did admit the absence of rods from unusually large lamellæ and also that where lamellæ were extremely thin they consisted of inter-rod substance only, indicative of some other ætiology besides defective calcification of a pre-existing matrix.⁽⁵⁶⁾⁽⁵⁷⁾⁽⁵⁸⁾⁽⁵⁹⁾

The whole complex question of lamellæ would seem one of definition, that definition having to be made with regard to ætiology. There seem to be the following types of lamellæ: (i) A normally existing structure of enamel seen and detected on the enamel surface and continuous from it through a variable thickness running towards the dentino-enamel junction. This type corresponds to Orban's type "A" lamellæ,⁽⁸⁴⁾ and consists of poorly calcified rods and inter-rod substance. (ii) A developmental defect occurring during matrix formation resulting in discontinuity and which can become filled with many types of organisms and cellular debris. This corresponds to Orban's type "B" lamella. The longitudinal orientation of these two types of lamellæ can be explained if, as it would seem, their ætiology lies in ameloblast dysfunction. For if one ameloblast or group of ameloblasts at the cervical loop of the enamel organ becomes affected their progeny, similarly affected, will form beneath them as the cervical loop proceeds towards the future apex of the tooth. (iii) A reaction to trauma consisting of

⁽⁵⁵⁾ Bödecker, C. F.—Preliminary communications upon a new method of decalcifying structures containing minute quantities of organic matter; with special reference to the enamel. *Dent. Review*, 19: 448-455 (Sept.) 1905.

⁽⁵⁶⁾ Awazawa, Y.—Optic and electron microscope observation of the tissue composition of enamel lamella. *J. Nihon Univ. School Den.*, Part 1, 2:1, 23-34 (Sept.) 1959.

⁽⁵⁷⁾ Idem.—Part 2, 2: 2, 91-93 (Dec.) 1959.

⁽⁵⁸⁾ Idem.—Part 3, 2: 2, 99-105 (Dec.) 1959.

⁽⁵⁹⁾ Idem. Part 4, 2: 3, 145-162 (Mar.) 1960.

⁽⁶⁰⁾ Beust, T. B.—Morphology and biology of the enamel tufts, with remarks on their relation to caries. *Amer. Den. Assn. Jnl.*, 19: 488-494 (March) 1932.

⁽⁶¹⁾ Scott, D. B., and Wyckoff, R. W. G.—Shadowed replicas of ground sections through teeth. *Pub. Health Rep.*, 62: 422-425 (Mar. 21) 1947.

unspecified organic material, corresponding to Orban's type "C" lamellae. Why all fractures should be longitudinal is difficult to explain, however. The organic film concerned is said to originate from the saliva. (iv) Elongations of normally existing enamel tufts. These can be differentiated from other types because they run from the dentino-enamel junction outwards through one half to one quarter of the width of the enamel.

Much has been made of the possible predisposition of lamella-affected teeth to caries and of the possibility of the lamellæ forming a prepared pathway for cariogenic agents. In a study⁽⁶¹⁾ of 300 replicas of the surfaces of 300 carious lesions it was found that: (i) half of the cavities involved lamellæ; (ii) half of the cavities were situated between two lamellæ; (iii) lamellæ may cross any part of a carious lesion; (iv) the carious lesion may be situated anywhere between the lamellæ.

It would seem therefore, that from the point of view of inception at least, caries and lamellæ are unrelated—unfortunately no attempt was made to determine the type of lamellæ which were involved in the experiment. On the other hand from the point of view of progression of the lesion many workers feel that caries and lamellæ are intimately related.⁽⁸⁾⁽⁹⁾

Gottlieb⁽⁶⁴⁾ went so far as to describe them as "the main highways for invasion of the tooth", but of course it is realized that the lamellæ themselves are not the complete answer for they are known to occur in the teeth of caries-immune animals—monkey, horse, cow, and rat.

Summary

Organic matrix: The importance of the organic matrix is realized in that it can

account for a great number of the histological characteristics of enamel.

Enamel rods: (a) The idea of regular hexagonal rods with complete sheaths and a definite inter-rod substance is no longer tenable. Instead, the "fish-scale" appearance is seen to be a true one with irregularity of rods, sheaths, and inter-rod substance the rule rather than the exception. (b) Rod dimension is discussed, especially with reference to spatial problems of enamel morphology, and need for careful reassessment of previous work is suggested.

Hunter-Schreger bands: So many investigators, using different material and observing this material under different conditions, have nominated observed bandings as Hunter-Schreger bands that it would be of interest to determine whether these bandings are all identical with those originally described by Schreger. If so, difficulties involving the most commonly proposed theory of their ætiology, based on the section of bands of rods running in alternating directions, would arise.

Lamellæ: The problem appears one of definition and yet such definition must be made with regard to ætiology and structural characteristics about which there is more dissent than any other aspect of enamel histology.

The controversies concerning enamel histology are many and while, no doubt, electron-microscopy of developing and mature human enamel will solve many of these, it would appear that there is scope for further investigations by means of optical microscopy, its modifications and refinements.

Department of Histology and
Embryology,
University of Sydney,
Sydney.

Reprinted from the Journal of Anatomy (Lond.) 97, 491, 1963.

The Hunter-Schreger Bands of Enamel:

K.S. Lester, University of Sydney.

The Hunter-Schreger bands were first described (1800) as alternating light and dark bands in longitudinally sectioned naturally occurring human enamel. They were seen to proceed from the dentino-enamel junction not quite to the outer enamel surface, with a cervical convexity and with the outer end more occlusally or incisally placed than the dentinal end. Since that time the bands have been observed by many other means in variously prepared enamel, little effort being made to ascertain whether the bandings exhibited by the various methods do, in fact, coincide.

This paper describes a surface manifestation of Hunter-Schreger bands and some associated optical phenomena. Various aspects of theories as to their etiology are also discussed.

Reprinted from the Journal of Dental Research, 43, 977, 1964.

Some Optical Properties of the Hunter-Schreger Bands:

K.S. Lester, University of Sydney, Sydney.

Hunter-Schreger bands appear as alternating light and dark areas, generally proceeding from the dentino-enamel junction to not quite the outer enamel surface, when longitudinally sectioned enamel is viewed by incident light. That rotation of the enamel specimen through 180 degrees with respect to a fixed light source results in an interchange of band colour has long been known (Czermak, 1850). The mechanism of change in colour of a band has been found to involve a splitting of a light band with subsequent migration of the segments, the one incisally and the other apically, to effect fusion with similarly separated segments above and below. This fusion allows for formation of light bands in areas previously occupied by dark bands, while the "new" dark bands, which arose in the areas of initial separation of the white bands, have enlarged as the white band segments diverged. A manifestation of Hunter-Schreger banding appearing at the intact outer enamel surface is reported and also seen to exhibit colour reversal on rotation. A partial explanation of band etiology is attempted on the basis of rod course.

The variability of the bands of Schreger

K. S. Lester

Reprinted from the *Australian Dental Journal*, Vol. 10, Number 3, June, 1965, pp. 217-222

The variability of the bands of Schreger

K. S. Lester

Introduction

The classically described bands of Schreger appear as alternating dark and light bands when a longitudinal radial section of naturally occurring enamel is viewed under incident light. Under these conditions the bands commonly extend from the dentino-enamel junction to not quite the outer enamel surface and in so doing, exhibit a convexity towards the cervical end of the tooth (Fig. 1).

There are also, however, bandings at the intact outer enamel surface which may be observed under incident light. These have been suggested as surface manifestations of the bands of Schreger.⁽¹⁾⁽²⁾⁽³⁾⁽⁴⁾⁽⁵⁾ The proportion of human teeth exhibiting these surface bandings to good advantage would appear to be small. This may be the reason for the surface bandings having received little attention.

There is a feature of the classically described bands of Schreger which has often been disregarded although it was described by Czermak at least as early as 1850.⁽¹⁾ The feature referred to is the change in appearance of the bands when the enamel specimen is rotated in a horizontal plane relative to a fixed source of incident light. The net result was described⁽⁶⁾ as occurring after horizontal rotation of 180°, when the light bands resulted in dark bands and vice-versa.

With regard to band appearance during this change there have been described . . . "two

points in the circle where they appear maximum and two where they appear minimum, with maxima and minima at right angles to each other".⁽⁶⁾ That is to say, for reversal to take place there was thought to be a gradual fading from a zero rotation position of maximal band demarcation to a position 90° removed from it of minimal demarcation. At a position 180° removed from the zero position there was again maximal clarity of band configuration but with the bands reversed.

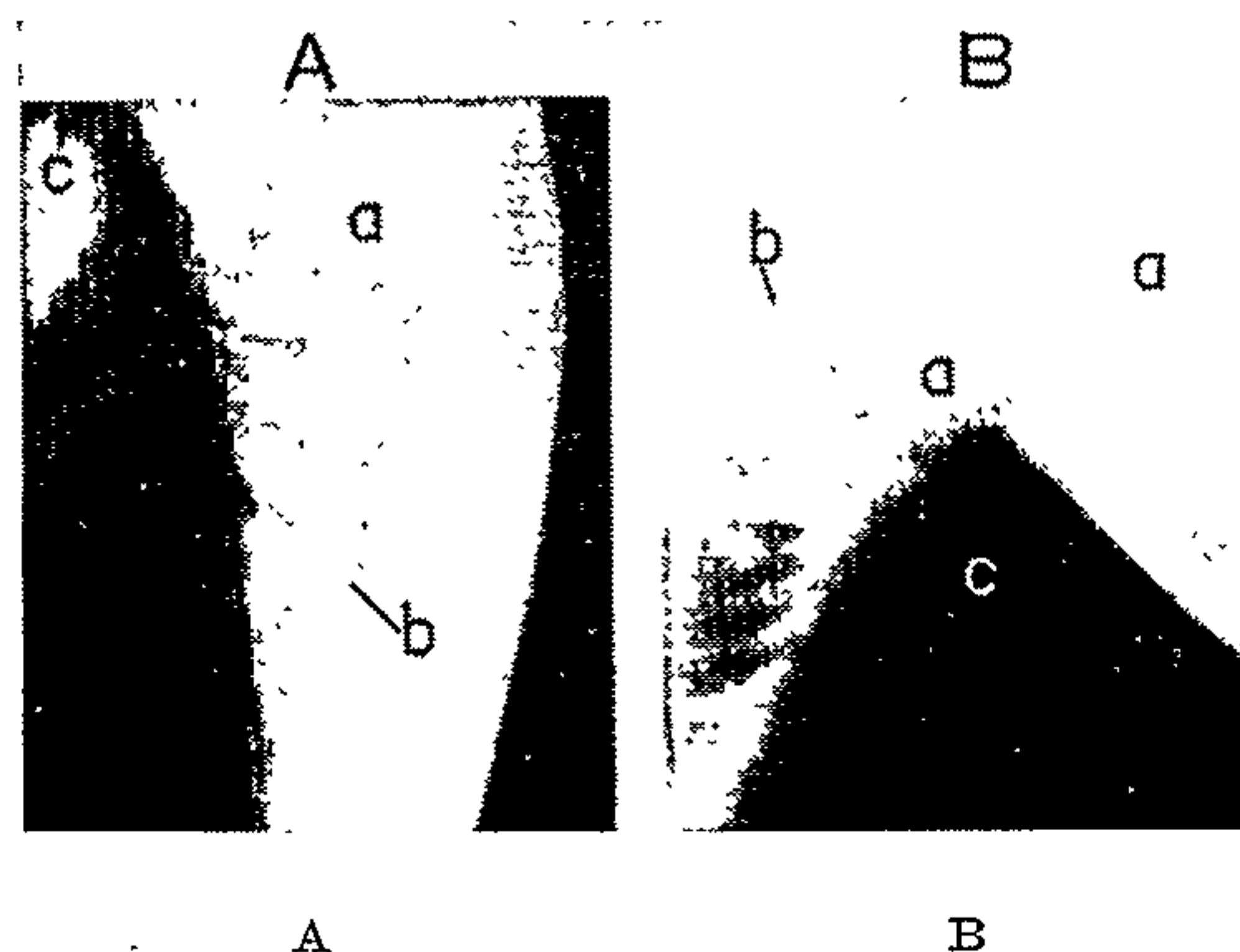

Fig. 1.—Bands of Schreger as observed in a longitudinal radial ground section of a molar by incident light. A: In a lateral plate of enamel, (a) enamel showing typical curved banding; (b) an incremental line of Retzius; (c) a dead tract in the dentine. B: About a dentine cusp, (a) enamel showing a more concentric type of banding; (b) an incremental line of Retzius; (c) dentine. $\times 58$.

One group of investigators⁽⁷⁾ did note however, that in . . . "other instances the individual bands appeared to split in half, thus doubling the number of bands. When this occurred, continued rotation in the same direction resulted in a fusion of contiguous bands".

⁽⁶⁾ Pickerill, H. P.—The structure of enamel. *Dent. Cosmos*, 55: 10, 969-988 (Oct.) 1913.

⁽⁷⁾ Hollander, F., Bodecker, C. F., Applebaum, E., and Saper, Eva—A study of the bands of Schreger by histological and Grenz-ray methods. *Dent. Cosmos*, 77: 1, 12-20 (Jan.) 1935.

Received for publication October, 1964.

⁽¹⁾ Czermak, J. N.—Beitrage zur mikroskopischen Anatomie der menschenliche Zähne. From *Zeitschrift für wissenschaftliche Zoologie*. Ed. by C. Th. von Siebold and A. Kölliker, Leipzig, Wilhelm Engelmann, 1850 (p. 295).

⁽²⁾ Kölliker, A.—A manual of human microscopic anatomy. London, J. W. Parker and Son, 1860 (p. 293).

⁽³⁾ von Ebner, V.—Von den Zähnen. From A. Kölliker's *Handbuch der Gewebelehre des Menschen*. Leipzig, Wilhelm Engelmann, Vol. 3, 1902 (p. 87).

⁽⁴⁾ Preiswerk, G.—Atlas and text-book of dentistry including diseases of the mouth. Philadelphia, W. B. Saunders Co., 1906 (p. 76).

⁽⁵⁾ Pickerill, H. P.—The prevention of dental caries and oral sepsis, London. Baillière, Tindall and Cox, 3rd ed., 1924 (p. 55).

This communication firstly presents, in sequence, some alterations in appearance of the bands of Schreger occurring with rotation of longitudinally sectioned enamel under fixed incident illumination. Secondly, it reports an

produce as small a beam of light as was compatible with the dimensions of the area under observation. The zero rotation position for a specimen was with the incident beam arriving first at the outer enamel edge and

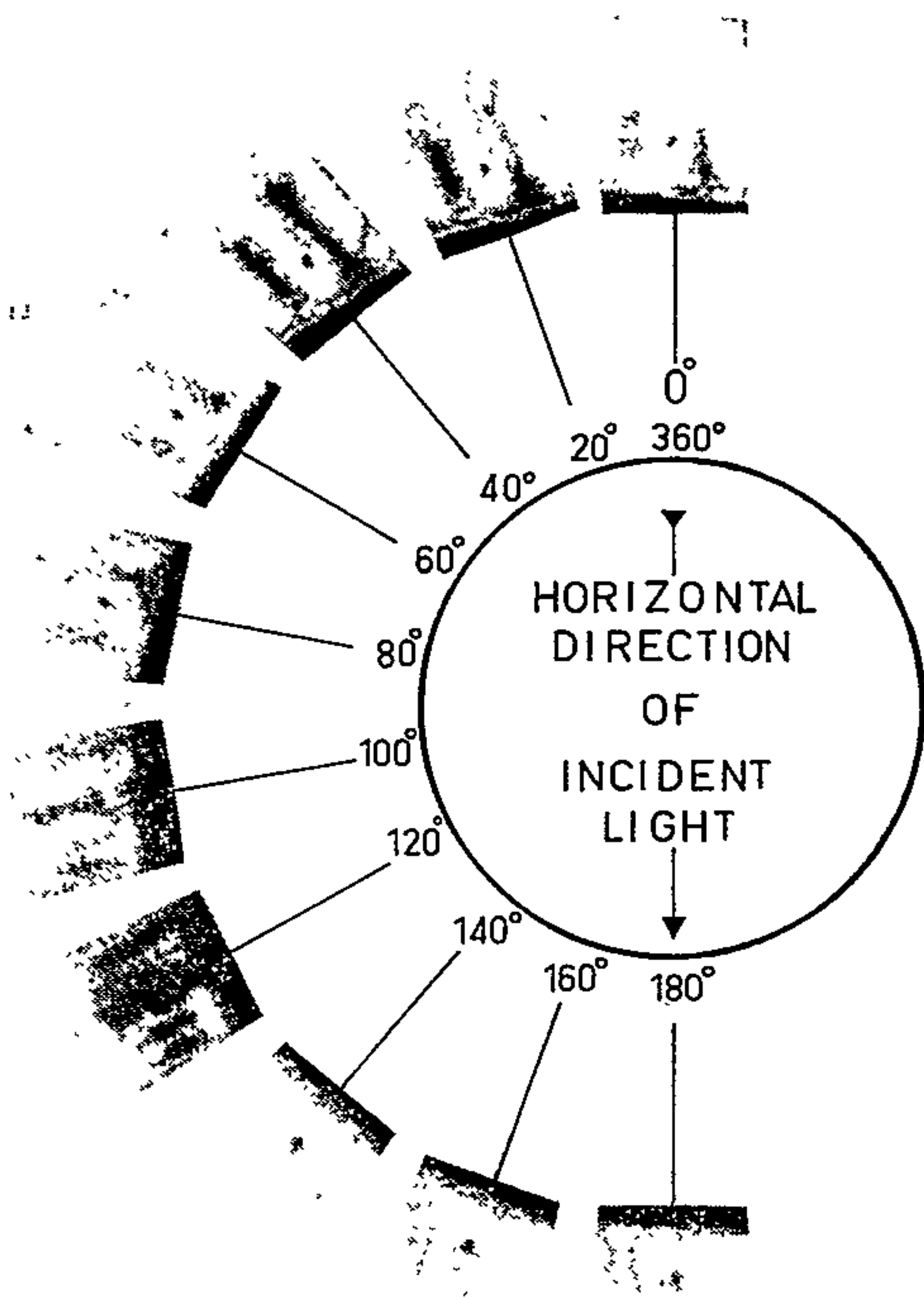

Fig. 2

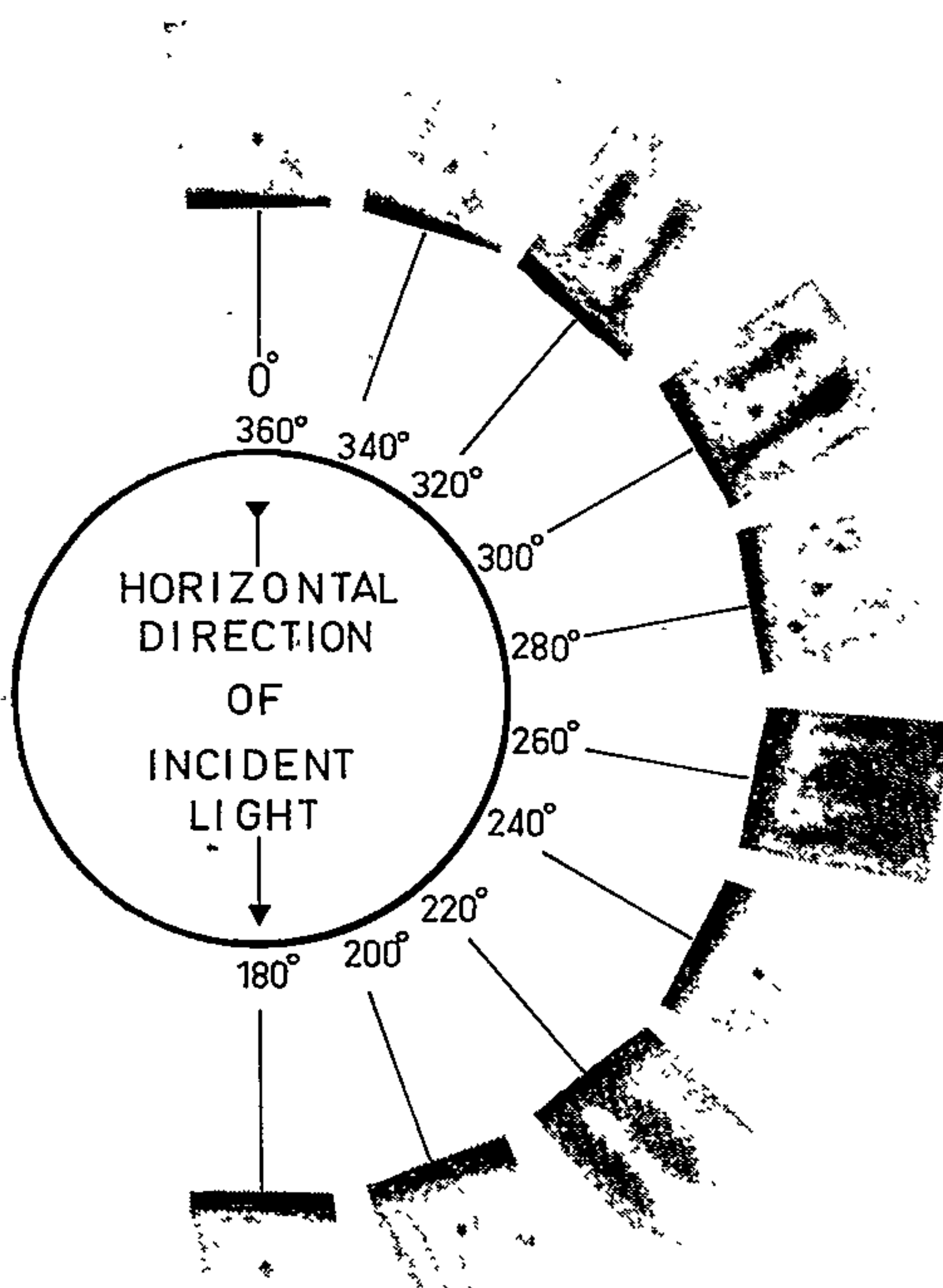

Fig. 3

Figs. 2 and 3.—An enamel specimen upon 360° rotation in a horizontal plane. A particle of carborundum (at arrow) was incorporated beneath the cover-slip for the purpose of localization. Fig. 2: Initial 180° rotation. The major change occurs between the 80° and 100° rotation positions (light to dark). Reversal is complete at the 180° rotation position. Fig. 3: Remaining 180° rotation. The major change occurs between the 260° and 280° positions (dark to light). × 74.

attempt to relate the bands of Schreger to the surface bandings and, to ascertain if reversal is also a feature of the latter.

Method

1. The bands at sectioned surfaces

The examinations were made on the enamel of labio-lingual longitudinal ground sections of human incisors. The sections were 200 microns in thickness.

The necessary incremental rotation was obtained by employing a horizontally rotating microscope stage. The microscope was adapted for use by oblique incident illumination from a Leitz "Monla" microscope lamp. The lamp was placed opposite the observer. The diaphragm of the lamp was adjusted so as to

approximately aligned with the longitudinal axis of the enamel rods.

The following were the procedures carried out:

Specimen A: It was necessary to have some point of reference within the area examined so that accurate comparison could be made of the different appearances presented by that area. Carborundum particles were, therefore, incorporated beneath the coverslip when the specimen was mounted.

The specimen was rotated through 360° in increments of 20°. The appearance of a particular area localized by one of the carborundum particles was recorded photographically after each rotational increment (Figs. 2, 3).

Specimen B: In order to demonstrate more clearly the critical phases of reversal, a specimen was chosen for its well-defined bands rather than for the fortuitous placement of a carborundum particle. Careful centring of the objective with respect to the rotating stage was regarded as providing adequate means of localization. The specimen was rotated slowly but continuously through 360°.

enamel surface and to the newly presented longitudinally sectioned enamel surface, a small groove was made. This groove was to act as a point of reference.

The outer enamel surface and the longitudinally sectioned enamel surface in the region of the groove were photographed. In each case the relationship between the incident light and the specimen was such as to produce

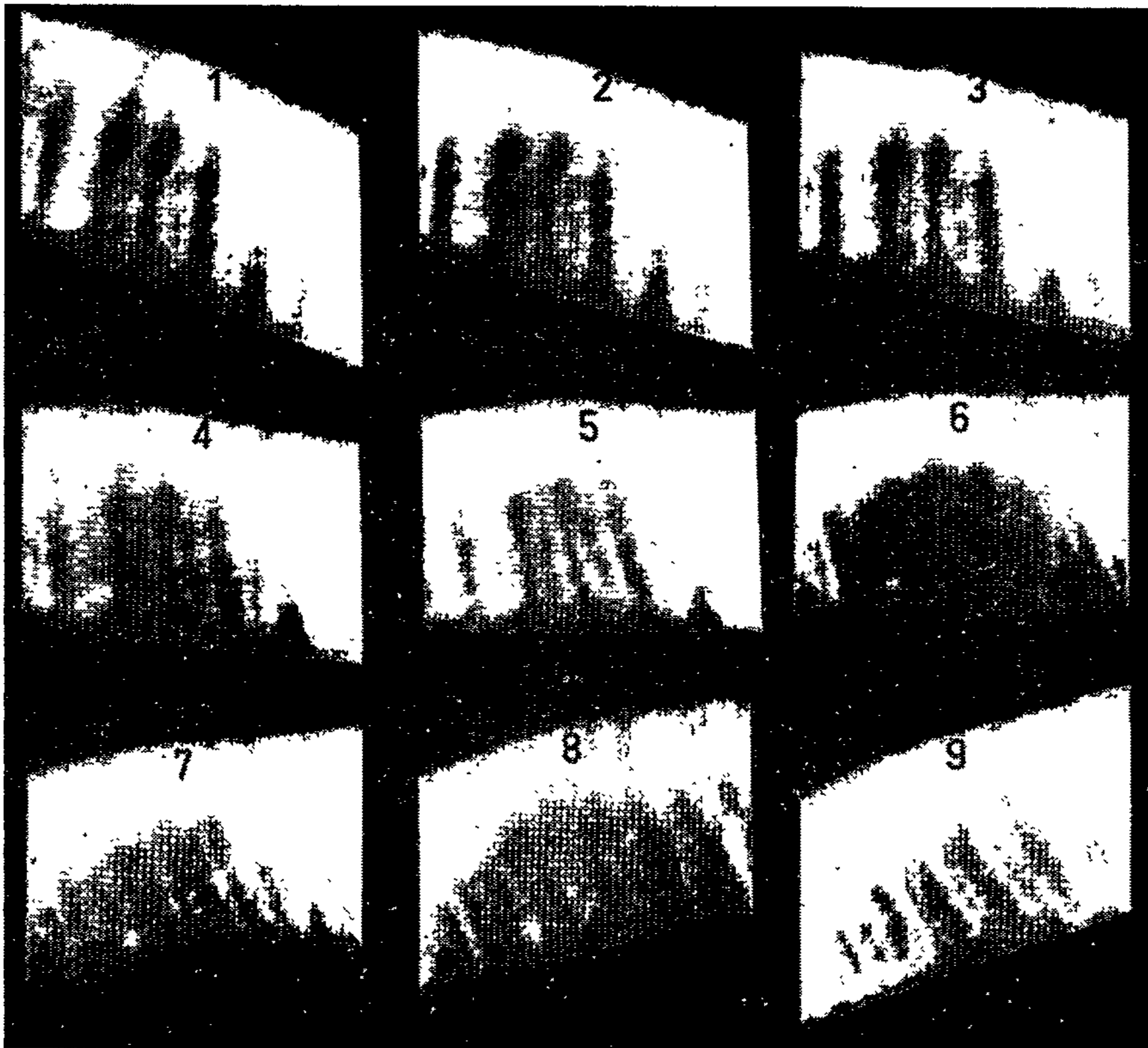

Fig. 4.—An area with well-demarcated bands was rotated from the 60° position (1) to the 100° position (9) in 5° increments. The splitting of light bands, the divergence and subsequent fusion of light band segments is illustrated. The numbers 1-9 have been placed in the same relative position in each print. $\times 80$.

The appearances presented during the rotation from the 60° position to the 100° position were recorded photographically at 5° intervals (Fig. 4: 1-9).

2. The bands at an intact outer surface

(i) A human incisor exhibiting the surface bandings very clearly was sectioned longitudinally along the mid-line in a labio-lingual direction. Subsequent examination was confined to one of the tooth halves so produced. At an edge common to both the intact outer

maximum band demarcation. Comparison of the two surfaces was made by the appropriate apposition of the resulting photomicrographs (Fig. 5).

(ii) A small graphite marking, for the purpose of localization was made in the cervical region of the intact outer enamel surface of another specimen. Under a fixed incident light source, the area about the marking was observed before (Fig. 6) and after rotation of the specimen through 180° within a horizontal plane (Fig. 7).

Results

1. The bands at sectioned surfaces

The appearances observed were as follows. Specimen A (Fig. 2):

(i) When the specimen was in the zero rotation position the carborundum particle was located within a wide light band. On either side of the light band was a thinner dark band.

(ii) The first significant change in the area about the particle occurred at the 80° rotation position. The change was a slight darkening of the underlying light band.

(iii) At the 100° rotation position, the particle was actually situated within a thin dark band. On either side of the thin dark band was a light band apparently split down the centre to include a thin dark band.

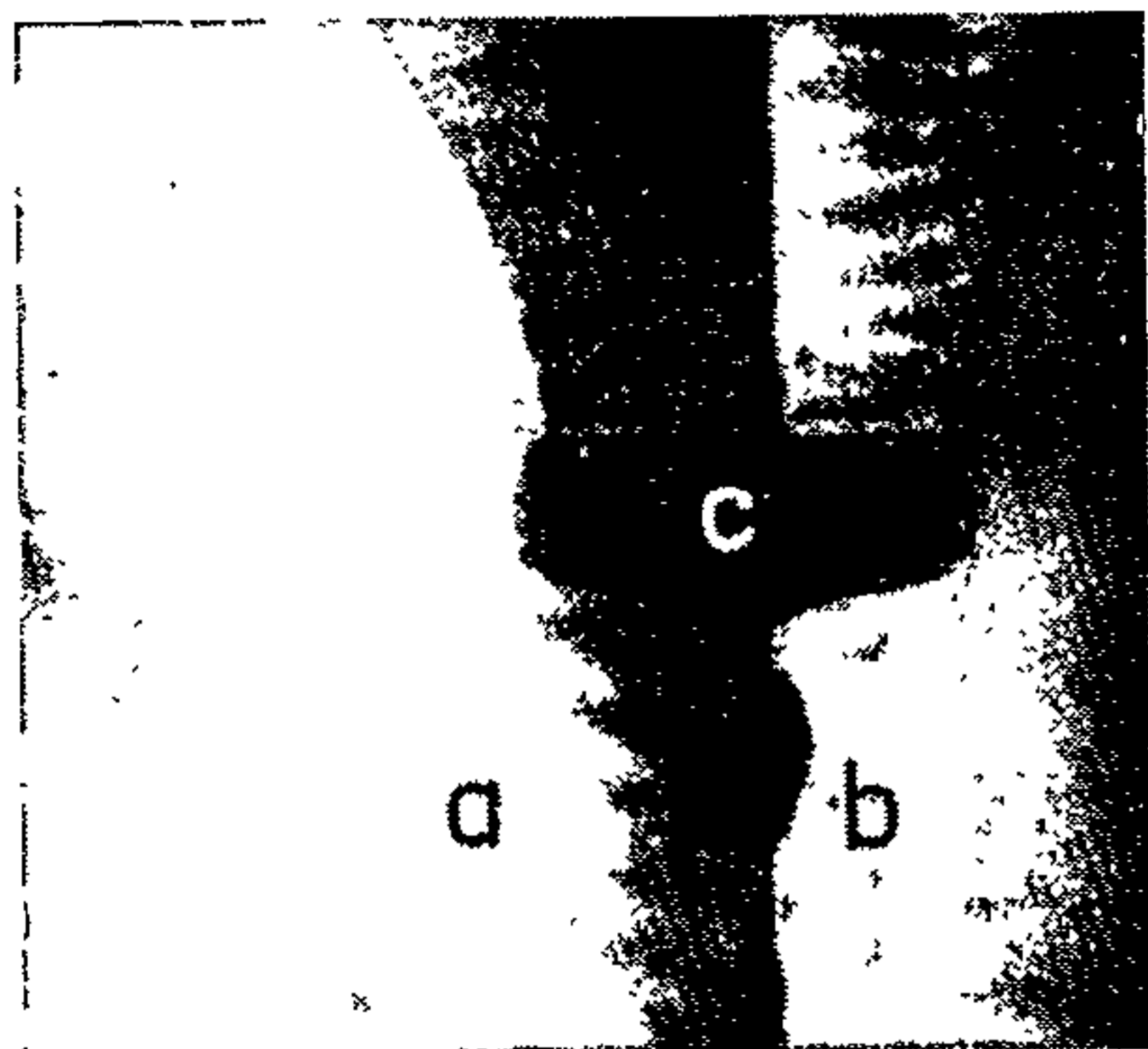

Fig. 5.—Comparison of surface bandings and the bands of Schreger in the same specimen, (a) banding at the intact outer enamel surface; (b) banding at a contiguous longitudinally sectioned enamel surface; (c) localizing groove. $\times 43$.

(iv) At the 140° rotation position, the previously split light bands on either side of the central dark band appeared to be more homogeneous.

(v) Reversal was complete at the 180° rotation position. The carborundum particle was located within a wide dark band, on either side of which was a thinner light band.

The remaining 180° of the rotation presented a similar but reversed sequence (Fig. 3).

Specimen B: The first significant change occurred about the 60° rotation position. There was a splitting of each light band to allow the appearance of a very thin dark band at the site of apparent cleavage (Fig. 4, (1)).

With further rotation there was a parting of the two portions of each split light band

(Figs. 4, (4), (5), and (6)). One of the portions appeared to shift bodily in an incisal direction. The other portion appeared to shift bodily in a cervical direction. As a result, each incisally migrating portion



Fig. 6.—Bandings at the intact outer enamel surface as observed by incident light. The localizing mark appears in the region of a light band. $\times 30$.

approached the cervically migrating portion of a neighbouring split light band (Fig. 4, (7), (8), and (9)). Subsequent fusion of the light band portions occurred to reform a wide light band in the areas previously occupied by a dark band.

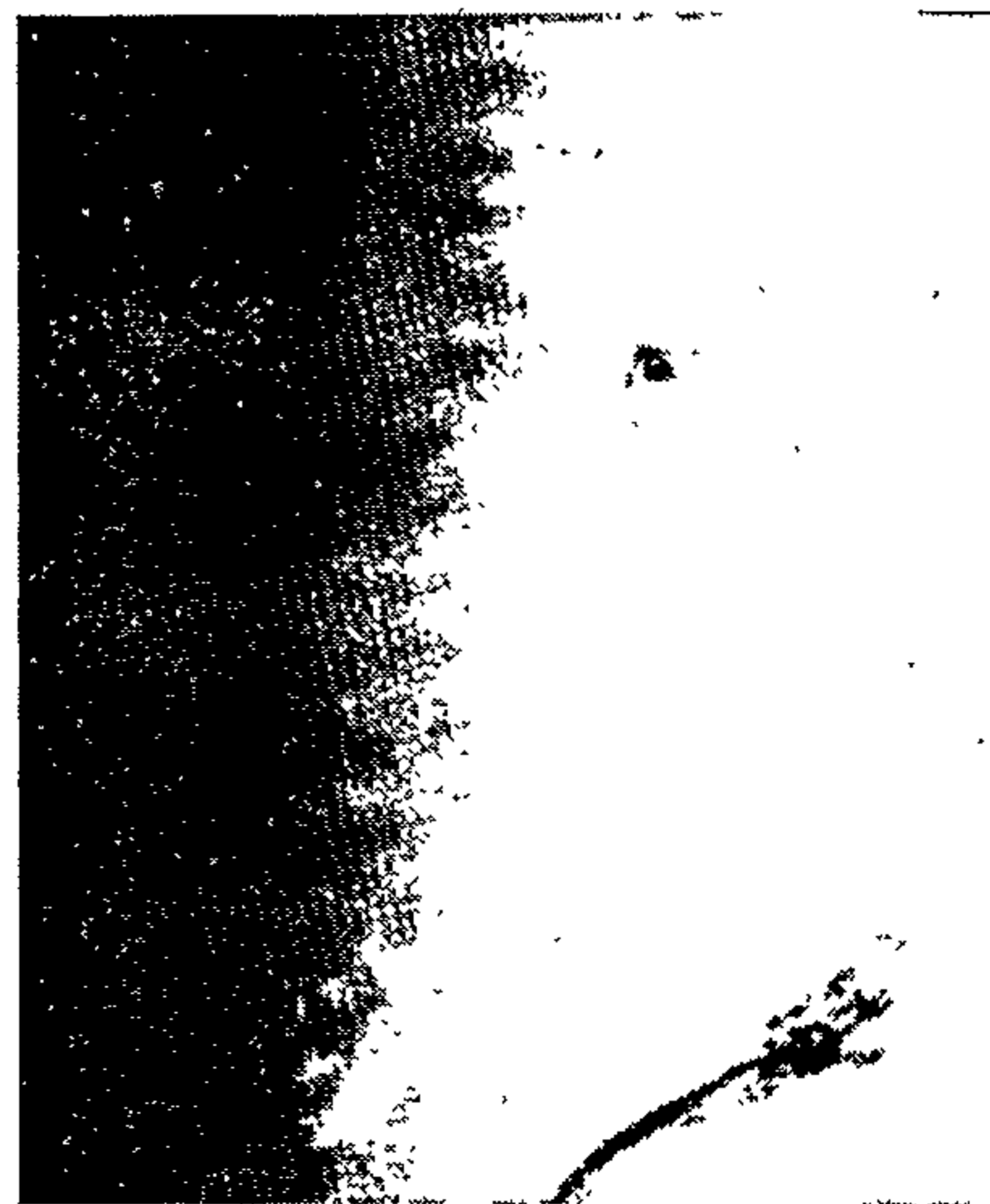

Fig. 7.—The same specimen as in Figure 6 after 180° horizontal rotation relative to a fixed source of incident light. The localizing mark now appears in the region between two light bands. $\times 30$.

Coincident with the apparent migration of the two portions of each original light band away from one another, was an apparent enlargement of the dark band that had arisen at the site of light band cleavage. This enlargement continued until at the 180° rotation

2. *The bands at an intact outer surface*

(i) The bands of Schreger at the longitudinally sectioned surface coincided reasonably with the bandings at the intact outer surface. There was agreement with respect to both shade and dimension (Fig. 5).

(ii) The surface bandings reversed. The graphite marking before rotation of the specimen was located on a light band (Fig. 6). After rotation the marking was located between two light bands (Fig. 7).

Discussion

1. *The bands at sectioned surfaces*

The sequence of band appearances described is, no doubt, that which Hollander *et al.*⁽⁷⁾ briefly referred to as one of two possibilities occurring with specimen rotation.

Some justification can be offered for the more common description⁽¹⁾⁽⁶⁾⁽⁷⁾ of a fading of the bands at the 90° and the 270° rotation positions. Such an apparent sequence can be demonstrated if the examination is made at a lower working magnification and if the means of localization is correspondingly not as definite (Figs. 8 and 9).

It should be emphasized that reversal of bands need not necessarily occur in every area in every specimen upon horizontal rotation. The total sequence here described is only pertinent to complete mutual band reversal.

The vast majority of workers have implicated the tortuosity of rod course as the cause of the bands. Because of the interweaving of rods, there may be found in longitudinal sections of enamel when viewed by transmitted light, areas of predominantly longitudinally sectioned rods alternating with areas of predominantly obliquely or transversely sectioned rods. The actual naming of these areas as "parazones" and "diazones" respectively, is accorded to Preiswerk in 1895.⁽⁷⁾

A number of writers⁽⁷⁾⁽⁸⁾⁽⁹⁾⁽¹⁰⁾⁽¹¹⁾⁽¹²⁾ have subsequently indicated a constant relation of

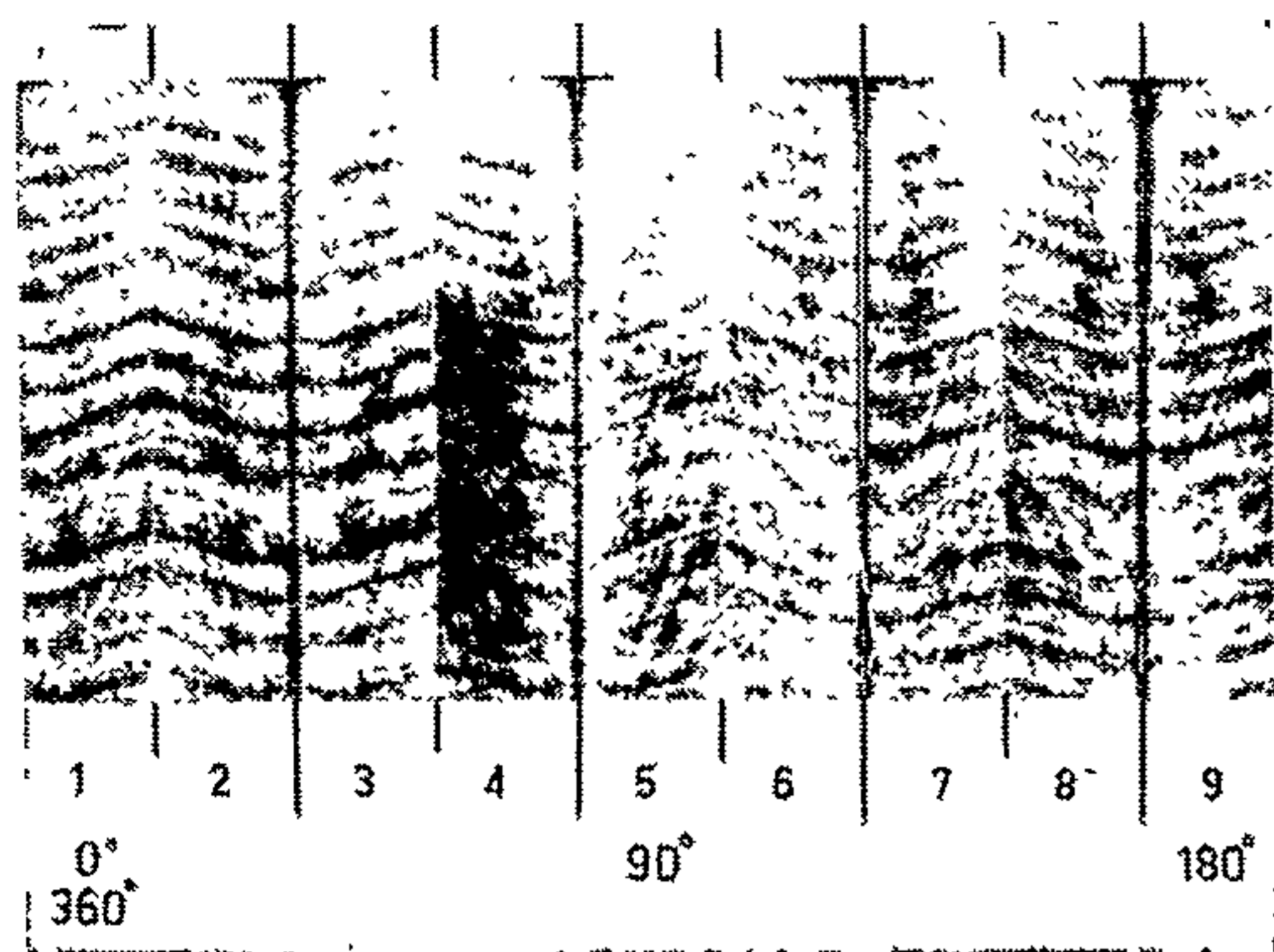

Fig. 8.—Each numbered segment represents the same area, and the specimen was rotated in a horizontal plane through 360° and photographed at each 22.5° of rotation. Each second print has been reversed, so that neighbouring segments may be compared. Rotation through the first 180° x 42.

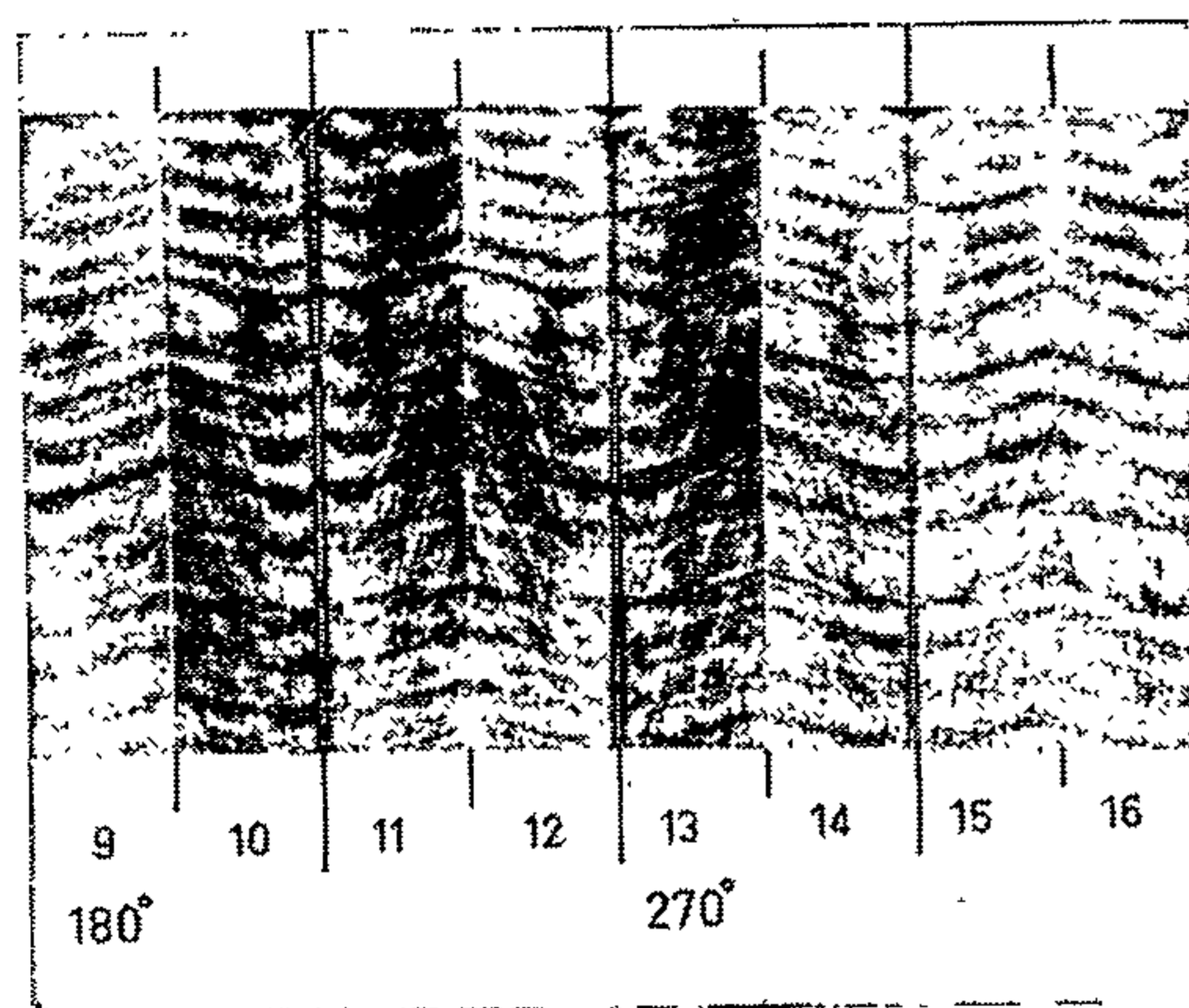

Fig. 9.—Same arrangement as in Fig. 8 with rotation through remaining 180° x 42. Note that in Fig. 8 and 9, the bands appear optimal at positions 1 and 9, and minimal at positions 5 and 13.

position, the dark band filled the area previously occupied by the light band at the zero rotation position..

In the remaining 180° of rotation the sequence of change while similar was reversed, and resulted in the recurrence of the original configuration on the return of the specimen to the zero rotation position.

(8) Churchill, H. R.—In Meyer's histology and histogenesis of the human teeth. Philadelphia, J. B. Lippincott Co., 1935 (p. 23).
 (9) Staz, J.—Bands of Schreger. J. D. Res., 25: 5, 373-380 (Oct.) 1946.
 (10) Erausquin, J.—Aspects of the bands of Schreger in the horizontal sections of the enamel. J. D. Res., 28: 2, 195-200 (Apr.) 1949.
 (11) Widdowson, T. W.—Special or dental anatomy and physiology and dental histology. London, John Bale, Sons and Curnow Ltd., Vol. 1, 8th ed., 1952 (p. 151).
 (12) Manley, E. B., Brain E. B., and Marsland, E. A.—An atlas of dental histology. Oxford, Blackwell Scientific Publications, 2nd ed., 1955 (p. 1).

these "zones" to the bands of Schreger with regard to either width, shade or both. However, a parazone must remain a parazone and a diazone must remain a diazone, regardless of the orientation of the specimen within a horizontal plane. From the variability of the bands described in this paper, it would seem that unless the direction of the incident light to a specimen is specified, any comparison of band appearance with the arrangement of enamel rods in that specimen is of limited value.

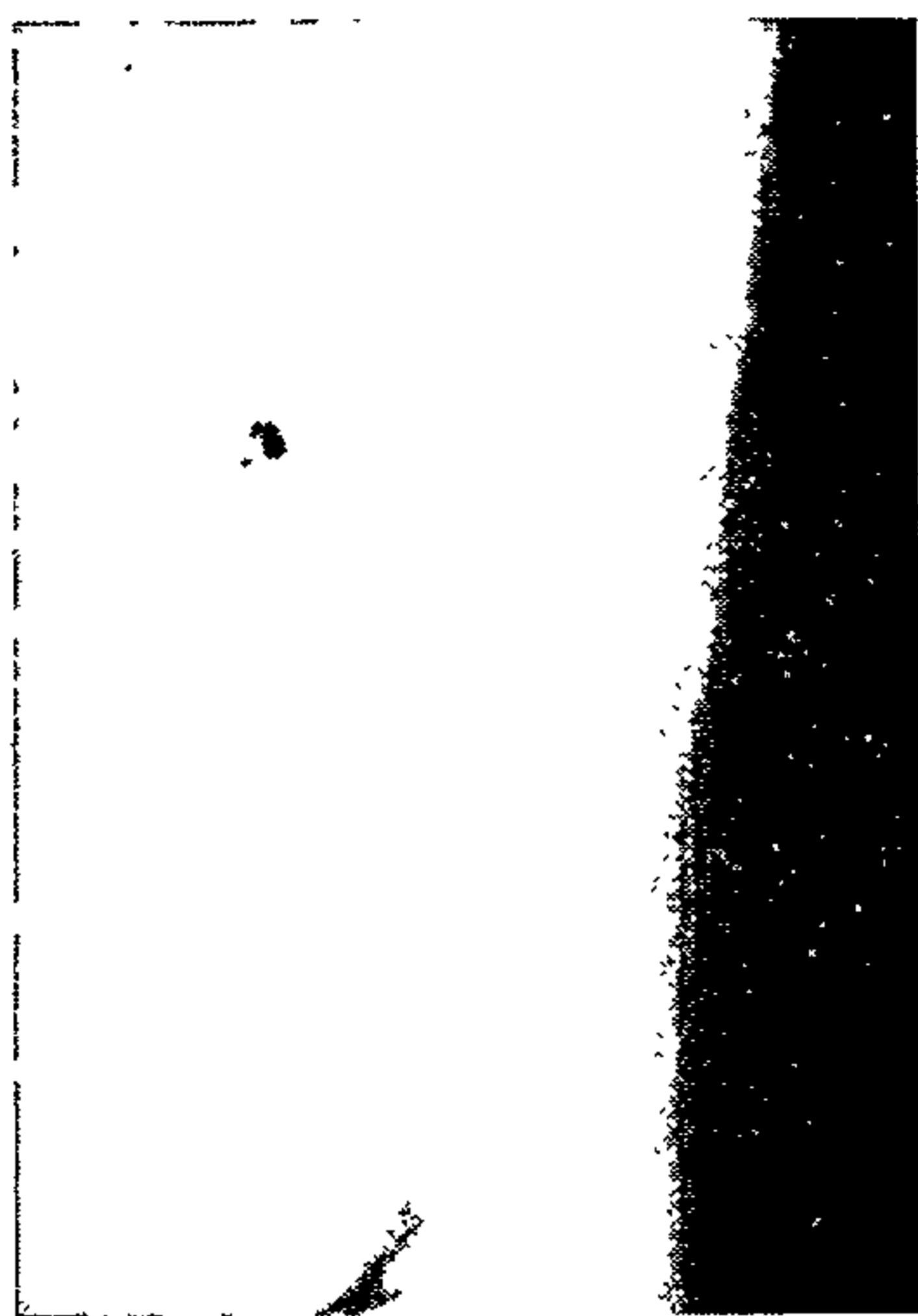

Fig. 10.—The same specimen as in Figures 6 and 7, photographed with the camera focussed not upon the bandings which appear from "within" the enamel, but upon the graphite marking exactly at the outer surface. The bands are not seen. $\times 30$.

2. The bands at an intact outer surface

If the surface bandings and the bands of Schreger were similar phenomena, some variability in the appearance of both would necessarily be implied. The degree of coincidence of the two bandings (Fig. 5) was really therefore, somewhat unexpected.

Reversal of the surface bandings offered further confirmation of their similarity to the

bands of Schreger. However, detailed information with regard to rotational behaviour of the surface bandings was difficult to obtain because of their inherent lack of clarity. This lack of clarity was noted by Czermak⁽¹³⁾ in his original description. He wrote of a pattern which was not superficial but in the thickness of the enamel, as if caused by changes in the deeper structural layers.

The dependence of the surface bandings on the deeper layers of enamel can be illustrated. A photograph of the specimen previously utilized because of its clear surface banding, was taken with the camera focussed on the graphite marking at the surface rather than on a point within the substance of the enamel. The bands were not seen (Fig. 10).

It would seem then, that it is the outer segment of the enamel which detracts from the fullest possible manifestation of the bands of Schreger at the outer enamel surface. The outer segment of enamel also exhibits a lack of band demarcation in longitudinal section. The assumption is⁽¹³⁾ that the rods being parallel, are less likely to exert different effects upon incident light.

Summary

A sequence of varying appearances of the bands of Schreger is presented. The sequence occurred with rotation of longitudinal ground sections (200 microns thick) of enamel under incident illumination. The sequence of appearances would seem to be a constant accompaniment of complete mutual band reversal.

The similarity of certain aspects of banding at the intact outer enamel surface to bands of Schreger at a contiguous longitudinally sectioned enamel surface is demonstrated. Similarity existed with respect to both dimension and the ability to exhibit reversal.

The variability possible in the appearance of the bands of Schreger in any one specimen emphasizes the dependence of their manifestation upon the relationship between the specimen and the incident light.

Department of Histology and
Embryology,
University of Sydney.

⁽¹³⁾ Scott, J. H., and Symons, N. B. B.—Introduction to dental anatomy. Edinburgh and London, E. and S. Livingstone Ltd., 2nd ed., 1958 (p. 147).

Reprinted from the Journal of Dental Research, 44, 1193, 1965.

The Bands of Schreger:

K.S. Lester, University of Sydney, Sydney.

Two thin, ground faciolingual sections of canine dental enamel have been examined with the aid of a four-axis universal rotating stage. One specimen was rotated about both vertical and inclined vertical axes and about horizontal axes under a fixed source of incident light. Each rotation resulted in a different specific sequence of appearances of the bands of Schreger. The second specimen was examined by two means. First, with transmitted polarized light, assessment was made of the inclination to the section surface of the rods in a particular portion of a rod group. Second, under incident light, a number of positions at which this particular portion of rod group was maximally reflective were found. It was possible to demonstrate that the rods appeared as a maximally bright band of Schreger when they were oriented to the incident light, in a manner to satisfy the laws of reflection. The reflectivity of the rods was best explained by regarding them as acting as elongated cylindrical mirrors.

Reprinted from

*ARCHIVES OF
ORAL BIOLOGY*
An International Journal



PERGAMON PRESS

OXFORD · LONDON · NEW YORK · PARIS

THE BANDS OF SCHREGER THE ROLE OF REFLEXION

K. S. LESTER

Department of Histology and Embryology,
University of Sydney,
Sydney, New South Wales, Australia

Summary—Two thin ground bucco-lingual sections of canine dental enamel have been examined with the aid of a four-axis universal rotating stage. One specimen was rotated about both vertical and inclined vertical axes and about horizontal axes under a fixed source of incident light. Each rotation resulted in a different specific sequence of appearances of the bands of Schreger.

The second specimen was examined by two means. Firstly, with transmitted polarized light, assessment was made of the inclination to the section surface of the rods in a particular portion of a rod group. Secondly, under incident light, a number of positions at which this particular portion of rod group was maximally reflective were found. It was possible to demonstrate that the rods appeared as a maximally bright band of Schreger when they were orientated, relative to the incident light, in such a way as to satisfy the laws of reflexion. The reflectivity of the rods was best explained by regarding them as acting as elongated cylindrical mirrors.

INTRODUCTION

MANY descriptions of the bands of Schreger, together with explanations of their possible cause, have been given in the past and these have been reviewed by HOLLANDER *et al.* (1935) and DE BOER and STIEBELING (1958).

The appearance of the bands of Schreger is known to vary when the relationship between a specimen and its incident illumination is altered (CZERMAK, 1850; VON EBNER, 1902; PICKERILL, 1913; HOLLANDER *et al.*, 1935). However, there has been little appreciation of the extent and significance of these changes in band appearance. As a result many writers have attributed the bands of Schreger to characteristics of enamel which imply a constancy of width and shade, incompatible with band variability. For example, the bands have been strictly related to zones of transversely sectioned rods and to zones of longitudinally sectioned rods observed by transmitted light (PICKERILL, 1913; CHURCHILL, 1935; WIDDOWSON, 1946; STAZ, 1946; ERAUSQUIN, 1949; MANLEY, BRAIN and MARS LAND, 1955). It is apparent, however, that the designation of such zones at the surface of a longitudinal section of enamel is unalterable.

The relating of the bands to major differences in the degree of mineralization (HOLLANDER *et al.*, 1935; BERKE, 1936; MORTELL and PEYTON, 1956) is subject to similar criticism. Further, there has been an unfortunate tendency to assume that groups of enamel rods running in differing directions, regardless of the conditions

under which they are observed, are synonymous with the bands of Schreger (SAUNDERS NUCKOLLS and FRISBIE, 1942; SCOTT and WYCKOFF, 1947; YAMAKAWA, 1959; SCHOUR, 1960; AWAZAWA and ONO, 1961).

It was suggested by CZERMAK (1850) that the appearance of the bands was due to the reflexion of light by enamel rods running in differing directions. Although this hypothesis has since been defined more precisely (VON EBNER, 1902; SCOTT and SYMONS, 1952; DE BOER and STIEBELING, 1958), the appearance of the bands has not been related experimentally to the reflexion of light by enamel rods.

This communication presents, firstly, some of the possible variations in band appearance with rotation of the specimen in more than one plane under a fixed beam of incident light. Secondly, it attempts to explain the variability of band appearance by substantiating the role of the enamel rods in reflexion. Assessment of rod orientation necessary to consideration of their possible reflectivity was made by study with transmitted polarized light.

There is known to exist a preferential orientation of enamel crystallites with respect to the enamel rod (CAPE and KITCHIN, 1930; THEWLIS, 1940; LYON and DARLING, 1957; POOLE and BROOKS, 1961; GLAS, 1962). An effect of this preferred crystallite orientation may be seen when an area of enamel containing parallel rods is placed between crossed polars and examined by polarized light. During rotation of the area within the horizontal plane, the parallel rods exhibit birefringence simultaneously.

Maximal bi-refringence, however, can only be exhibited if the mean longitudinal axis of the crystallites is aligned perpendicular to the optical axis of the microscope. Such an alignment of the mean longitudinal axis of the crystallites is made possible by manipulation of the specimen upon a four-axis universal rotating stage. By using this apparatus and by assessing the position of maximal birefringence, the relation of the mean longitudinal crystallite axis to the section surface may be established. While many difficulties arise in the quantitative interpretation of the polarized light picture of enamel (CARLSTRÖM and GLAS, 1962) it is not illogical to interpret birefringence in terms of mean crystallite orientation.

Conveniently, canine enamel differs from human enamel with respect to the preferred crystallite orientation. In canine enamel the mean longitudinal axis of the crystallites is closely coincident with the longitudinal axis of the enamel rod, both in a vertical bucco-lingual or labio-lingual plane and in a transverse mesio-distal plane (CAPE and KITCHIN, 1930). In human enamel, on the other hand, it is common for the axes to agree only in a transverse mesio-distal plane (POOLE and BROOKS, 1961; GLAS, 1962). It follows that in canine enamel definition of the mean longitudinal crystallite axis affords definition also of rod longitudinal axis. Some assessment, then, of rod course in the third dimension is possible.

A short account of the structure of the universal stage follows in order that advantage may later be taken of the abbreviations referring to planes, axes and inclinations.

The Leitz four-axis universal rotating stage (UT4) consists essentially of two turntables (Fig. 1). Each turntable is capable of independent rotation about a vertical axis but is so hinged that each may also rotate independently about a horizontal axis. The orientation of the vertical axis for either

turntable may be altered to become inclined to the optic axis of the microscope. The orientation of the horizontal axis for either turntable may be altered to include any point about the optical axis of the microscope within the horizontal plane. Complete 360° rotation is possible by the turntables about their respective vertical axes. Rotation through an arc of 120° is possible about their respective horizontal axes.

With the apparatus affixed to the horizontally rotating stage of a polarizing microscope, there is described a total of five axes of rotation (Fig. 2). Three of these are vertical axes— A_1 , A_3 and A_5 .

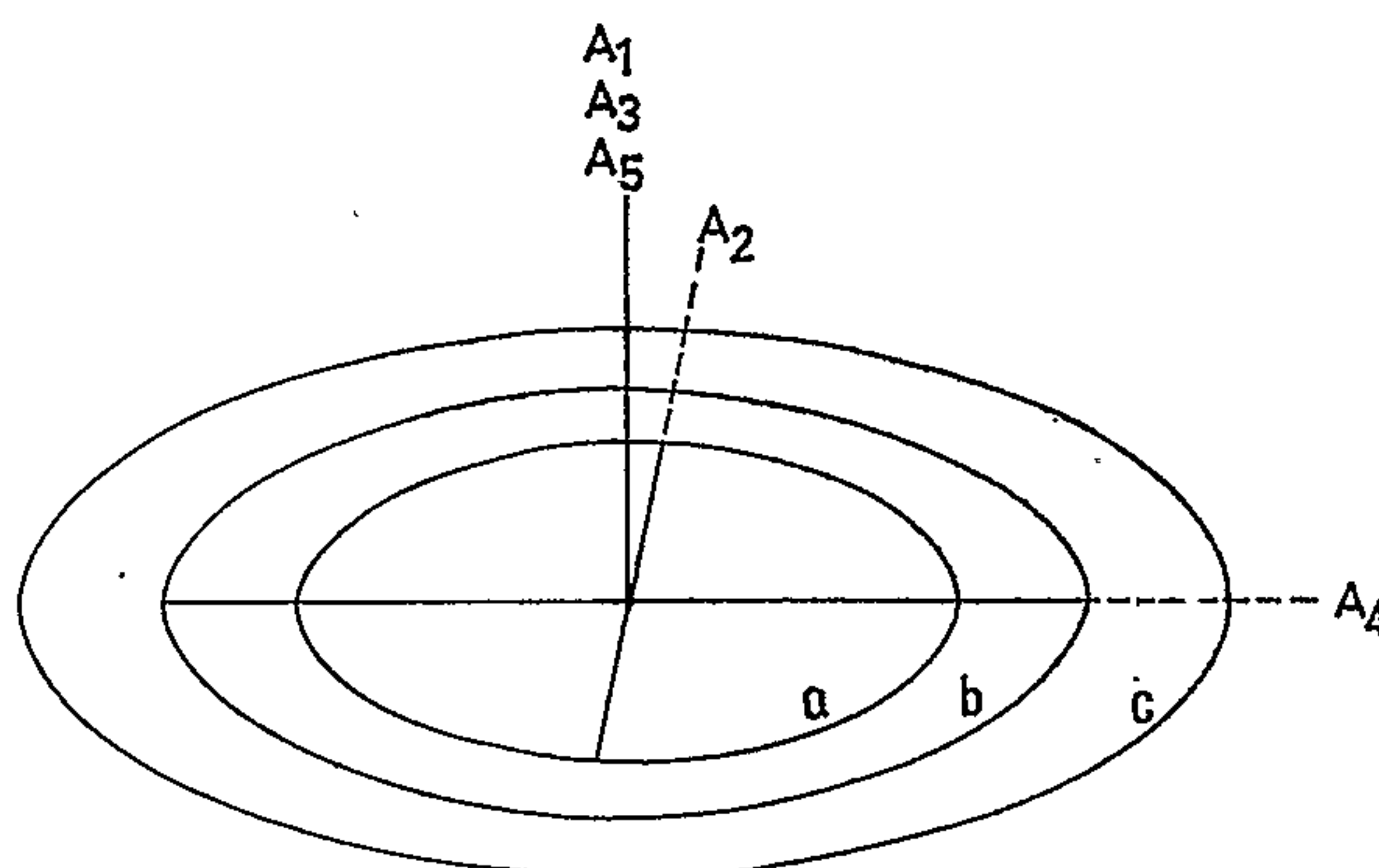

FIG. 2. Diagram of the universal rotating stage affixed to the rotating stage of a polarizing microscope.

- A_1 : vertical axis of inner turntable.
- A_2 : horizontal axis of inner turntable (North-South axis).
- A_3 : vertical axis of outer turntable.
- A_4 : horizontal axis of outer turntable (East-West axis).
- A_5 : vertical axis of microscope stage.
- a. inner turntable of universal stage.
- b. outer turntable of universal stage.
- c. microscope stage.

A_1 is the vertical axis of the inner turntable upon which rests the specimen. A_3 is the vertical axis of the outer turntable. A_5 is the vertical axis of the microscope stage and is non-variable. The two axes remaining are horizontal axes— A_2 and A_4 . A_2 is the horizontal axis of the inner turntable and A_4 that of the outer turntable.

Calibration of rotation is achieved as follows. For rotation about vertical axes, the turntables are graduated in degrees. Each rotates with respect to a fixed point on its individual supporting well. An example— A_3 index = 90° —signifies that the outer turntable of the universal stage has been rotated about its vertical axis A_3 through an angle of 90° .

There is connected to horizontal axis A_4 a graduated drum. Manipulation of the drum effects rotation of the outer turntable about horizontal axis A_4 . Because the outer turntable may in this way come to be inclined towards or away from the observer, a prefix of "red" or "black" respectively is applied. Thus— A_4 index = red 20° —signifies a rotation about horizontal axis A_4 such that the outer turntable becomes inclined towards the observer at an angle of 20° to the horizontal.

For calibration of rotation of the inner turntable about horizontal axis A_2 , two graduated arms are raised from the fixed outer turntable. As the outer edge of the inner turntable passes along either the left or right hand side arm, the angulation made to the horizontal may be read. In this way, — A_2 index = L.H.S. 20° —would signify rotation of the inner turntable about horizontal axis A_2 so that as the observer sees it, the left-hand side of the turntable is raised above the horizontal (the right-hand side, of course, being lowered). The turntable would be inclined at an angle of 20° to the horizontal.

Two factors facilitate consideration of the universal rotating stage in this particular study. Firstly, the inner turntable remained locked for the greater part of the

investigation so that it moved automatically with the outer turntable in rotations about a vertical axis. Only the orientation of vertical axis A_3 need therefore be considered during any 360° rotation. Secondly, the horizontal axes remained fixed throughout the major part of the study. Horizontal axis A_2 was positioned parallel to the vertical crosswire—the North-South axis (EMMONS, 1943). The other horizontal axis A_4 remain parallel to the horizontal crosswire—the East-West axis (EMMONS, 1943).

Although the stage is capable of more complicated use, the two manipulations mainly employed were the following. One was the varying of the inclination of the plane of the section surface to the optic axis of the microscope. This is referred to as rotation about a horizontal axis, either A_2 or A_4 .

The other manipulation involved the rotation of the specimen through 360° about the optic axis of the microscope. The inclination of the plane of the section surface to the optic axis of the microscope remained constant during any one rotation. This is referred to as rotation about vertical axis A_3 . The rotation may take place either within a plane perpendicular to, or within a plane inclined to the optical axis of the microscope. In the latter situation, rotation of the outer turntable about horizontal axis A_4 effected the necessary inclination of vertical axis A_3 . The inclined vertical axis A_3 is then qualified by the appropriate A_4 index.

MATERIALS AND METHOD

Two thin bucco-lingual sections of canine premolar enamel were ground and polished largely after the method described by FREMLIN *et al.* (1961), to a thickness of approximately 12μ . The sections were mounted upon a Leitz four-axis universal rotating stage. The hemispheres and mountant used were both of refractive index 1.647. The universal rotating stage was then fixed to the stage of a polarizing microscope. The A_5 index was locked at 0° . Subsequent study was directed at an area in the middle third of the lateral plate of enamel of each specimen.

Incident illumination was obtained where required by means of a Leitz "Monla" lamp, the diaphragm of which was placed so as to produce as narrow a beam of light as was compatible with photographic requirements. The beam was angled at 45° to the horizontal and was directed in a plane perpendicular to the transverse axis of the microscope from the side opposite the observer. As each of the two specimens showed a different aspect of the study to best advantage, they will be treated separately.

Specimen A

An area was chosen for study. The area was positioned so that at A_3 index = 0° , the longitudinal axes of the rods in question were aligned parallel with the light path (Fig. 3). The following manipulations were carried out under incident light.

- (a) Rotation through 360° was affected about vertical axis A_3 with the A_4 index fixed at: (1) 0° ; (2) black 35° ; (3) red 20° .

During these rotations four positions were recorded. These were signified by the appropriate A_3 index— 0° , 90° , 180° and 270° .

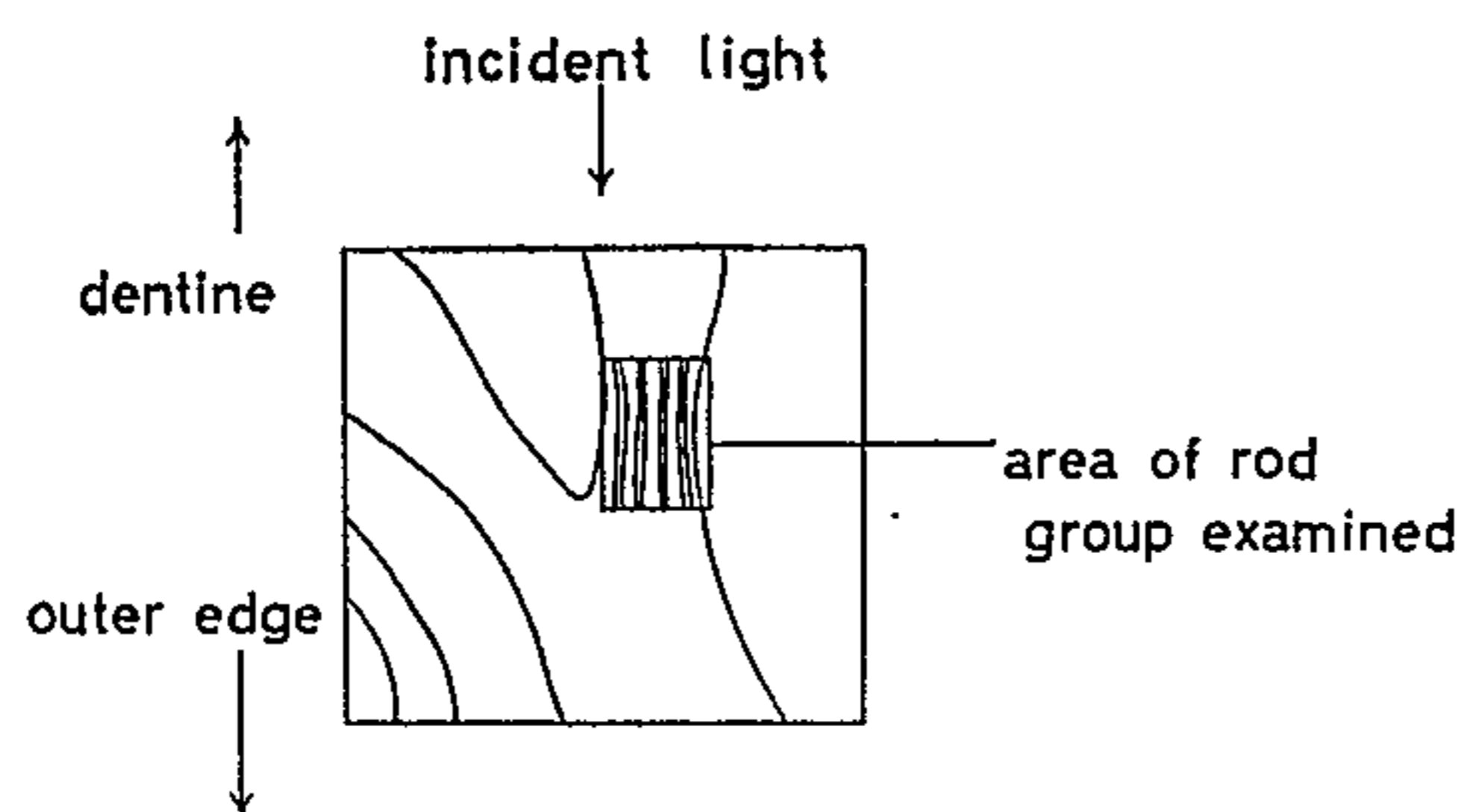

FIG. 3. Diagram of specimen A showing the portion of rod group examined and its relation to the incident light where A_3 index = 0° .

- (b) Rotation was effected about horizontal axis A_4 with the A_3 index fixed at: (1) 0° ; (2) 180° .

Throughout these manipulations the longitudinal axes of the rods were aligned parallel with the light path.

- (c) Lastly, rotation was effected about horizontal axis A_2 with the A_3 index fixed at: (1) 270° ; (2) 90° .

Throughout these manipulations the longitudinal axes of the rods were aligned perpendicular to the light path.

During rotation about horizontal axes A_2 or A_4 , usually of the order of 90° , any position where a marked change in appearance occurred was recorded and signified by the appropriate A_2 or A_4 index.

Specimen B

An area of a rod group was chosen for study. The particular region was then orientated to appear at the junction of the crosswires with the longitudinal axes of the rods roughly parallel to the vertical crosswire (Fig. 4).

1. *Examination by transmitted polarized light*

A position within the horizontal plane was sought at which the area concerned exhibited birefringence. This position was found by rotating the specimen about vertical axis A_1 with the A_2 , A_3 and A_4 indices fixed at 0° . Polars were crossed with axes at 45° to the crosswires. The position of birefringence was taken as that midway

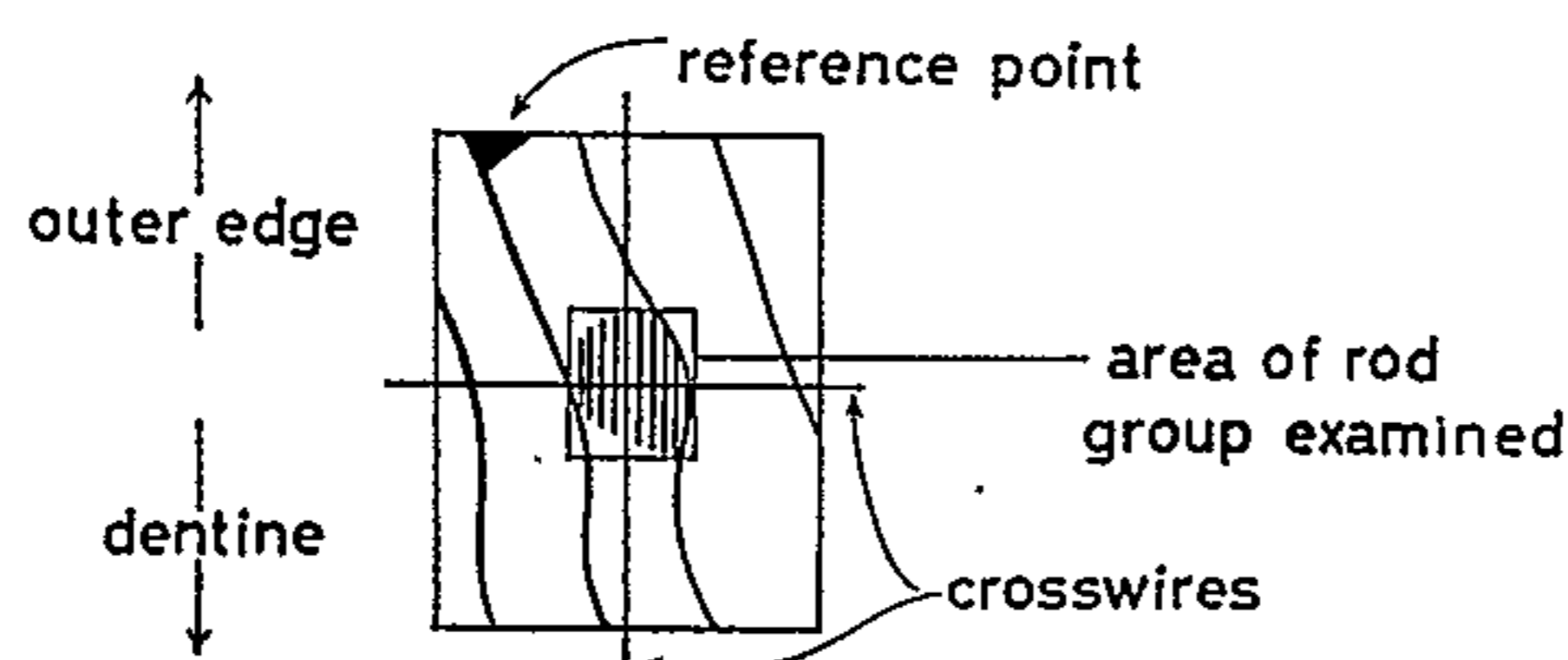

FIG. 4. Diagram of specimen B showing the portion of rod group examined and its relation to the crosswires.

between two extinction positions occurring on either side. The specimen was locked in the position of birefringence with respect to axis A_1 .

Rotation was then effected about horizontal axis A_4 . That is to say, alteration was made to the inclination of the longitudinal axes of the rods to the horizontal. The behaviour of the rod group and particularly the position of maximal birefringence within this rotation was noted. Two methods aided the assessment of the position of maximal birefringence. One was to reduce the compensator reading, the compensator being normally set for background extinction. The reduction opposed the specimen birefringence making its appearance within the rotation more critical. The other indication was the number of periodicities that could be brought into focus within the rods in the area concerned. The number should be maximal when the rods are horizontal.

2. Examination by incident light

- (a) The positions at which the particular region of the rod group examined appeared maximally bright were determined in the following planes.

With the A_3 index fixed at (1) 0° ; (2) 180° ; rotation was effected about horizontal axis A_4 . Throughout both these rotations the longitudinal axes of the rods were aligned parallel with the light path.

With the A_3 index fixed at (3) 90° ; (4) 270° ; rotation was effected about horizontal axis A_2 . Throughout both these rotations the longitudinal axes of the rods were aligned perpendicular to the light path.

- (b) With the rod group in the maximally bright position found previously where (1) the A_3 index was fixed at 0° , rotation was then effected about horizontal axis A_2 ; (2) the A_3 index was fixed at 90° , rotation was then effected about horizontal axis A_4 .

In both these manipulations there resulted a rotation of the rod group about its approximate longitudinal axis. In the first rotation the rods were aligned parallel with the light path and in the second, perpendicular to it.

RESULTS

Specimen A

The following were the changes in appearance of the area concerned (Fig. 3) during the manipulations listed previously in similar order.

- (a) (1) at A_3 index = 0° , the area under examination appeared with a dark central region which was bordered on each side by two lighter segments. With rotation the lighter segments appeared to migrate towards each other until at A_3 index = 90° they had fused to form a light band. With further rotation of the specimen, the light band began to fade and at A_3 index = 180° the area was dark. The area became light again by the time A_3 index = 270° , but on continued rotation back to A_3 index = 0° , there was an apparent gradual splitting of the light band to result in the appearance initially described (Fig. 5).

- (2) The area remained light, least defined at A_3 index = 0° throughout the entire 360° rotation (Fig. 6).
- (3) Here the area appeared dark at A_3 index = 0° and 180° , and light where A_3 index = 90° and 270° . Transition was gradual with no appearance of splitting at any stage (Fig. 7).
- (b) (1) The area was initially dark (Fig. 8a) at A_4 index = 30° . With rotation it assumed a "split" appearance (Fig. 8b, c) and, with further apparent migration of segments from the previously adjacent light bands, became light at A_4 index = black 10° (Fig. 8d). With further rotation there was a gradual fading and a return to darkness at A_4 index = black 45° (Fig. 8f).
- (2) The sequence was similar to that of (1) when the direction of rotation was the same.
- (c) (1) The area exhibited firstly a "split" appearance at A_2 index = L.H.S. 35° (Fig. 9a). With further rotation, this gave way to a light band at A_2 index = 0° (Fig. 9b, c) and finally to a dark band at A_2 index = R.H.S. 35° (Fig. 9d, e).
- (2) The sequence was the reverse of (1) when the direction of rotation was the same.

Specimen B

1. *Examination by transmitted polarized light.* The position at which the area concerned (Fig. 4) exhibited birefringence within the horizontal plane was found to be where the rods were seen to be aligned parallel to the vertical crosswire (Fig. 10b).

With rotation about horizontal axis A_4 , the rod group appeared relatively isotropic in the black quadrant (Fig. 10d) and birefringent in the red quadrant. The position of maximal birefringence within this rotation was close to the point where A_4 index = red 16° (Fig. 10c).

2. *Examination by incident light*

- (a) The positions where the area appeared maximally bright (Fig. 11) were found to be in their respective planes where:
- (1) A_4 index = black 7° ;
 - (2) A_4 index = black 41° ;
 - (3) A_2 index = L.H.S. 15° ;
 - (4) A_2 index = R.H.S. 15° .
- (b) When rotated in this manner at both settings, to the degree permitted by the apparatus (approximately 45° in either direction), the total area photographed was not without some change in appearance (Figs. 12 and 13). However, the area in question largely retained its bright appearance.

DISCUSSION

Specimen A

Rotation about vertical axis A_3 involves rotation of the specimen through 360° relative to the light path. The classically described sequence for such rotation is one of band reversal from light to dark and vice versa on rotation through 180° (CZERMAK, 1850; VON EBNER, 1902). It may be seen that the behaviour of the area examined does not wholly comply with this (Fig. 5). Indeed with rotation about an inclined

vertical axis there may be no reversal at all (Fig. 6). When reversal does occur it may do so with rotation through only 90° (Fig. 7). Again, the sequence of changes occurring in a particular area may be altered by varying the inclination of the vertical axis about which the rotation occurs (see Figs. 5, 6 and 7).

It is apparent that band reversal can also be achieved by rotation of the specimen about a horizontal axis (Figs. 8 and 9). This rotation effects an alteration of the inclination of the plane of the section surface to the incident light. Reversal occurs for both a parallel and a perpendicular alignment of rods with the light path. The reversal may be realized through only 40° of rotation. A specific area may return to a dark appearance with rotation through the full 90° permitted by the apparatus (Fig. 8). No area in any specimen yet examined has failed to show an alteration in appearance with rotation of the specimen in this manner.

For a series of dark and light bands presented by a specimen at a particular orientation, the "split" light band appearance will only occur if, with rotation, there is to be some change also in the adjacent dark bands. If the overall change is to be one of mutual reversal then the segments of the "split" light bands will appear to migrate away from each other completely (LESTER, 1965). On the other hand, if mutual reversal is not fully realized, the segments appear to migrate only a little way.

It must be emphasized that the appearances described depend largely upon the thickness of the section. With thicker sections (as used by the early investigators) underlying rods groups appear to affect the nature and clarity of band appearance. An understanding of the behaviour of specimen *A* is facilitated by consideration of specimen *B*.

Specimen B

1. *Examination by transmitted polarized light.* The first position of birefringence occurred with the rods at an angle of 45° to the polars. Because the crystallites are negatively birefringent, this confirms a parallelism of the mean longitudinal axis of the enamel crystallites and the rod longitudinal axis. This was noted previously by CAPE and KITCHEN (1930).

The second position of birefringence described at A_4 index = red 16° , is that where the mean longitudinal axis of the crystallites in the area examined is horizontally aligned. Because there is known to be little deviation of mean crystallite axis and rod longitudinal axis in a transverse mesio-distal plane (CAPE and KITCHIN, 1930; POOLE and BROOKS, 1961; GLAS, 1962) the rods in the area may also be assumed to lie horizontally when the specimen is in this position. Taking into account the topography of the specimen, it is possible to conclude the following. The rods in the area examined pass away from the upper surface of the section in the direction of the outer enamel edge at an angle of approximately 16° . The rods may now be represented diagrammatically at any given setting of the universal rotating stage (Fig. 14).

2. *Examination by incident light.* The purpose here is not to argue the presence of reflexion. It is apparent that reflexion must occur if the appearance of brightness is to be exhibited with incident light the sole means of illumination. The purpose is rather to enquire into the source of the reflexion. More specifically, to show that a

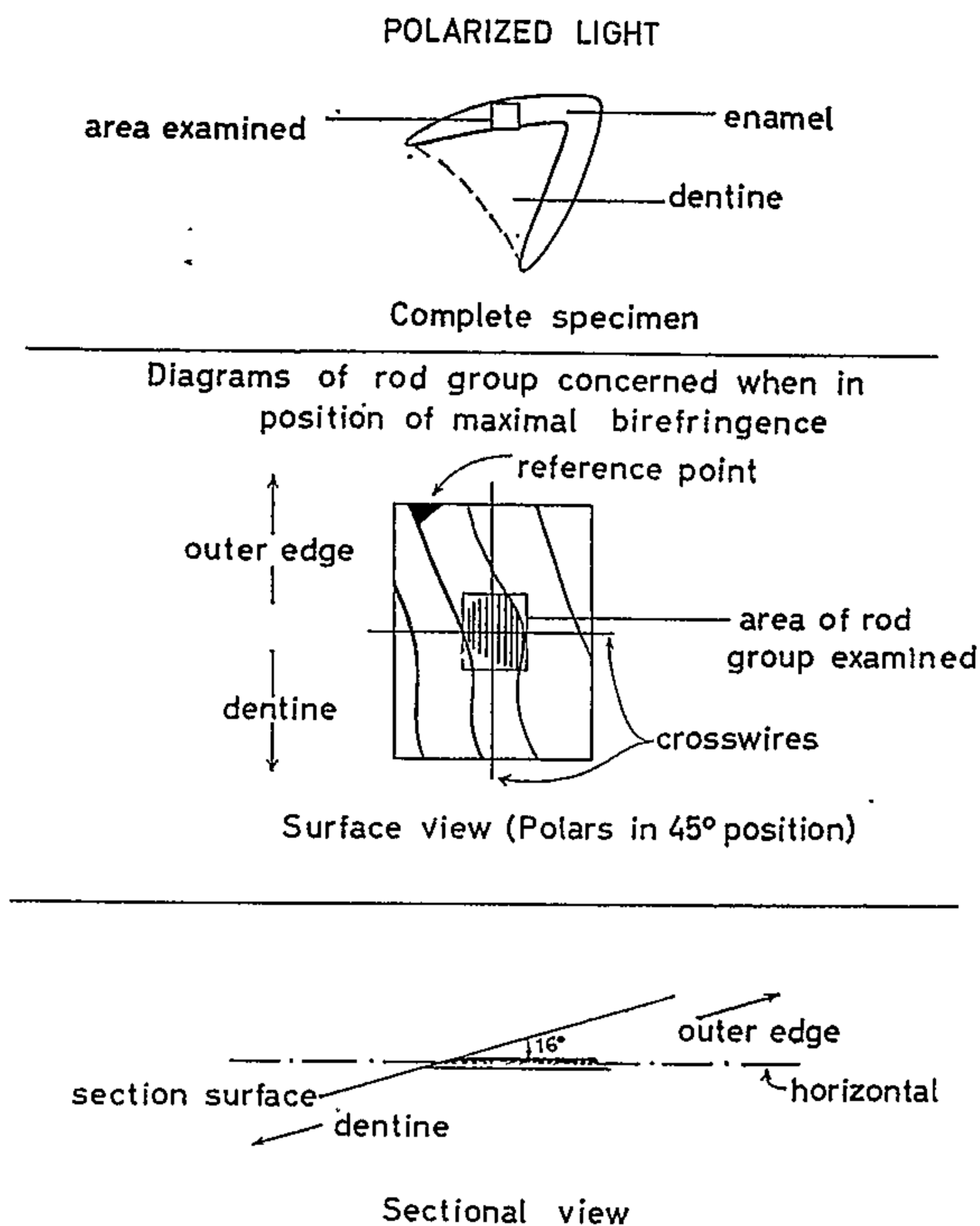

FIG. 14. Diagrams of specimen B.

- (a) Relation of area examined to whole specimen.
 (b) Portion of rod group examined shown at the junction of the crosswires.
 (c) Representative rod of group when the specimen is in the position of maximal birefringence about horizontal axis A_4 .

rod group, when orientated to satisfy the laws of reflexion, presents the appearance of a maximally bright band of Schreger.

Firstly, the two rotations of the area about horizontal axis A_4 will be considered theoretically. Throughout these rotations the rods are aligned parallel to the light path. Within each of the rotations there is one orientation of the rods which can satisfy the laws of reflexion as applied to the particular experimental system. Each orientation may be represented diagrammatically (Figs 15 and 16). The hypothetical stage readings would be:

- (i) with the A_3 index fixed at 0° , A_4 index = black 6.5° ;
 (ii) with the A_3 index fixed at 180° , A_4 index = black 38.5° .

These compare favourably with the stage readings for the positions of maximal brightness found experimentally—black 7° and black 41° respectively.

Secondly, the two rotations of the area about horizontal axis A_2 will be considered. Throughout these rotations the rods are aligned perpendicular to the light path. Theoretically, for reflexion to occur there is but one possible orientation of the rod group. This applies to both settings of the A_3 index, in this case 90° and 270° .

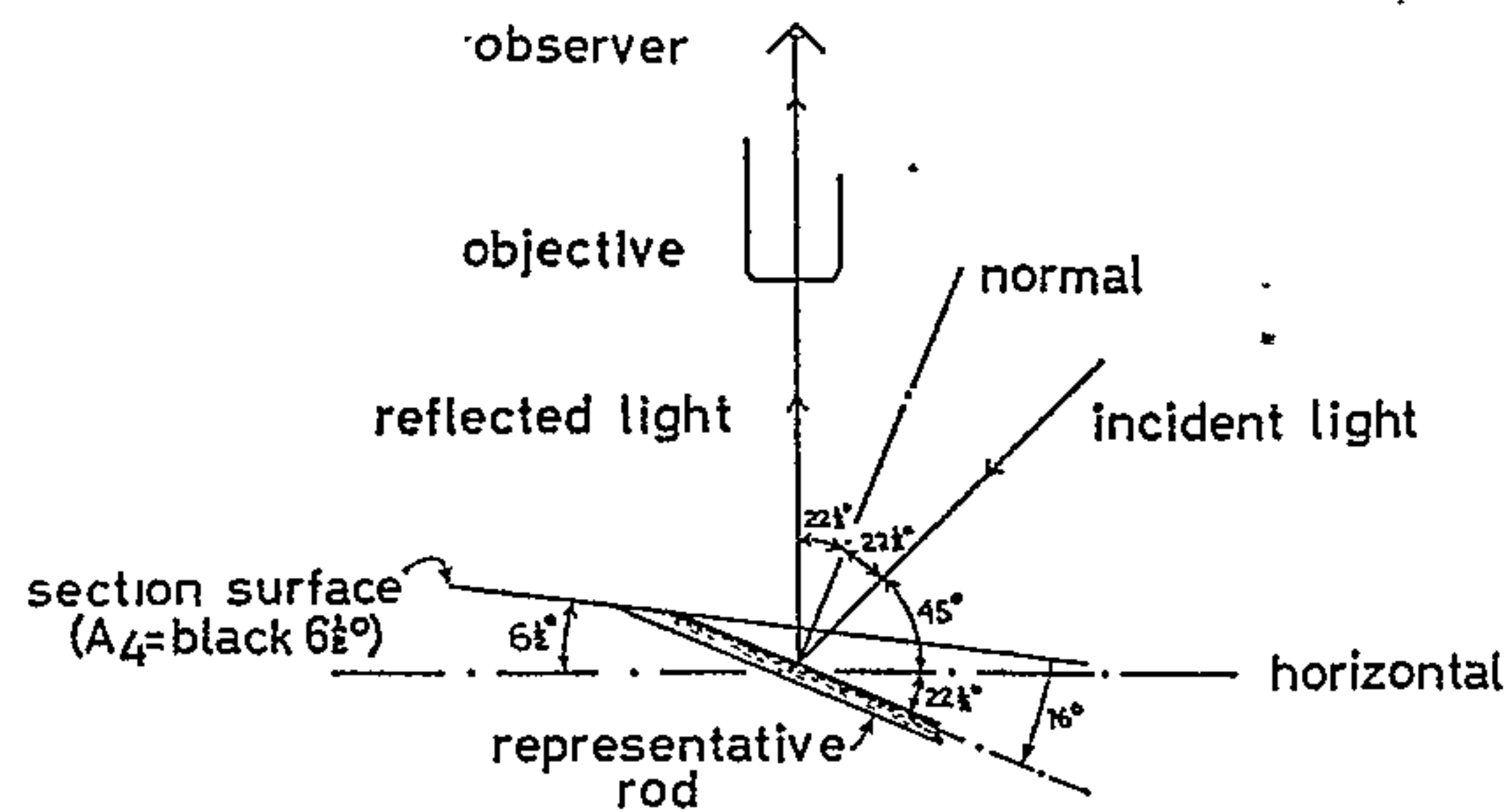

FIG. 15. Diagram showing theoretical treatment of maximal reflexion where the A_3 index is fixed at 0° .

Only when the longitudinal axis of the rod group is horizontally aligned could the incident ray, the normal, the reflected ray and the objective lie in the one plane. Such an alignment is essential to reflexion and may be represented diagrammatically (Fig. 17). The hypothetical stage readings would be

- (i) with the A_3 index fixed at 90° , A_2 index = L.H.S. 16° ;
- (ii) with the A_3 index fixed at 270° , A_2 index = R.H.S. 16° .

Again there is a favourable comparison with the stage readings for the positions of maximal brightness found experimentally—L.H.S. 15° and R.H.S. 15° .

It is doubly apparent, however, that the rod group cannot be regarded as presenting a simple plane mirror surface along its length. Firstly, during rotation of the area about horizontal axis A_2 as stated, the rods are aligned perpendicular to the light path. Incident light angled at 45° to the horizontal could not be reflected from a point on a horizontal plane mirror to enter an objective perpendicularly above that point. Secondly, when the rod group is rotated about its approximate longitudinal axis there is little change in reflective behaviour. This would not be so if the rod group acted as a plane mirror.

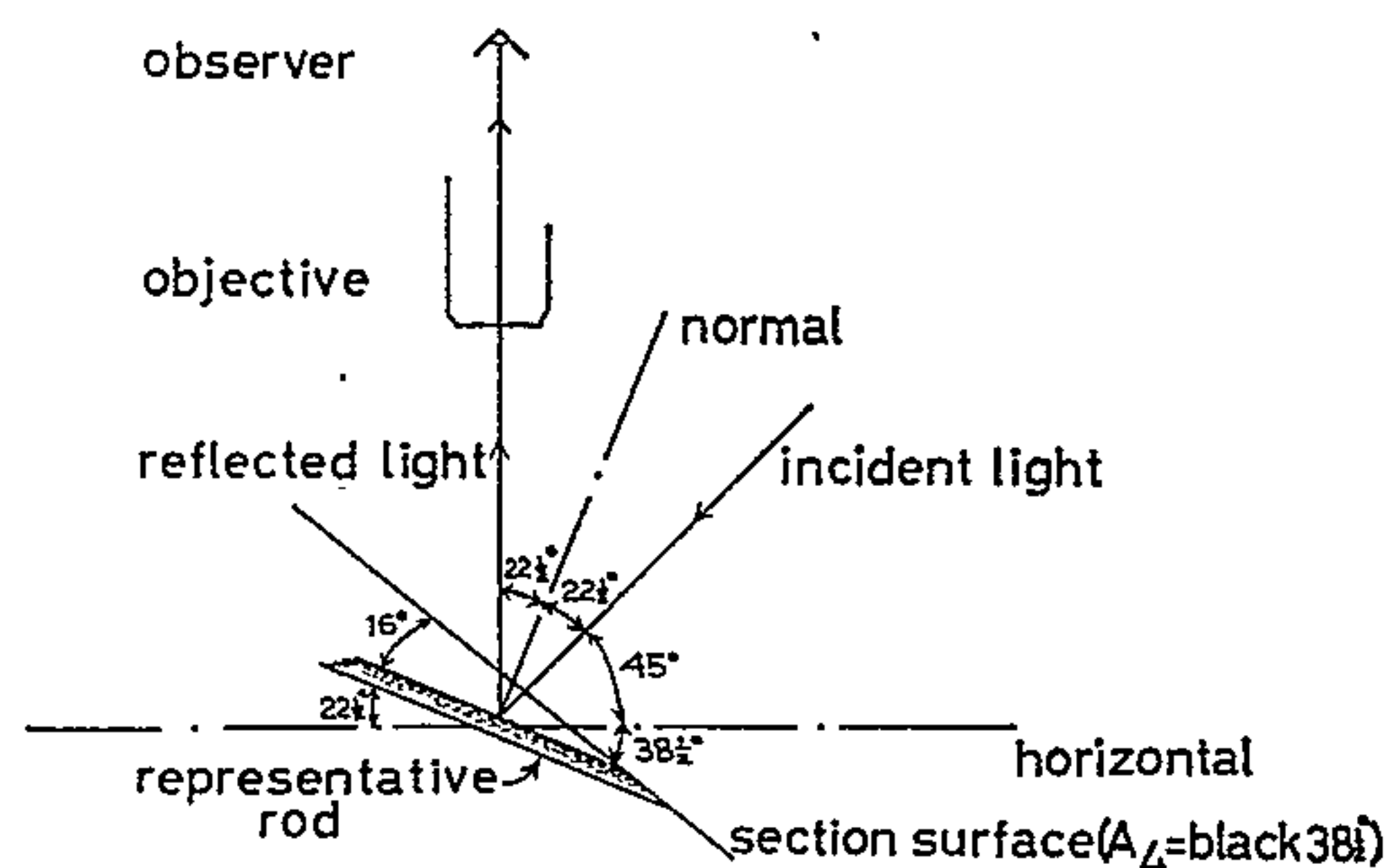

FIG. 16. Diagram showing theoretical treatment of maximal reflexion where the A_3 index is fixed at 180° .

Both considerations indicate that the rods act as cylindrical mirrors with the longitudinal axis of the cylinder coincident with that of the rod. This configuration would allow of the major reflective change found with rotation about the rod transverse axis and the lack of significant change found with rotation about the rod longitudinal axis.

It would seem therefore, that in a thin ground bucco-lingual section of canine dental enamel, a maximally bright band of Schreger may be explained by the reflexion of incident light to the observer by a portion of a rod group of suitable orientation.

The rods for this particular purpose are best regarded as elongated cylindrical mirrors. Any rotational sequence of band appearance may be accounted for by the rods remaining in, or moving away from a position of maximal reflexion. The apparent

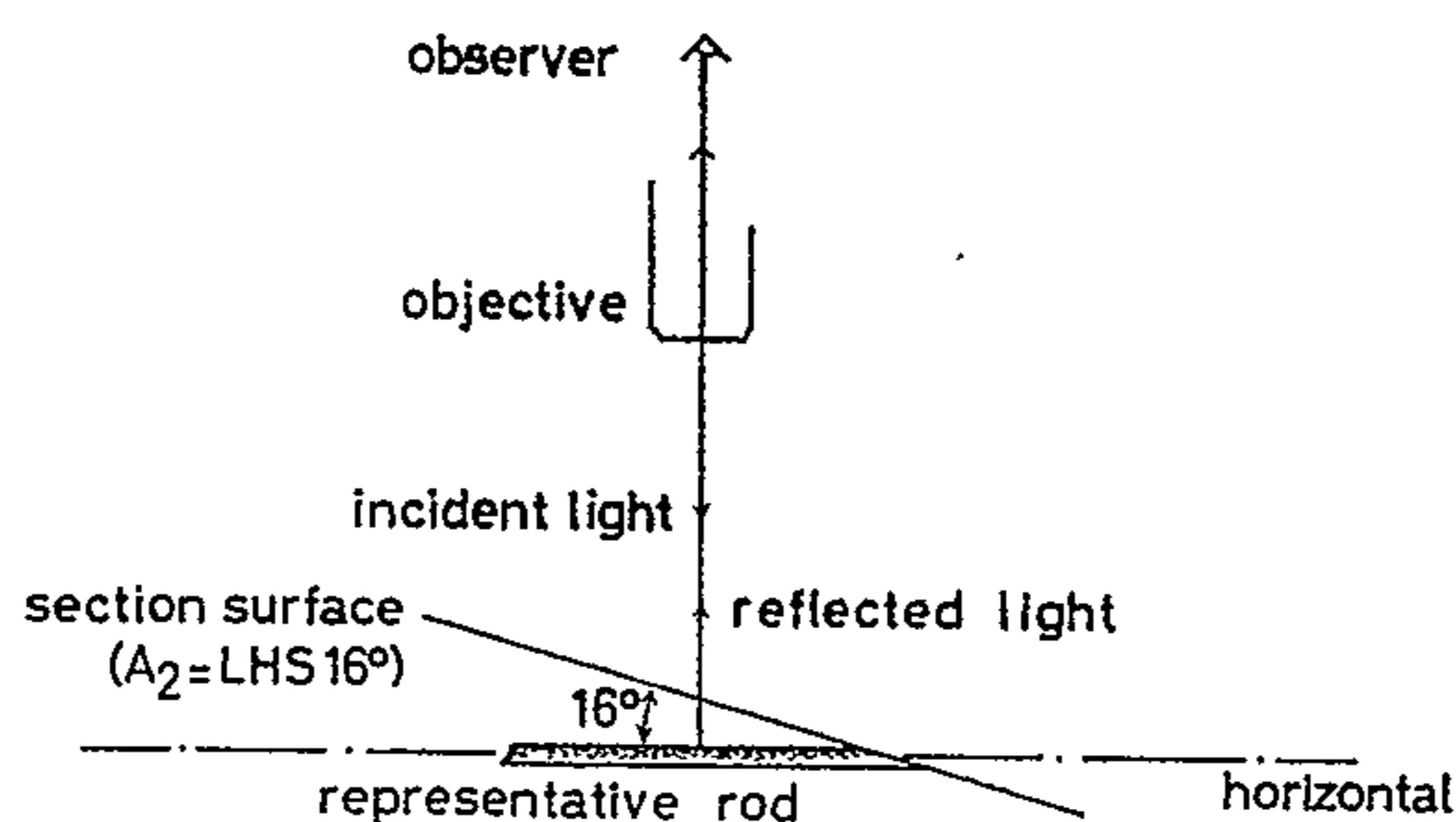

FIG. 17. Diagram showing theoretical treatment of maximal reflexion where the A_2 index is fixed at 90° .

migration of the segments of a "split" light band within some sequences finds explanation in the gradual change in rod direction known to occur at rod group boundaries (VON EBNER, 1902; LEHNER and PLENK, 1936; HEUSER, 1961).

The conditions to be met for rods to exhibit significantly different reflective appearances may be specified in two situations. The first situation is where the longitudinal axes of the rods appear parallel to the observer but in fact do not lie in the same plane. Their longitudinal axes must then differ in vertical inclination to the incident light by at least 20° . The second situation is where the longitudinal axes of the rods lie in the same plane and have an identical vertical inclination to the incident light. In this case their longitudinal axes must be inclined to each other within the plane in which they lie, at an angle of at least 45° . For well defined bands of Schreger to appear, the longitudinal axes considered in these two situations would apply to the mean longitudinal axes of adjacent portions of rod groups.

Throughout this discussion, reflexion has been related to the longitudinal axis of the enamel rod. However, it is apparent that emphasis could better be shifted to the mean longitudinal axis of the crystallites. Although coincident to the rod longitudinal axis in canine enamel and closely related in human enamel, this crystallite axis is, theoretically at least, the more basic consideration.

Résumé—Deux coupes, par usure, minces bucco-linguales d'émail dentaire de canine sont étudiées à l'aide d'un microscope polarisant présentant un dispositif de rotation universel à quatre axes. L'un des spécimens subit une rotation à la fois autour des axes verticaux et inclinés verticalement et autour des axes horizontaux sous une source fixe de lumière incidente. Chaque rotation donne un aspect spécifique différent aux bandes de Schreger.

Le second spécimen est étudié par 2 méthodes. Tout d'abord, en lumière polarisée transmise, l'inclinaison des prismes par rapport à la surface de coupe est déterminée dans une zone particulière d'un groupe de prismes. Deuxièmement, sous lumière incidente, un certain nombre de positions, dans lesquelles cette région particulière du groupe prismatique donne une réflexion maximale, sont notées. Il fut démontré que les prismes apparaissent comme une bande de Schreger d'intensité maximum lorsqu'ils sont orientés par rapport à la lumière incidente, de telle sorte qu'ils obéissent aux lois de la réflexion. La réflectivité des prismes s'explique le mieux les considérant comme des miroirs cylindriques allongés.

Zusammenfassung—Zwei dünne, bucco-lingual geschliffene Schnitte durch den Eckzahn-schmelz wurden mit Hilfe eines um vier Achsen schwenkbaren Objektives untersucht. Ein Prüfkörper wurde sowohl über die vertikalen und über die geneigt-vertikalen Achsen als auch über horizontale Achsen bei fixierter Quelle einfallenden Lichtes untersucht. Jede Rotation ergab eine unterschiedliche, spezifische Folge von Erscheinungen der Schreger'schen Streifen.

Das zweite Prüfobjekt wurde auf zweierlei Weise untersucht. Einerseits wurde in einem bestimmten Teil einer Prismengruppe mit durchfallendem, polarisiertem Licht der Winkel der Schmelzprismen zur Schliffoberfläche abgeschätzt. Andererseits wurden bei auffallendem Licht eine Anzahl Positionen gefunden, bei denen dieser bestimmte Teil der Prismengruppe maximal reflektierte. Es war möglich zu zeigen, dass die Prismen dann als maximal breiter Schreger-Streifen erschienen, wenn sie in Beziehung zum einfallenden Licht so orientiert waren, dass sie den Reflektionsgesetzen genügten. Die Reflektion der Prismen liess sich am besten erklären, wenn man sie wie verlängerte, zylindrisch wirkende Spiegel betrachtete.

REFERENCES

- AWAZAWA, Y. and ONO, A. 1961. Electron microscopy of Hunter-Schreger bands in bovine enamel. *J. Nihon Univ. Sch. Dentistry* 3, 163-168.
- BERKE, J. D. 1936. Studies in the histology and pathology of human enamel. *Dent. Cosmos* 78, 700-710.
- CAPE, A. T. and KITCHIN, P. C. 1930. Histologic phenomena of tooth tissues as observed under polarized light; with a note on the roentgen ray spectra of enamel and dentine. *J. Amer. dent. Ass.* 17, 193-227.
- CARLSTRÖM, D. and GLAS, J. E. 1963. Studies on the ultrastructure of dental enamel. III. The bi-refringence of human enamel. *J. Ultrastruct. Res.* 8, 1-11.
- CHURCHILL, H. R. 1936. *Meyer's Histology and Histogenesis of the Human Teeth*. Chapt. I, p. 27. Lippincott, Philadelphia.
- CZERMAK, J. N. 1850. Beiträge zur mikroskopischen Anatomie der menschlichen Zähne. *Zeitschrift für wissenschaftliche Zoologie* (Edited by SIEBOLD, C. Th. v. and KÖLLIKER, A.) p. 295. Engelmann, Leipzig.
- DE BOER, J. G. and STIEBELING, G. 1958. Ein Beitrag zur Erklärung der Schreger'schen Streifen. *Stoma* 4, 157-164.
- EBNER, V. v. 1902. Von den Zähnen: *Kölliker's Handbuch der Gewebelehre des Menschen*. Vol. 3, p. 87. Engelmann, Leipzig.
- EMMONS, R. C. 1943. The Universal Stage. Memoir 8, p. 13. The Geological Society of America, Washington.

- ERAUSQUIN, J. 1949. The aspect of the bands of Schreger in the horizontal section of the enamel. *J. dent. Res.* **28**, 195-200.
- FREMLIN, J. H., MATHIESON, J. and HARDWICK, J. L. 1961. The preparation of thin sections of dental enamel. *Arch. oral Biol.* **5**, 55-60.
- GLAS, J. E. 1962. Studies on the ultrastructure of dental enamel—III. The orientation of the apatite crystallites as deduced from X-ray diffraction. *Arch. oral Biol.* **7**, 91-104.
- HEUSER, H. 1961. Die Struktur des menschlichen Zähnschmelzes im oberflächen histologischen Bild (Replica-Technik). *Arch. oral Biol. Special Supplement*, **4**, 50-58.
- HOLLANDER, F., BODECKER, C. F., APPLEBAUM, E. and SAPER, E. 1935. A study of the bands of Schreger by histological and Grenz-ray methods. *Dent. Cosmos.* **77**, 12-20.
- LEHNER, J. and PLENK, H. 1936. *Die Zähne: von Möllendorff's Handbuch der mikroskopischen Anatomie des Menschen*. Vol. 5: 3, p. 541. Springer, Berlin.
- LESTER, K. S. 1965. The variability of the bands of Schreger. *Austral. dent. J.* In press.
- LYON, D. G. and DARLING, A. I. 1957. Orientation of the crystallites in human dental enamel—I. *Brit. dent. J.* **102**, 483-488.
- MANLEY, E. B., BRAIN, E. B. and MARSLAND, E. A. 1955. *An Atlas of Dental Histology*. (2nd. ed.) p. I. Blackwells, Oxford.
- MORTELL, J. F. and PEYTON, F. A. 1956. Observations of Hunter-Schreger bands. *J. dent. Res.* **35**, 804-813.
- PICKERILL, H. P. 1913. The structure of enamel. *Dent. Cosmos.* **55**, 969-988.
- POOLE, D. F. G. and BROOKS, A. W. 1961. The arrangement of crystallites in enamel prisms. *Arch. oral Biol.* **5**, 14-26.
- SAUNDERS, J., NUCKOLLS, J. and FRISBIE, H. E. 1944. Amelogenesis. A histological study of the development, formation and calcification of the enamel in the molar tooth of the rat. *J. Amer. Coll. Dent.* **9**, 107-136.
- SCHOUR, I. 1960. *Noye's Oral Histology and Embryology*. Chapt. 6, p. 106. Kimpton, London.
- SCOTT, J. H. and SYMONS, N. B. B. 1952. *Introduction to Dental Anatomy*, p. 55. Livingstone, Edinburgh.
- SCOTT, D. B. and WYCKOFF, R. W. G. 1947. Shadowed replicas of ground sections through teeth. *Publ. Hlth Rep. (Wash.)* **62**, 422-425.
- STAZ, J. 1946. Bands of Schreger. *J. dent. Res.* **25**, 373-380.
- THEWLIS, J. 1940. The structure of teeth as shown by X-ray examination. Medical Research Council. Spec. Rep. Ser. No. 238.
- WIDDOWSON, T. W. 1952. *Special or Dental Anatomy and Physiology and Dental Histology*. Chapt. 8, p. 151. Staples, London.
- YAMAKAWA, K. 1959. Comparative anatomical studies on the enamel structure of the rodents. *Acta anat. Nippon.* **34**, 852-866.

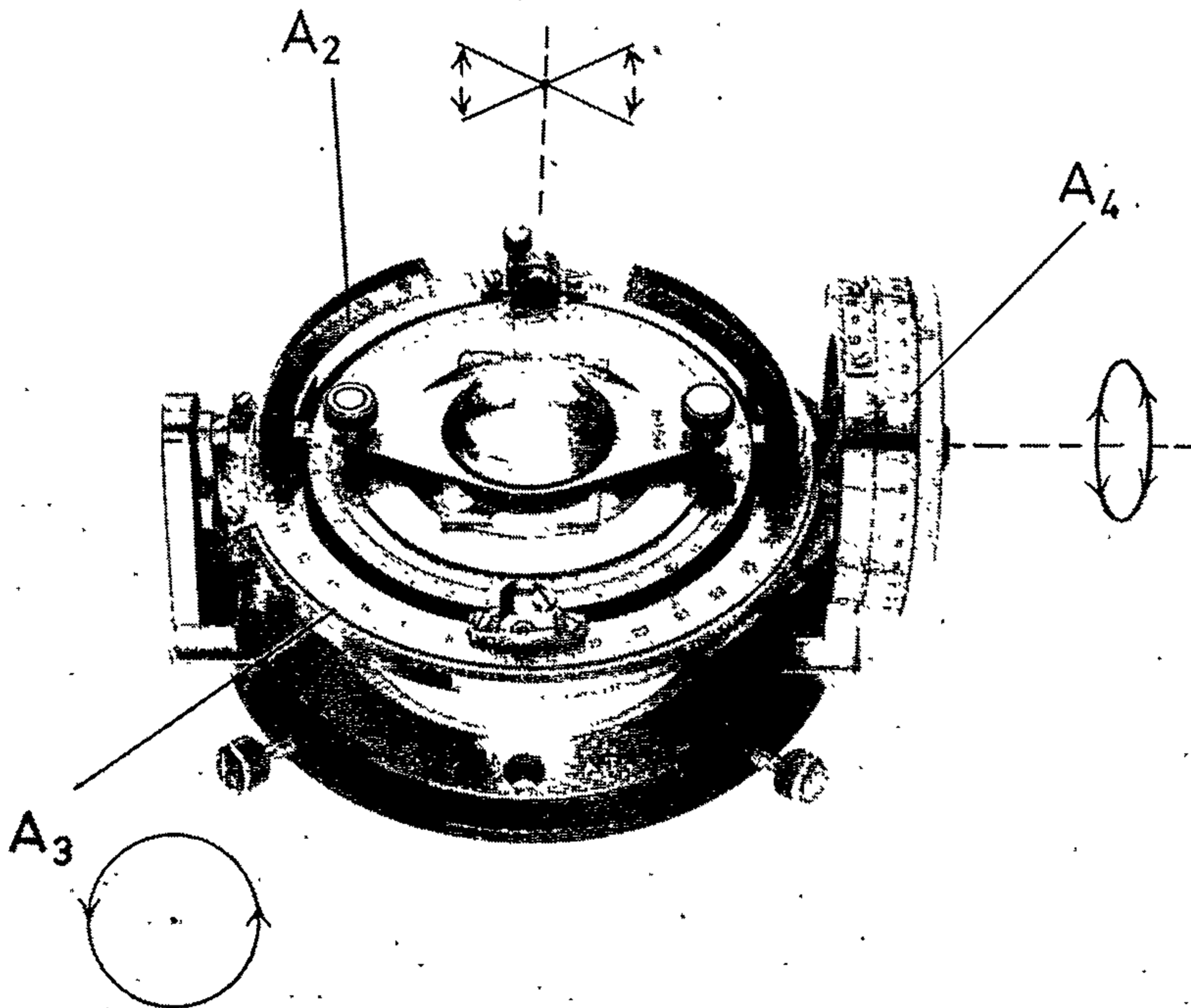

FIG. 1. The Leitz four-axis universal rotating stage (UT4). The means of calibration for each of the three axes employed is indicated. The corresponding direction of rotation is represented diagrammatically.

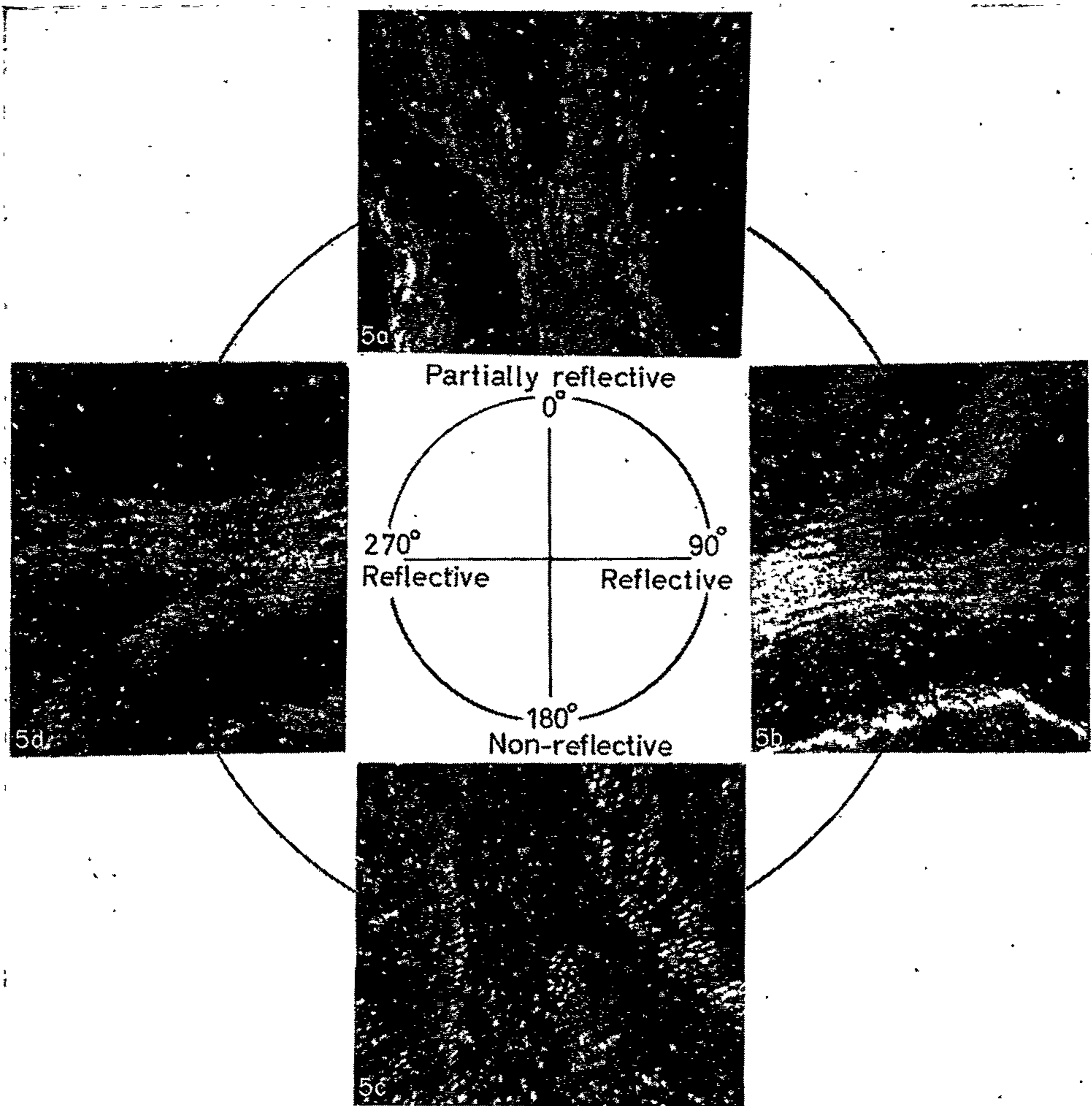

FIG. 5. Rotation of specimen A under incident light, about vertical axis A_3 with the A_4 index fixed at 0° .

- (a) A_3 index = 0°
 - (b) A_3 index = 90°
 - (c) A_3 index = 180°
 - (d) A_3 index = 270°
- × 450

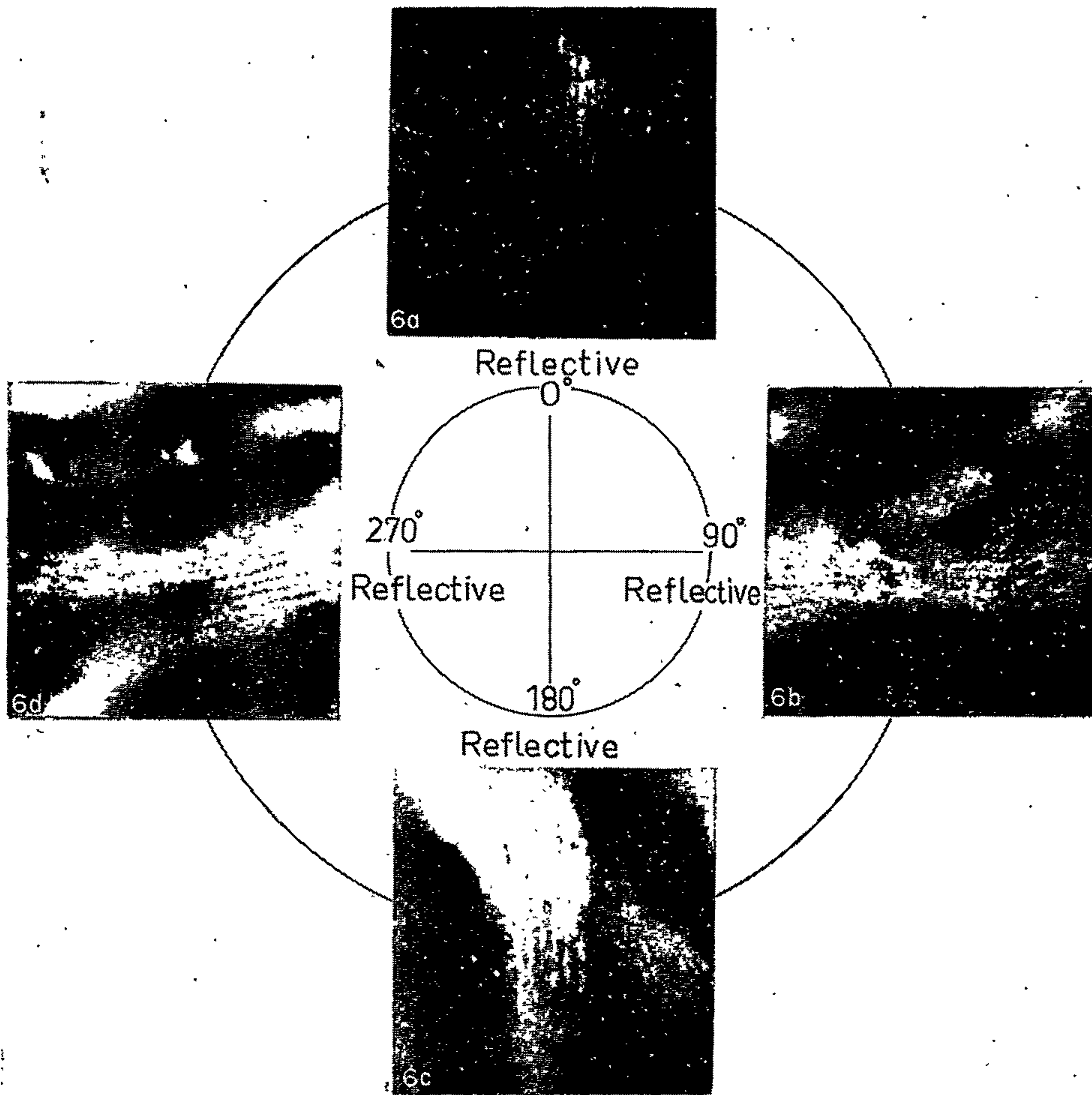

FIG. 6. Rotation of specimen A under incident light, about inclined vertical axis A_3 with the A_4 index fixed at black 35° .

- (a) A_3 index = 0°
 - (b) A_3 index = 90°
 - (c) A_3 index = 180°
 - (d) A_3 index = 270°
- × 450

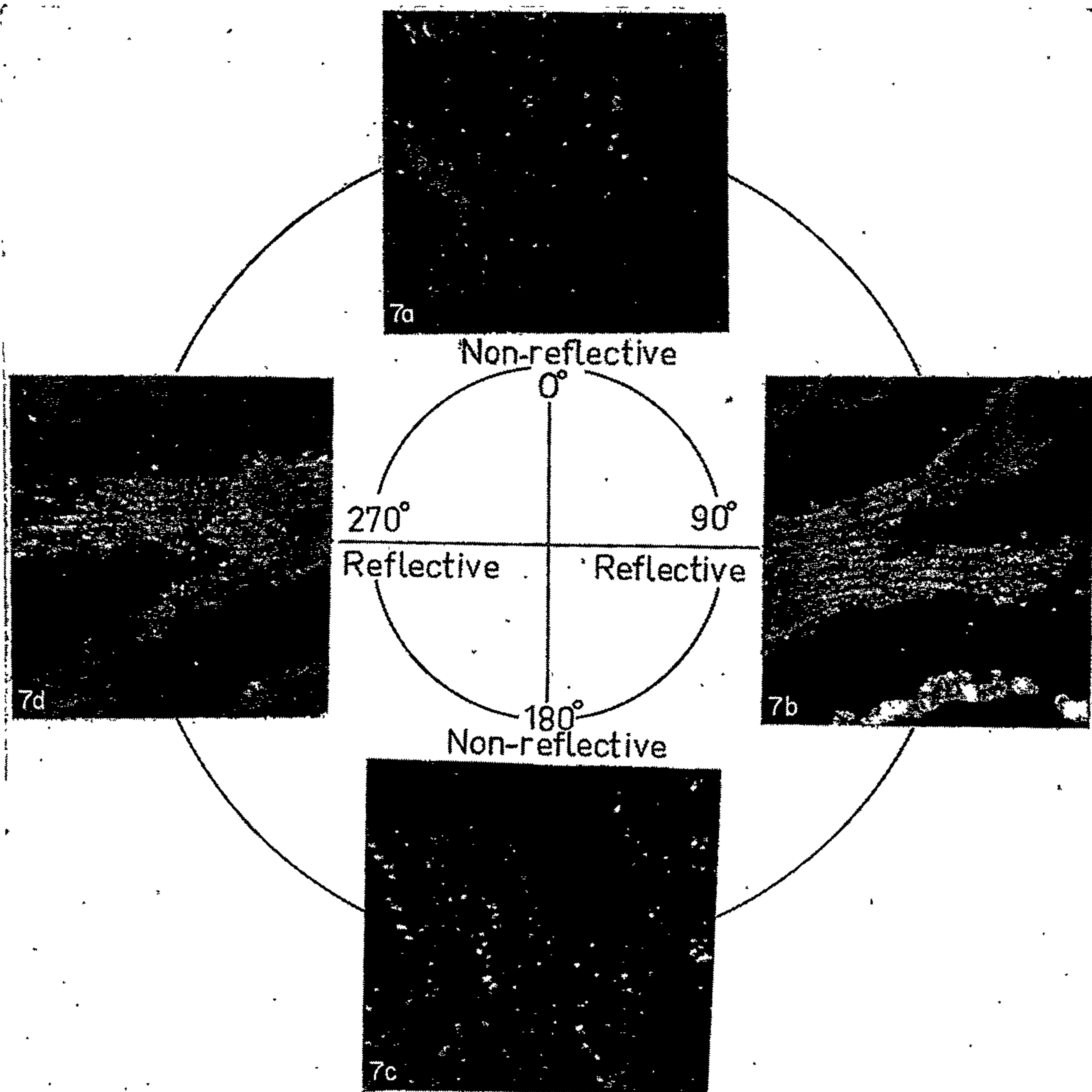

FIG. 7. Rotation of specimen A under incident light, about inclined vertical axis A_3 with the A_4 index fixed at red 20° .

- (a) A_3 index = 0°
 - (b) A_3 index = 90°
 - (c) A_3 index = 180°
 - (d) A_3 index = 270°
- × 450

THE BANDS OF SCHREGER: THE ROLE OF REFLEXION

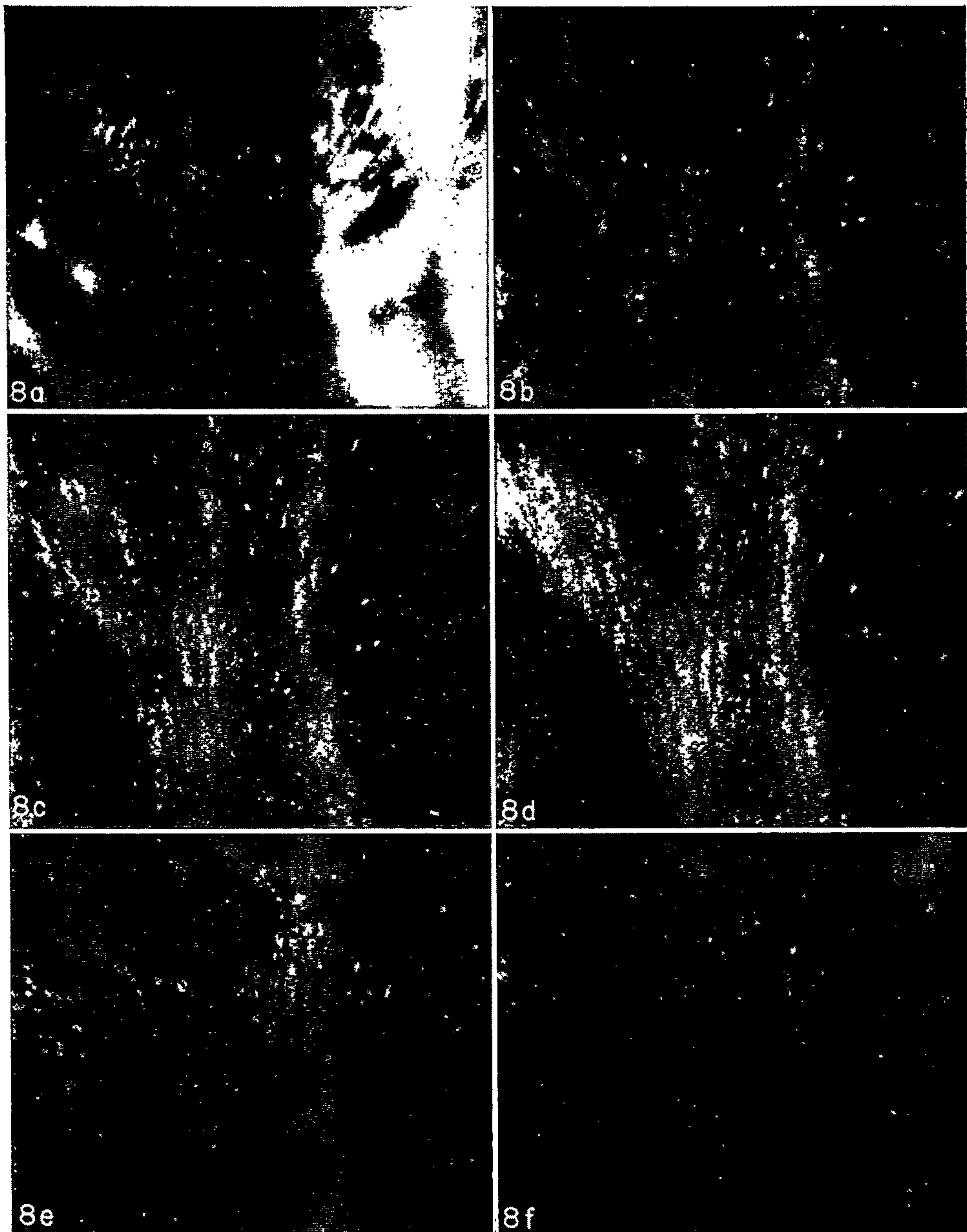

FIG. 8. Rotation of specimen A under incident light about horizontal axis A_4 with the A_3 index fixed at 0° .

- (a) A_4 index = red 30°
- (b) A_4 index = red 10°
- (c) A_4 index = 0°
- (d) A_4 index = black 10°
- (e) A_4 index = black 35°
- (f) A_4 index = black 45°

f. plate 4

$\times 450$

PLATE 5

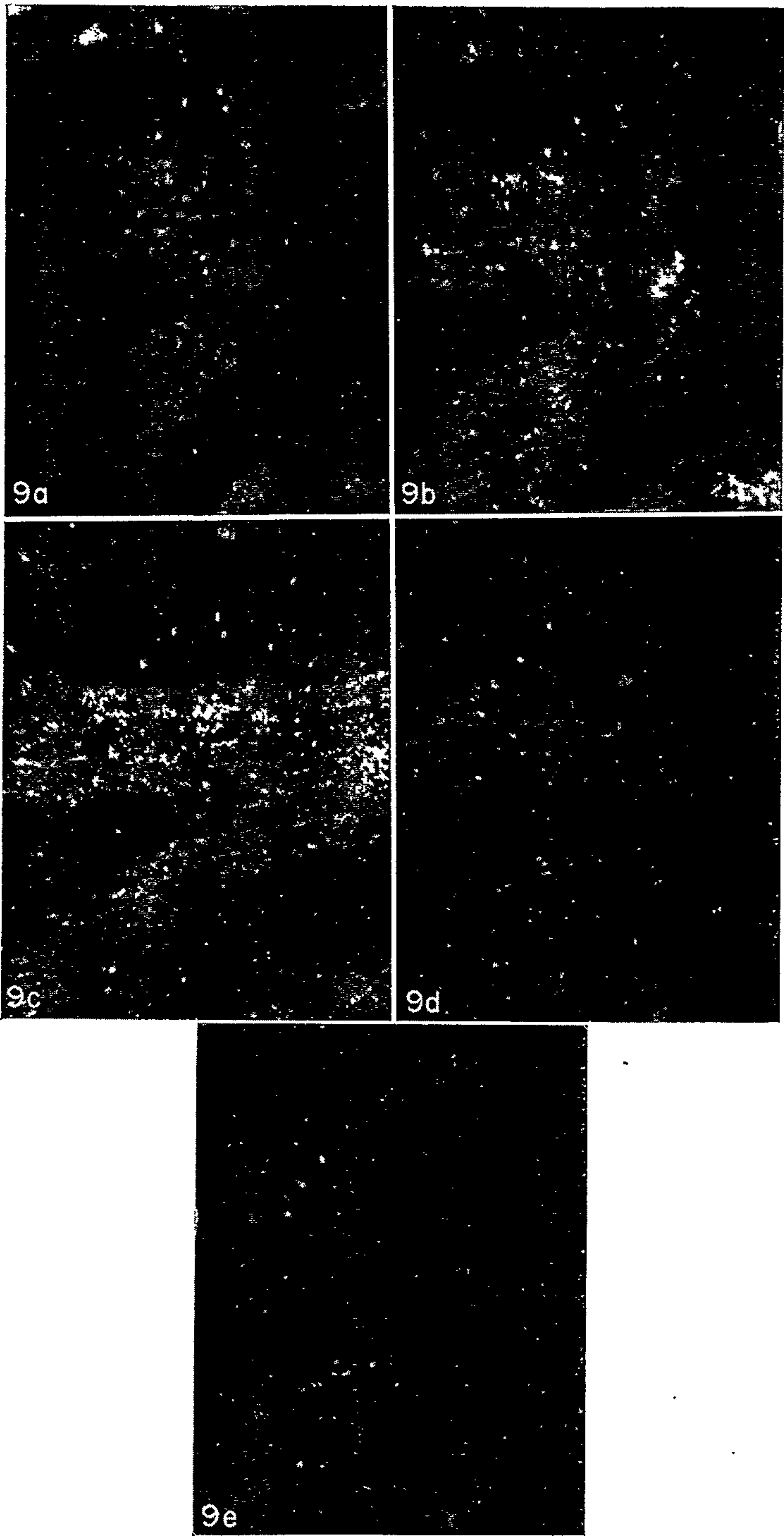

PLATE 6

FIG. 9. Rotation of specimen A under incident light about horizontal axis A_2 with the A_3 index fixed at 270°

- (a) A_2 index = L.H.S. 35°
 - (b) A_2 index = L.H.S. 20°
 - (c) A_2 index = 0°
 - (d) A_2 index = R.H.S. 20°
 - (e) A_2 index = R.H.S. 35°
- × 450

PLATE 7

FIG. 10. Specimen B by polarized light showing the portion of rod group examined in the following positions:

- (a) position of extinction about vertical axis A_1
- (b) position of birefringence about vertical axis A_1
- (c) position of maximal birefringence about horizontal axis A_4 , where A_4 index = red 16°
- (d) position of relative isotropy about horizontal axis A_4 , where A_4 index = black 50°
× 338

THE BANDS OF SCHREGER: THE ROLE OF REFLEXION

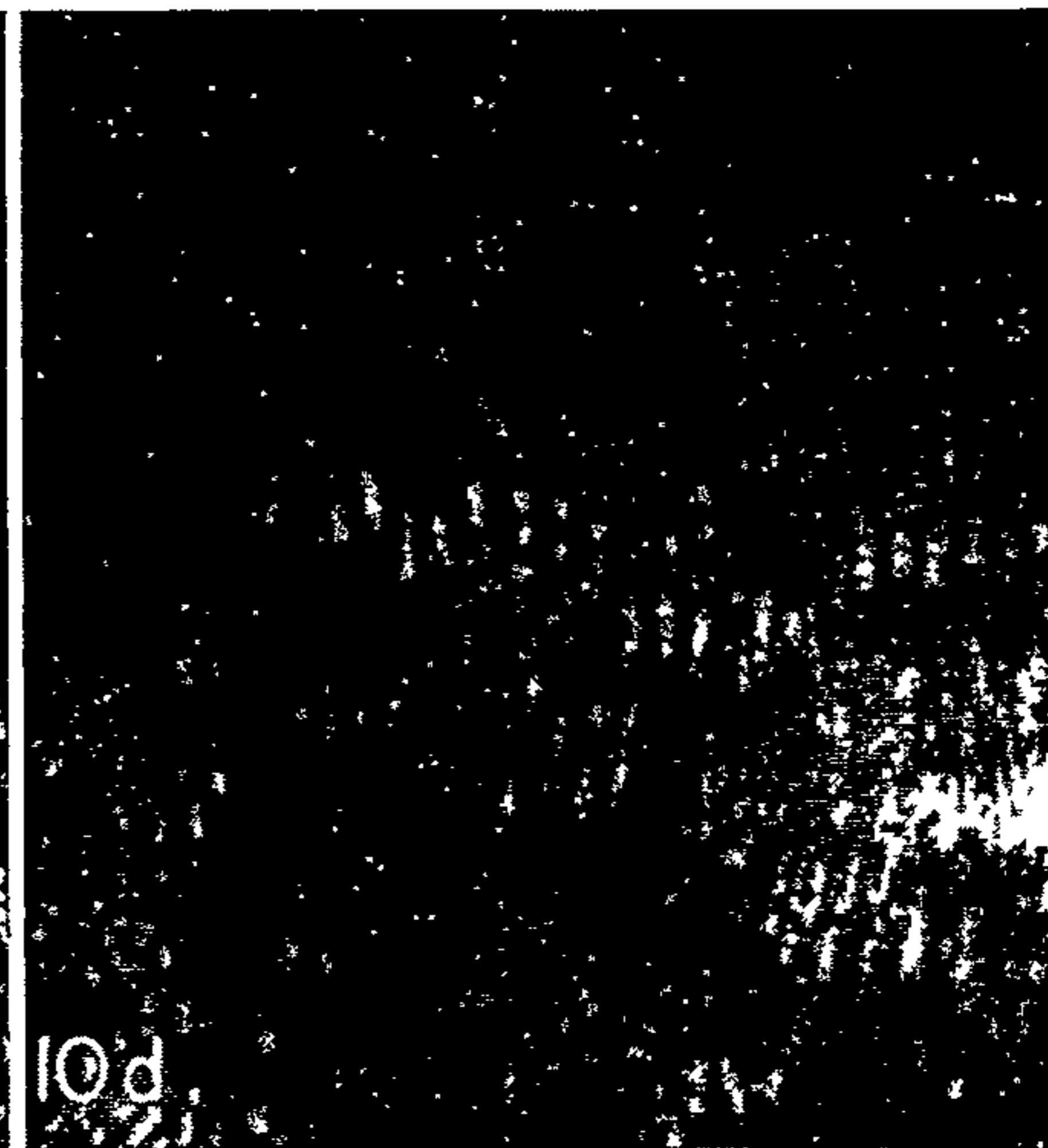
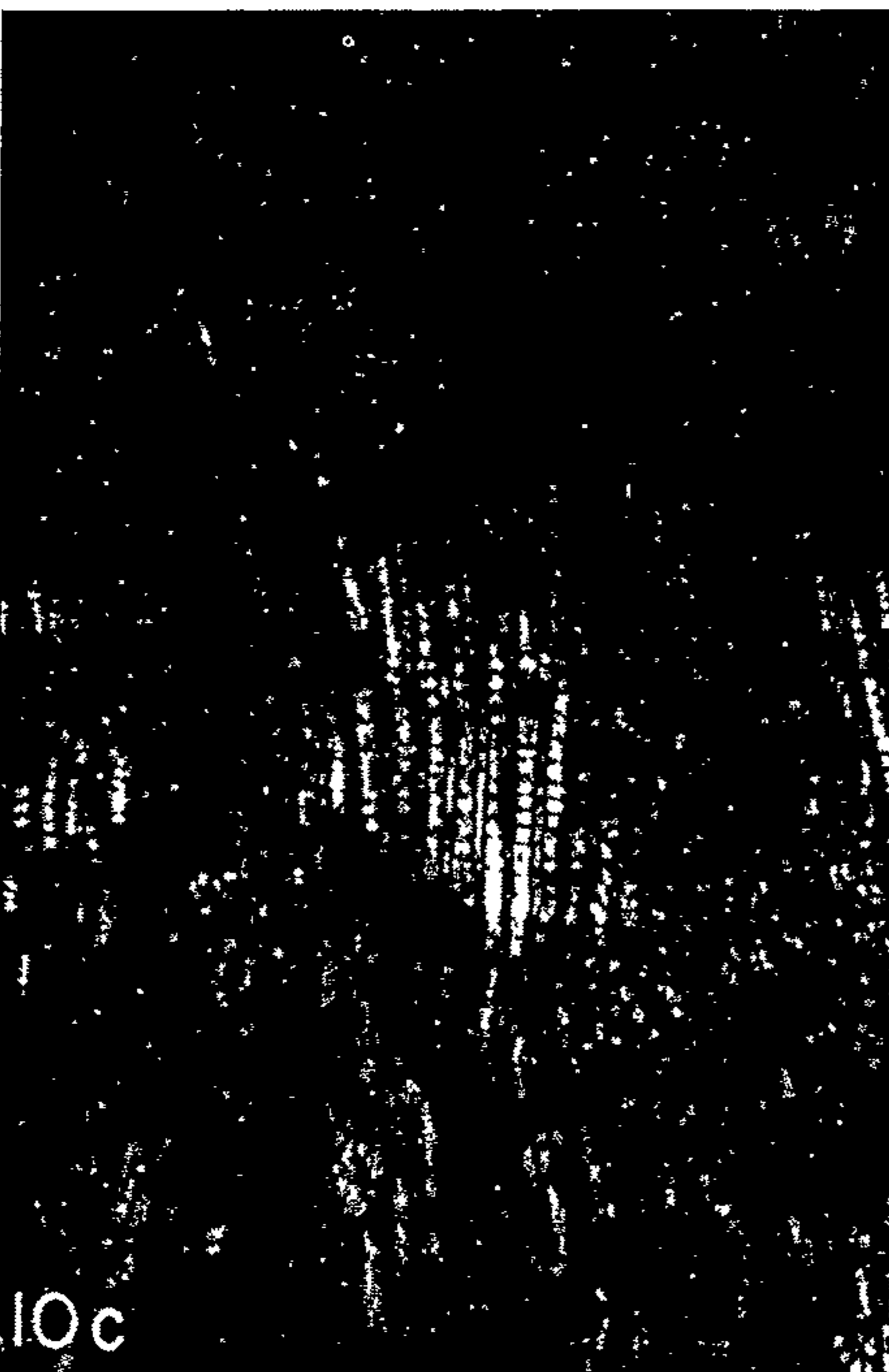
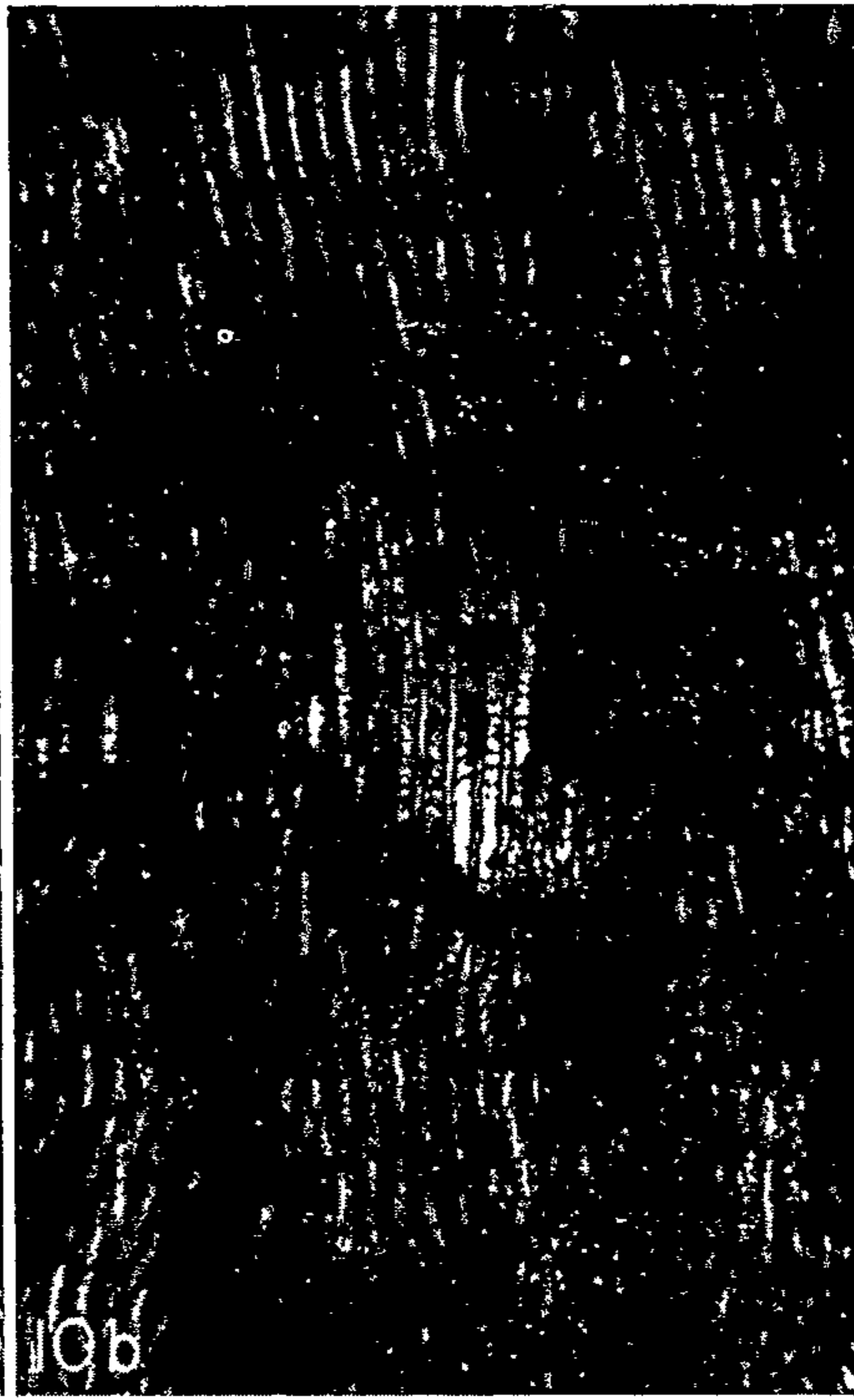
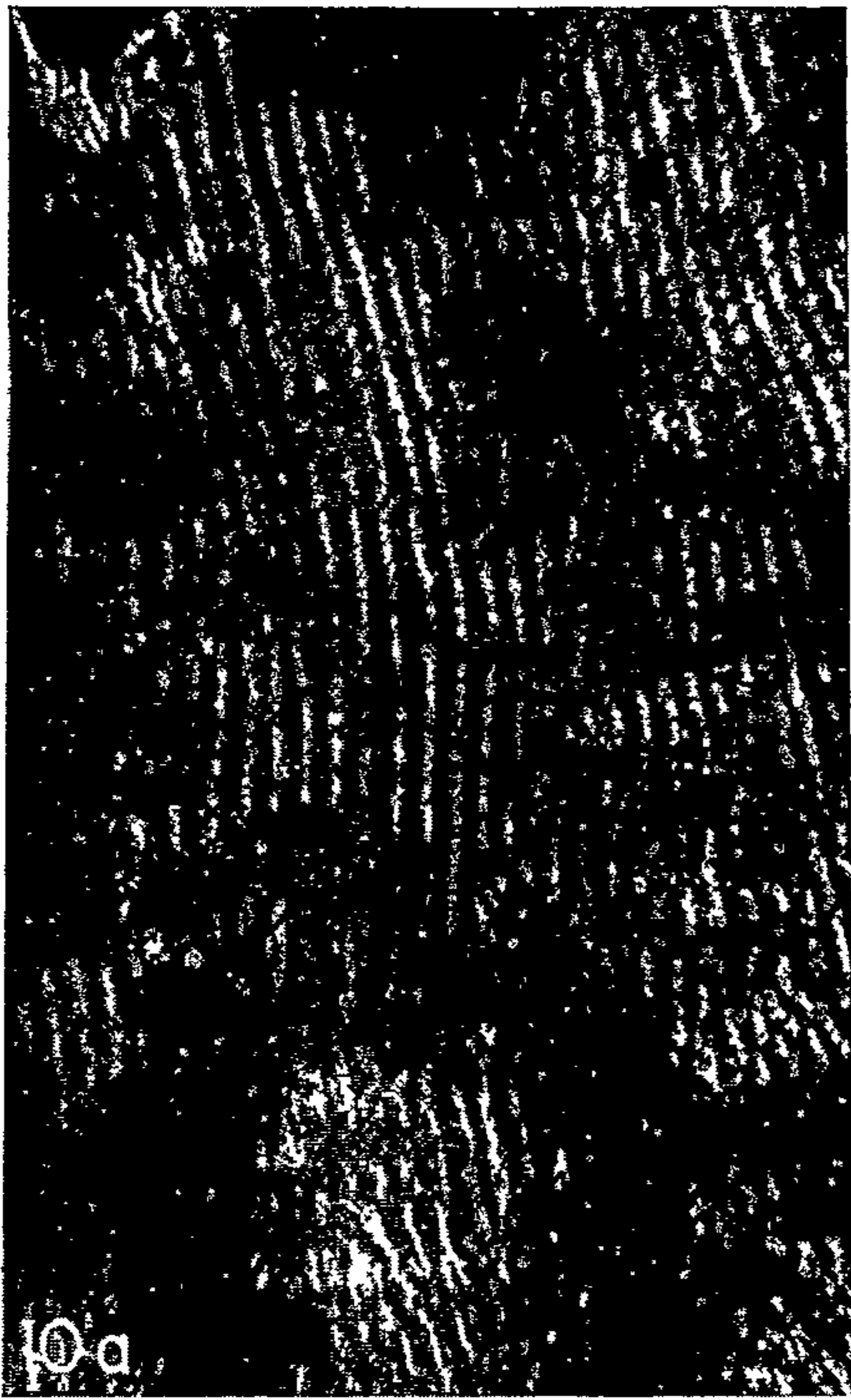

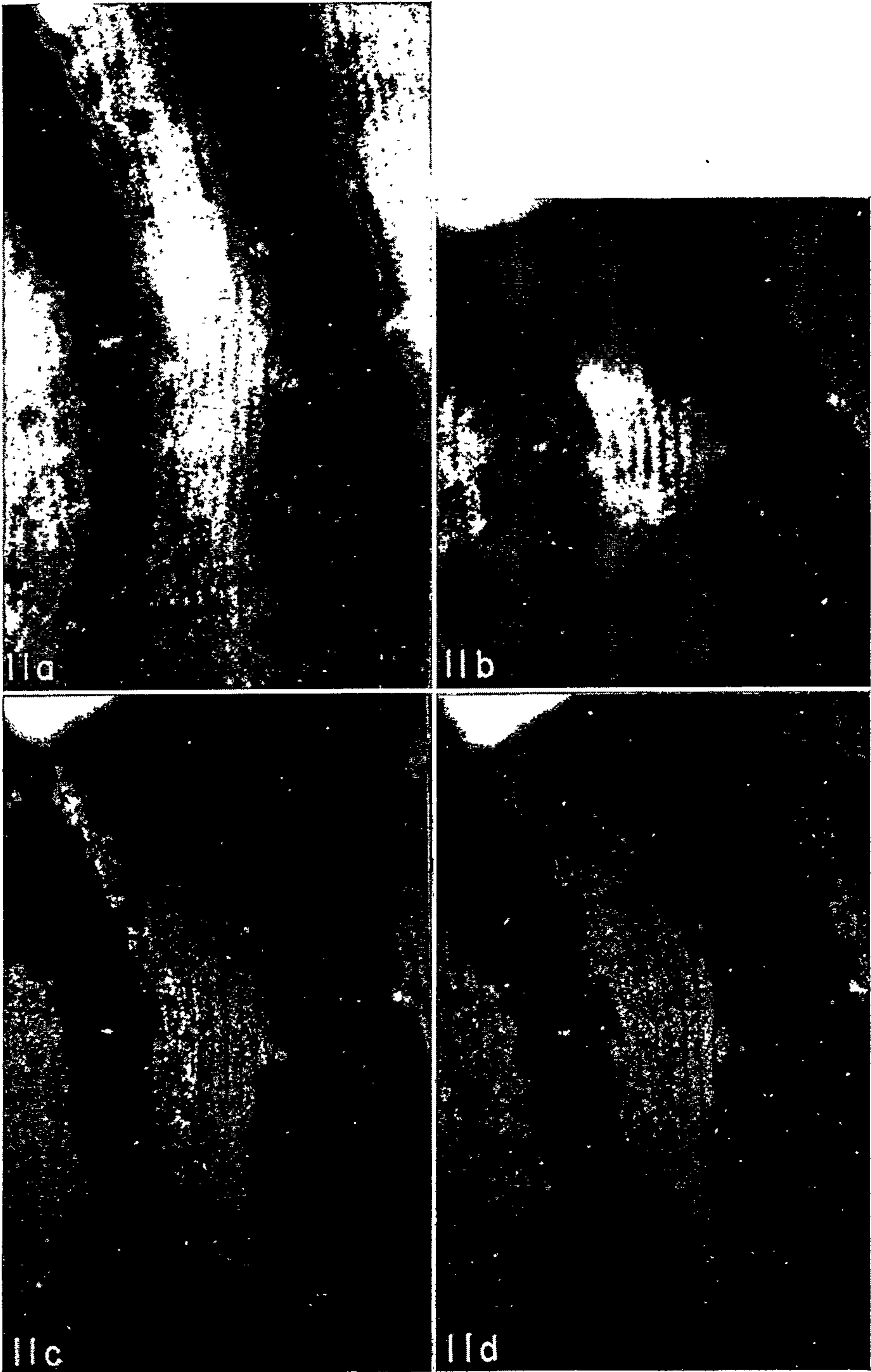

PLATE 8

PLATE 8

FIG. 11. Specimen B under incident light showing the portion of rod group examined in the following positions of maximal brightness:

- (a) with A_3 index fixed at 0° and A_4 index = black 7°
 - (b) with A_3 index fixed at 180° and A_4 index = black 41°
 - (c) with A_3 index fixed at 90° and A_2 index = L.H.S. 15°
 - (d) with A_3 index fixed at 270° and A_2 index = R.H.S. 15°
- × 338

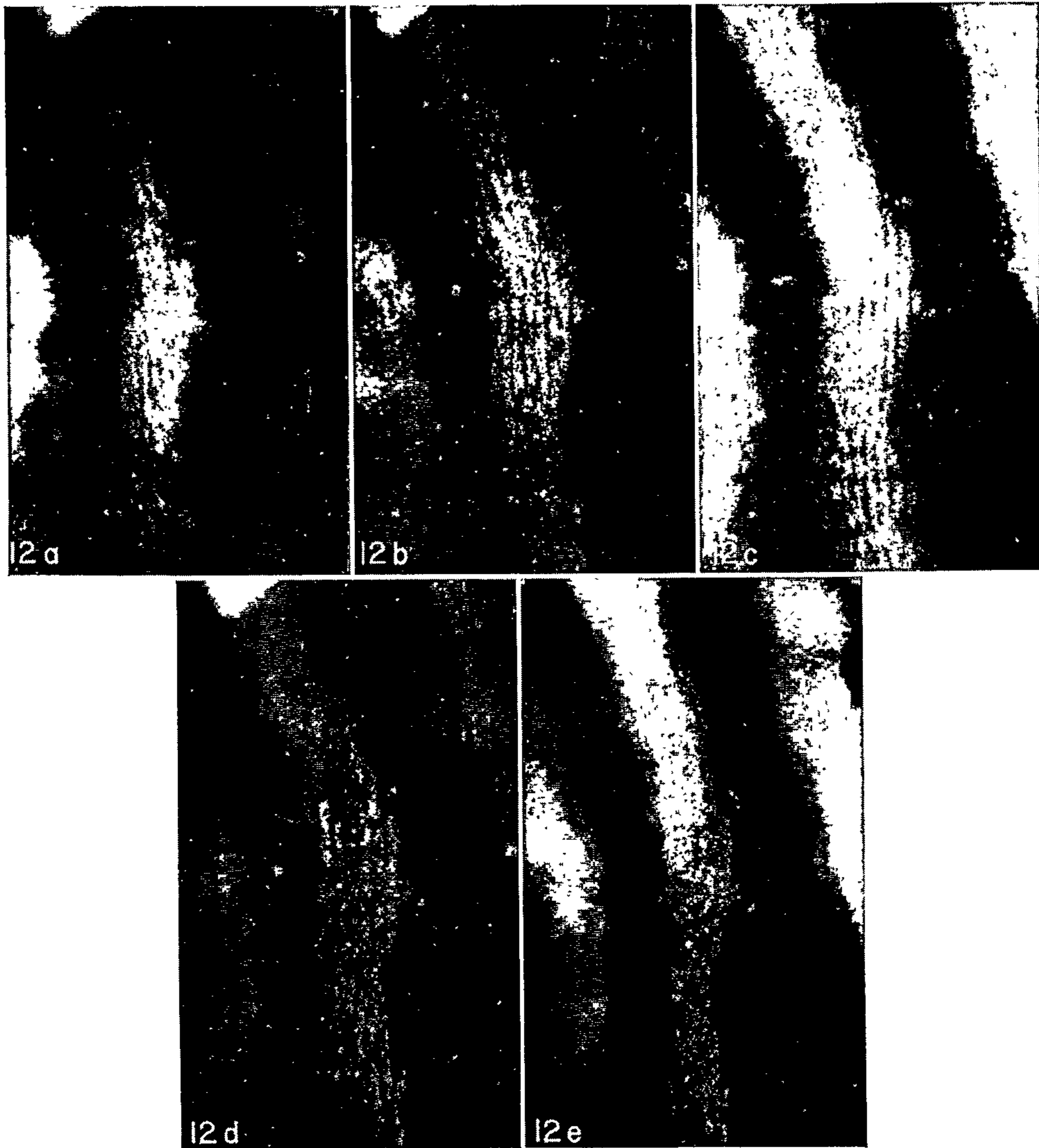

FIG. 12. Rotation of specimen B under incident light about horizontal axis A_2 , from a position of brightness. The A_3 index was fixed at 0° and the A_4 index at black 7° .

- (a) A_2 index = L.H.S. 40°
 - (b) A_2 index = L.H.S. 20°
 - (c) A_2 index = 0°
 - (d) A_2 index = R.H.S. 20°
 - (e) A_2 index = R.H.S. 40°
- × 338

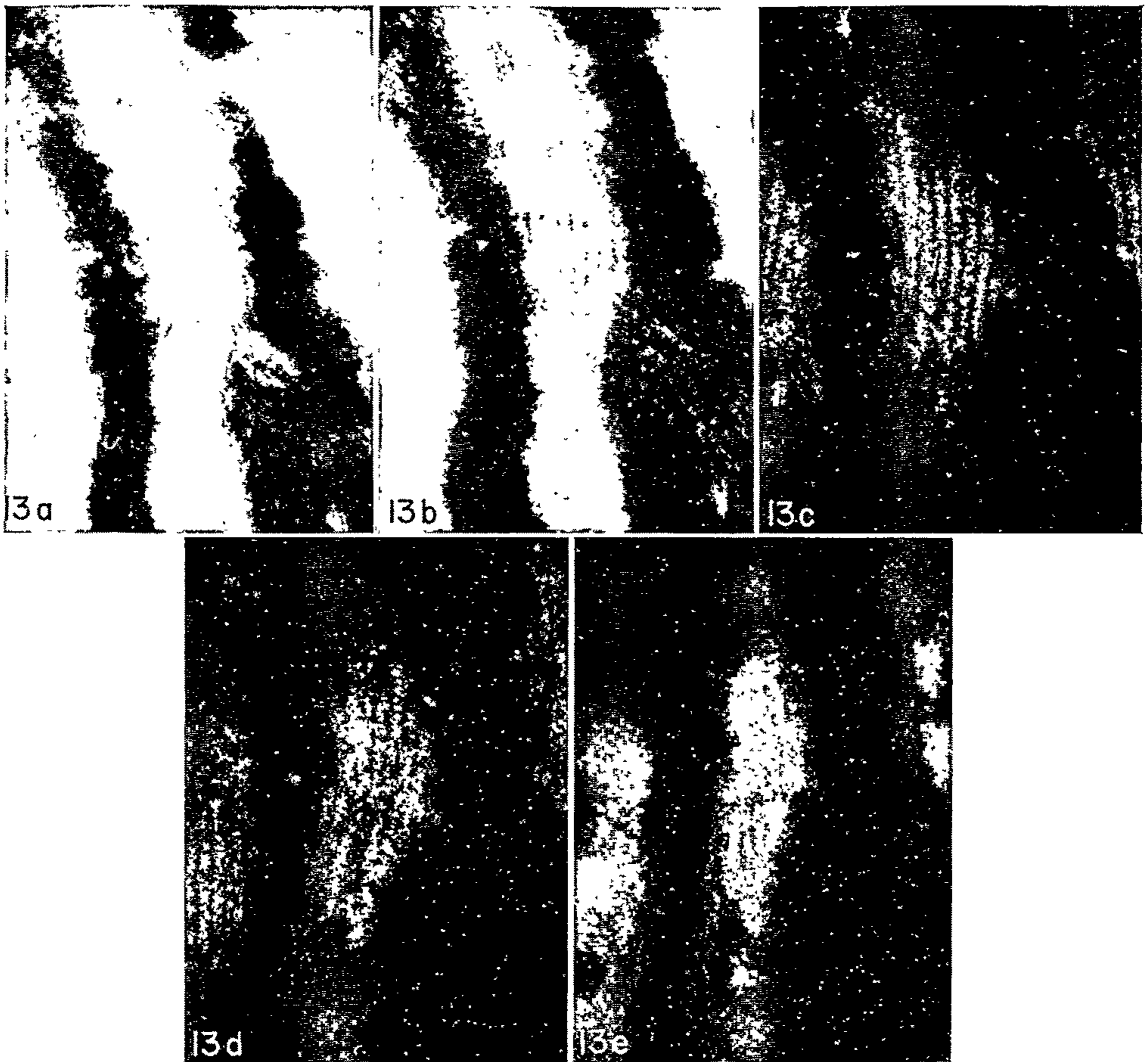

FIG. 13. Rotation of specimen B under incident light about horizontal axis A_4 , from a position of brightness. The A_3 index was fixed at 90° and the A_2 index at L.H.S. 14° .

- (a) A_4 index = red 30°
- (b) A_4 index = red 20°
- (c) A_4 index = 0°
- (d) A_4 index = black 20°
- (e) A_4 index = black 30°

$\times 338$

Reprinted from the Journal of Anatomy (Lond.) 100, 925, 1966.

Light-Optical Effect Associated with
the Decussation of Enamel Prisms:

K.S. Lester, King's College, London.

The Hunter-Schreger bands as seen in polished ground sections of dental enamel viewed by reflected light are known to reverse their appearance with a change in the orientation of the specimen with respect to the light source. The manner in which band reversal takes place was examined by rotating thick sections in a horizontal plane relative to a fixed light source (change in azimuth).

A definite sequence of band appearances was found to accompany complete reversal of the bands. The change in appearance is a very gradual one and involves the apparent splitting, parting and subsequent reformation of the light bands. However, complete band reversal does not always take place with such a rotation, in which case reversal of the original configuration may be completed by changing the incident angulation of the illumination (change in altitude).

By subsequent examination of predetermined areas of very thin

ground sections of dog premolar enamel both by transmitted polarized light and by reflected ordinary light with the aid of a four-axis universal rotating stage, the reflective behaviour of the enamel could be related to the approximate longitudinal axis of its prisms.

It was found that the appearance of the Hunter-Schreger bands in a given area of enamel is entirely dependent upon the relationship of the specimen to the illumination with respect both to azimuth and altitude. While the actual site in the enamel at which the reflexion occurs is still under question, the reflective behaviour of enamel obeys the laws of reflexion with respect to the longitudinal axis of the enamel prisms.

Reprinted from



PERGAMON PRESS
OXFORD NEW YORK LONDON PARIS

