

The University of Sydney

**Copyright in relation to this thesis\***

Under the Copyright Act 1968 (several provision of which are referred to below), this thesis must be used only under the normal conditions of scholarly fair dealing for the purposes of research, criticism or review. In particular no results or conclusions should be extracted from it, nor should it be copied or closely paraphrased in whole or in part without the written consent of the author. Proper written acknowledgement should be made for any assistance obtained from this thesis.

Under Section 35(2) of the Copyright Act 1968 'the author of a literary, dramatic, musical or artistic work is the owner of any copyright subsisting in the work'. By virtue of Section 32(1) copyright 'subsists in an original literary, dramatic, musical or artistic work that is unpublished' and of which the author was an Australian citizen, an Australian protected person or a person resident in Australia.

The Act, by Section 36(1) provides: 'Subject to this Act, the copyright in a literary, dramatic, musical or artistic work is infringed by a person who, not being the owner of the copyright and without the licence of the owner of the copyright, does in Australia, or authorises the doing in Australia of, any act comprised in the copyright'.

Section 31(1)(a)(i) provides that copyright includes the exclusive right to 'reproduce the work in a material form'. Thus, copyright is infringed by a person who, not being the owner of the copyright, reproduces or authorises the reproduction of a work, or of more than a reasonable part of the work, in a material form, unless the reproduction is a 'fair dealing' with the work 'for the purpose of research or study' as further defined in Sections 40 and 41 of the Act.

Section 51(2) provides that "Where a manuscript, or a copy, of a thesis or other similar literary work that has not been published is kept in a library of a university or other similar institution or in an archives, the copyright in the thesis or other work is not infringed by the making of a copy of the thesis or other work by or on behalf of the officer in charge of the library or archives if the copy is supplied to a person who satisfies an authorized officer of the library or archives that he requires the copy for the purpose of research or study'.

\*Thesis' includes 'treatise', dissertation' and other similar productions.

UNIVERSITY OF SYDNEY

A REHEARSAL ANALYSIS OF  
THE PRODUCTION OF  
*THE BLIND GIANT IS DANCING*  
BY NEIL ARMFIELD AND THE  
COMPANY B ENSEMBLE.

THESIS SUBMITTED  
TO THE FACULTY OF ARTS  
IN FULFILMENT OF THE REQUIREMENTS  
FOR THE DEGREE OF  
MASTER OF PHILOSOPHY

CENTRE FOR PERFORMANCE STUDIES

BY  
RUSSELL DAVID FEWSTER

AUGUST 2001

Copyright 2001 by Russell Fewster  
All rights reserved

For my father David Fewster

## ACKNOWLEDGEMENTS

The writer wishes to thank the following: The Centre for Performance Studies at the University of Sydney, his supervisor Gay McAuley for her patience and guidance, colleague Paul Dwyer for his helpful comments, Neil Armfield and Company B for allowing me to document their rehearsal process and actors Peter Carroll, Russell Kiefel and Kerry Walker for reading and providing feedback on this thesis.

## CONTENTS

ACKNOWLEDGMENTS.....	iv
LIST OF ILLUSTRATIONS.....	vii
ABSTRACT.....	viii
INTRODUCTION.....	1
Chapter	
1. HISTORICAL OVERVIEW — THE GESTUS OF BELVOIR.....	4
1.1. Neil Armfield and the Company B Ensemble.....	4
1.2. Aims of this Analysis.....	14
2. METHODOLOGY.....	18
2.1. How to Document?.....	18
2.2. What to Document?.....	24
2.3. Ethnographic Approaches.....	28
(a.) In the field.....	29
(b.) Writing up.....	34
2.4. Schema — What and How to Analyse?.....	36
3. THE FIRST WEEK — A 'COLLECTIVE UNDERSTANDING'.....	41
3.1. The First Reading.....	41
3.2. The Design Presentation.....	49
3.3. The First Run of the Play.....	54

## Chapter

4. ACT 1 'COMPANY SCENES' — MACROSCOPIC WORLDS.....	56
4.1. The 'Train Scene'.....	56
4.2. The 'Party Scene'.....	65
4.3. The 'Accident Scene'.....	72
5. ACT 2 A 'FAMILY SCENE'— 'A DEMOCRATIC FASCIST'.....	75
5.1. The 'Barbecue Scene'.....	75
6. ACT 3 CONFRONTATION BY TWO.....	89
6.1. Allen and Wells Confrontation.....	89
7. ASSEMBLING THE PLAY — 'DRIVING STAGE MANAGERS MAD'...	102
7.1. Running the Play.....	102
7.2. 'Teching' the Play.....	109
7.3. In Performance .....	113
8. CONCLUSION: A DEMOCRATIC PROCESS?.....	119
8.1. Before Rehearsal.....	119
8.2. Alternatives within Tradition.....	126
8.3. Strategies for a 'Creative State'.....	130
Appendix	
1. State Theatre Company of SA Production Schedule.....	143
2. Company B Rehearsal and Production Schedules.....	145
3. Letter from Peter Carroll.....	154
4. Letter from Russell Kiefel.....	157
5. Letter from Kerry Walker.....	159
BIBLIOGRAPHY.....	161

## ILLUSTRATIONS

Figure	Page
1. The blocking for the 'train scene,' Act 1 Scene 3.....	61
2. The blocking for the 'party scene,' Act 1 Scene 6.....	68
3. The blocking for the 'accident scene,' Act 1 Scene 11.....	74
4. The starting positions for the 'barbecue scene,' Act 2 Scene 7.....	78
5. The revised starting positions for the 'barbecue scene,' Act 2 Scene 7.....	80
6. The final starting positions for the 'barbecue scene,' Act 2 Scene 7.....	82
7. Neil Armfield demonstrates the starting positions for Act 3 Scene 1.....	93
8. Hugo Weaving changes the starting positions for Act 3 Scene 1.....	94
9. The blocking changes again — Armfield acts upon a suggestion from Russell Kiefel for Act Scene 1.....	95
10. The final blocked starting position for Act 3 Scene 1.....	97
11. Armfield establishes a choric space.....	107

## ABSTRACT

In 1995 an ensemble of some of the finest actors in Australia gathered together under the umbrella of the Company B Theatre Company at the Belvoir Theatre in Sydney. Under the direction of Neil Armfield the ensemble mounted a production of Stephen Sewell's *The Blind Giant is Dancing* which played in Sydney for three weeks and sold out. The ensemble was created by Armfield who had been inspired by the cultural power of a regular company of actors from his experience with the Lighthouse ensemble at the State Theatre Company of South Australia over a decade earlier. The collective experience of Armfield and the veteran actors he invited to become part of the Company B ensemble represented the major zeitgeist in mainstream text-based theatre in Australia over the last twenty years while the younger actors were part of a new generation fresh from drama school.

I was fortunate to be able observe this rehearsal process in its entirety. How the company produced the work in rehearsal is followed closely drawing from my extensive field notes. This participant/observation method of documenting and analysing rehearsal process in turn draws significantly on comparative techniques in cultural anthropology which includes an opportunity for company members themselves to respond to the documentation of their process. This is framed by an initial historical overview of Armfield and Company B's place within recent mainstream text-based theatre practice in Australia. Armfield's directorial methodology is then placed in a wider context by comparison with the work practices of other Australian and world practitioners and the current shifting boundaries between autocratic and democratic practices in producing theatre are subsequently explored.

## INTRODUCTION

According to Ferruccio Marotti 'theatre has to be contextualized within an anthropological reality to avoid becoming a "tourist attraction"' (in De Marinis 1985: 385) while for Marco De Marinis to 'seek to know' a theatre means to seek to know the 'culture in the anthropological sense in which that theatre exists and is experienced' (1985: 384). For De Marinis such a '*contextual analysis*' seeks to 'organically link' theatres to the 'social realities which accommodate them and which they are a part of' (1985: 384-385). This is not unlike a Marxist approach that seeks to define and analyse culture as a 'signifying system through which ... a social order is communicated, reproduced, experienced and explored' (Williams 1982: 13), although within this 'social order', through the 'enlargement of an anthropological notion of culture', the 'notions of group, subgroup, subculture or minority tend to replace those of classes in conflict' (Pavis 1992: 12).

Within the social order of the contemporary field of Australian theatre it follows that Neil Armfield, the Company B ensemble and the Belvoir Street Theatre represent such a 'sub-group' or 'sub-culture.' While not strictly in 'conflict' with other theatre companies, they nonetheless compete for the same funding and often similar audiences. Patrice Pavis, drawing on Eugenio Barba and Camille Camilleri, argues that actors 'possess a culture which is that of their own group and which they acquire during rehearsal' through a process of 'inculturation' that causes them to 'assimilate the traditions and techniques of the group' — this culture of 'theatrical knowledge' is in turn 'transmitted' by social heredity from 'one generation to another' (1992: 9-15). Studying a theatre culture like that of the Company B ensemble requires recognition of this group culture and an analysis of how the 'inculturated group' is placed into a 'metaculture'<sup>1</sup> by its artistic director, or in Pierre Bourdieu's words how and where it is positioned within the 'field of cultural production' (1993: 6-7). In other words the analyst needs to trace the hereditary culture

---

<sup>1</sup>Patrice Pavis states that 'the metacultural aspects refer to the commentary a given culture can make on other cultural elements, when explaining, comparing and commenting on it' (1992: 21).

of the director and principal actors and examine how they have articulated their 'theatrical knowledge' to audiences, the media and to the theatre industry as a whole.

Examining how Neil Armfield and the Company B ensemble have positioned themselves is in a sense to investigate how the group's work reflects what happens in the rehearsal room within the 'institutional framework' of the theatre company itself which 'authorises, enables, empowers and legitimizes' the production of theatre (Bourdieu 1993: 10). The 1995 production of the *Giant* by Company B was articulated by Armfield as being an example of ensemble theatre — the implication being that the social order between himself and the actors was more democratic than regular mainstream rehearsal practice (1996: 7). For Armfield this approach drew from his own 'deepening appreciation of how Shakespeare's company worked.' That is,

the way the parts fits the actors' [reflects] a balanced group of personalities [and overall] the world of the play is a microcosm of what the company [is]. (in Waites 1994: 23)

Kurt Weill and Bertolt Brecht argued that social order on stage is revealed on a micro-level by the 'attitudes adopted by the speaker towards others, by a gestic language grounded in gest' and on a macro-level by 'social gest' which is the 'mimetic and gestural expression of the social relationships prevailing between people of a given people' (in Willett 1964: 104 & 109). It interests this writer to explore how the work on stage and in the rehearsal room also reflects or embodies the social world within the production team itself; how artistic outcomes are determined by the social 'attitudes' and structure of the group that produces the play — the 'play within the play' in English actor Simon Callow's words (1984: 177).<sup>2</sup> In order to understand the working relationship between the Company B members the gestic language and social gest of the group needs to be identified. This company culture in turn needs to be studied on both micro and macro levels: both within the theatre event, itself and in the broader context of what went before and came after.

For Brecht the idea of the *gestus* reflected the Marxist view that society is constantly changing and not fixed and thus needs to be historicised. This is also echoed today by cultural

---

<sup>2</sup> Simon Callow talks about 'the visible rehearsal [as] the objective correlative of the actual rehearsal which is going on some inches below the surface' and which reflects the relationships developed between the actors over the course of rehearsal (1984: 177).

anthropologists, like James Clifford who remind us that cultures 'do not hold still for their portrait' but are ever changing (1988: 10). Similarly Peter Brook has described his own work in theatre as following a constantly 'shifting point' of attention (1988: xiii). Cultures and the theatre they produce are inevitably linked and therefore both always on the move. Erwin Piscator, a contemporary of Brecht, remarked that theatre is dependent upon the 'society of the day' and the economics of the day and the director must 'fix the point that is common to him and to the decisive, formative forces of the epoch' (1980: 133).

It is somewhat of an irony to attempt to 'fix' the culture of a theatre group when, in Brook's words, the work it produces is by its very nature 'ephemeral' (1968: 144). Then again perhaps it is even more important to try to do so in order that the particular work of a theatre group can be measured and placed into some sort of perspective by reviewing its place within a historical continuum. In director Jim Sharman's words:

Without access to history the growth of our theatre is inhibited [and] such an absence of tradition can be wasteful as each new generation sets about reinventing the wheel. (1995: 10)

This could be seen as a warning perhaps to both practitioners and academics. Therefore in order to frame and contextualise a theatre rehearsal analysis it would seem useful to first give a historical overview of the theatre company producing the work: to situate the Belvoir theatre, the Company B ensemble and its artistic director Neil Armfield within a cultural and social setting, that is, to identify the social gestus of all three within recent Australian theatre history.

## 1. HISTORICAL OVERVIEW - THE GESTUS OF BELVOIR

### 1.1. The Company B Ensemble, Belvoir Street Theatre and Neil Armfield.

In putting together Company B's 1998 season at Belvoir Street, Artistic Director Neil Armfield noted with interest how close the company had come to fulfilling its founding 'goals set in 1984.' Although this was not a 'conscious intention,' the 1998 season would contain radical interpretations of the classics; contemporary hard-edged Australian theatre; work by aboriginals and women — the core of a 'list of dreams' created in 1984 through an 'exhaustive workshop process.' It would be a diverse season that promised subscribers 'six fresh, challenging and extraordinary nights in our theatre' (1998: 11). Noticeable for its absence was the Company B ensemble. Yet two years earlier, in launching the 1996 season, Armfield had cited 1995 as a wonderful year where they had 'gathered together the Company B Ensemble, a family of great actors moving from show to show growing and developing together' the culmination of which was the 'exhaustion and exhilaration' of a national repertory tour of *Hamlet* and *The Tempest* (1996: 7). Armfield's greatest thrill in 1995 though had been the 'queues of people of all ages, all social backgrounds waiting to get into' the ensemble's production of *The Blind Giant is Dancing*, a "difficult play" that sold out' (1996: 7).

However over 1996 the ensemble would be less continuous and by 1997 the Company's production of Chekhov's *Seagull*, arguably an ensemble vehicle,<sup>3</sup> would contain just four of the original Company B ensemble members: Cate Blanchett, Ralph Cotterill, Gillian Jones and Richard Roxburgh. Speaking in 1996 Armfield stated that already he didn't refer to Company B as 'an ensemble' any more but rather like a 'family' that had 'grown up together' (in Phillips: 33). This 'family' was now, according to Armfield just one of a series of families that he had set up to live and work within the performing arts industry as he freelanced between Company B and opera. The Company B ensemble was, one could surmise, like a family whose members had grown up together and then left home to variously work with

---

<sup>3</sup> The English director Peter Hall has described Chekhov as a 'particularly wonderful ensemble-maker' in the equity of 'roles in his plays' (in Miles 1991: 205).

other theatre companies, pursue international film careers (Geoffrey Rush and Cate Blanchett) or become a lecturer in acting (Gillian Jones) at the Western Australian Academy of the Performing Arts (W.A.A.P.A.).

One of the difficulties that is often cited in maintaining an ensemble of actors in Australia is that film offers actors both a much greater financial reward and more international exposure than theatre can. In addition the English director Peter Hall has commented that ensembles have a natural life of 'three years' followed by an 'inevitable cycle of creation and death' as actors come and go (in Miles 1991: 203). The Company B Ensemble would seem to have formally endured for even less, for only two years. However this is not surprising as, historically, theatre ensembles and/or smaller theatre companies that offer an alternative vision to State Theatre Companies in producing text-based theatre in Australia have been relatively brief affairs. The Australian theatre scene of the last decade is dotted with such companies that have fallen by the wayside due to actor turnover, increasing funding pressure and/or loss of artistic direction.<sup>4</sup>

The importance of the work produced by these companies to the development of Australian theatre is undeniable, through variously promoting new Australian plays, innovative overseas plays, fresh approaches to Shakespeare and group devised work.<sup>5</sup> Equally important are the rehearsal processes that have created such alternative work — processes that have reflected attempts to subvert the 'machine' like demands on rehearsal time in mainstream theatre for a more 'organic' process and which constitute a search for a democratic ideal where perhaps an ensemble of actors has a greater input than normal into the creative decisions within rehearsal (Minchinton 1998: 139).<sup>6</sup>

---

<sup>4</sup> For example ensembles included the Lighthouse Theatre Company and the Red Shed (S.A.), The Performance Syndicate and The Sydney Front (N.S.W.). For Paul McGillick the 'absence of critical support and documentation and the failure of mainstream theatre to feed on experiment' has contributed to the demise of these companies (in McCallum 1995: 218).

<sup>5</sup> For example The Lighthouse ensemble, based at the State Theatre Company of South Australia (S.T.C.S.A.) from 1982-83, premiered not only four European classics to Adelaide audiences but four new Australian works as well, including *The Blind Giant is Dancing*.

<sup>6</sup> According to Mark Minchinton, Rex Cramphorne (1941-91), who directed around ninety productions in Australia and formed his own actor ensembles, 'subverted the idea of the mainstream theatre director.' Minchinton comments that Cramphorn

Paul McGillick writing in *The Companion to Australian Theatre* has lamented a lack of 'continuity of experiment' in theatre in Australia and in Sydney in particular. He uses the Nimrod Theatre Company as an example of a perceived 'general failure' of smaller theatre groups to 'develop a coherent and articulate aesthetic' within which to position their otherwise admirable work (in McCallum 1995: 218). The development of such an aesthetic, articulated by Armfield to support the stage work at Belvoir Street is interesting to follow as Company B evolved towards an ensemble structure. Company B in fact had its origins when The Nimrod Theatre Company moved from Belvoir Street Theatre to the Seymour Centre, where it eventually came to an end, after fifteen years existence and was the last of the experimental companies of the 1970s (1995: 407).<sup>7</sup> The Belvoir Street Theatre was saved as a venue in 1985 when a co-operative of six hundred people bought the theatre in what Armfield called a 'a singular act of faith' (1998: 10). For the first two years there was a 'miscellany' of work leading to the widely held perception that Belvoir Street did not have a stable artistic identity (Nowra 1988: 6). In order to co-ordinate the artistic planning while the administrator Chris Westwood ran the theatre, Armfield became artistic counsel in 1988 introducing a subscription season. He subsequently became artistic director of Company B, a resident production company distinct from the theatre it operated within.

Armfield's 1994 ensemble production of *Hamlet* for Company B was seen by both Armfield and the general manager, Louise O'Halloran, as a major 'turning point' both artistically and financially (in Litson 1995: 80). O'Halloran in fact stated publicly that the Company had nearly gone 'bust' prior to this production, while for Armfield it prompted his decision to form a Company B ensemble which would be the core of the company's activities in 1995. He explained in May of 1995 that establishing an ensemble was an 'attempt to declare a tradition of work' that was 'palpable'

---

refused to take an overt directorial role, preferring to involve all the cast, the designer, and sometimes the technicians, in decisions about staging, setting, costumes, texts and so on. (1998: 131)

<sup>7</sup> Nimrod according to John McCallum 'did much of the work in decolonising Australian theatre and its 'spirit continued to be felt in the work of Griffin Theatre Company and Company B Belvoir in the late 1980s and early 1990s' (1995: 407).

and could 'inspire others' (in Litson 1995: 80).<sup>8</sup> Armfield in fact admitted that the company's previous 'eclecticism' had been both a 'strength and a weakness' and that although he knew where he was 'going' artistically from show to show he was concerned that audiences wouldn't. By forming an ensemble he was hoping to 'focus' the company's work and throw a 'net' around an idea that had for him been long developing (in Litson 1995: 80).

For Armfield the creation of the Company B ensemble had its origins in Jim Sharman's Lighthouse Theatre Company in Adelaide where he worked in the early 1980s.<sup>9</sup> Armfield was inspired by Sharman's productions of Patrick White's plays, which 'hit [him] between the eyes and showed [him] what theatre can do' (in Litson 1995: 80). For Armfield the creation of a continuing ensemble of actors had magically transformed the performance of Australian drama:

They were pieces of theatre that had a sense of everyone on stage fusing with something that was so true and powerful that you had quite a different experience compared with most productions. (in Litson 1995: 80)

Armfield, in an attack on what Mark Minchinton has termed 'majoritarian theatre',<sup>10</sup> argued that the Company B ensemble

---

<sup>8</sup> Armfield cited a 'significant tradition of work developing' that included: *The Tempest*, *Diary of a Madman*, *No Sugar*, *The Master Builder*, *Aftershocks* and *Dead Heart* amongst others (in Litson 1995: 80).

<sup>9</sup> Lighthouse was established by Jim Sharman within the State Theatre Company of S.A. from 1982-83. The Melbourne theatre critic Leonard Radic writes that it was 'in some ways the most important' theatrical alternative within the mainstream in the 1980s. It was a

fixed company of 13 actors all of whom where possible would be engaged in each of the year's productions. Sharman did not like the State Theatre Company model he wanted a new one where the writers were more closely involved with the actors and directors. (1991: 182-183)

<sup>10</sup> Mark Minchinton who worked as an actor with Rex Cramphorn uses Gilles Deleuze and Félix Guattari's definition of a 'major' language or literature as a way to describe the mainstream theatre rehearsal practice of State Theatre Companies (1998: 128). Deleuze and Guattari define a major literature as the product of a country's major language. In describing Franz Kafka's work they argue for a 'minor literature,' born from Kafka's knowledge of the Czech language and Yiddish and which can create 'revolutionary conditions' within a major language such as German. (They give another example in the current use of the English language by the blacks in North America.) 'Since the language is arid, make it vibrate with intensity' (1986: 16-27). Armfield one might argue sees the mainstream master-director practice as similarly 'arid' and in need of revolutionising through the relatively minor practice of ensemble-based rehearsal and performance.

would be able to create productions with a similar 'unifying vision' that many contemporary productions lacked — a 'fusion into one world' — rather than seeing on stage 'different stratas of salary' (in Litson 1995: 80). Armfield was arguably signalling a partial subversion of what Minchinton calls 'the idea of the mainstream master-director' for a more democratic ensemble-based process (1995: 128). In a broader sense the ensemble would also give the company a visible and tangible sense of being that would go beyond individual productions. Specifically Armfield wanted it to confirm the company's 'approach to acting and production' over the last decade and which he thought had been a 'profound cultural experience' that was particularly 'Australian in language [and] sensibility of performance' (Letter to Subscribers 1994).

All the actors that Armfield invited to be part of the ensemble agreed to join the company and the majority had worked with him before on numerous occasions.<sup>11</sup> In forming the ensemble Armfield had also proclaimed publicly a loyalty to a group of actors, who in return had articulated publicly their commitment to Armfield's vision, thereby enhancing it as a valid alternative to majoritarian theatre. Richard Roxburgh, who played *Hamlet* in Armfield's production, noted at the time that the creation of the ensemble was 'the most exciting development in Australian theatre in years' and that it was a triumph of 'art' over 'industry' (in Bonney 1994: 8). Roxburgh himself had set up the Burning House ensemble (another that has now fallen by the wayside) because he wanted to create a new wave of Australian theatre being done in an uniquely 'Australian way.' For Roxburgh this meant recapturing the 'great energy' and spirit of Nimrod. It referred specifically to the notion of ensemble creation and playing — a hands on approach where 'all the creative elements' (including set, costume and sound design) were used by 'everyone' from an early stage, resulting in greater creative 'satisfaction' and ownership, thereby 'empowering' the actor (in Bonney 1994: 9).<sup>12</sup> This contrasts with the State Theatre Company model that dictates by pure logistical and financial necessity that set and

---

<sup>11</sup> Kerry Walker for example had worked with Armfield on twenty previous productions.

<sup>12</sup> In Burning House's production of *That eye, The Sky* 'They [the ensemble] created the atmosphere [through] cricking as cicadas, squarking as ... chooks, or creating the ripples of a creek' (Bonney 1994: 9).

costume design must be in place before the actors begin rehearsal.<sup>13</sup>

Both Roxburgh and Armfield referred to an idealised theatre that proclaimed a unique 'Australian' playing style. While attempting to define such a generic term is problematic, its origins can be traced back to the early 1970s, in the days of Nimrod in Sydney and the Australian Performing Group in Melbourne, where actors and audiences alike were first encouraged to appreciate both the 'comic and poetic' in the Australian vernacular in the performance of Australian plays (Rowse 1985: 70). According to Leonard Radic it was 'a vigorous language that was matched by the sheer vitality, exuberance and energy of the playing' that contrasted markedly with the prior emphasis on 'English-style refinement' and accent (1991: 4). In addition to the freshness of the language and performance style were the Nimrod and La Mama theatres themselves which, like Belvoir Street Theatre, were small intimate venues which 'made possible a new informal relationship between actor and audience that was both immediate and direct' as against the distancing 'fourth wall' of the traditional proscenium arch (1991: 5-6). Theatres like La Mama also gave artists something that was 'virtually unobtainable elsewhere in the country ... [an] opportunity to engage in a dynamically creative relationship with a professional ensemble' (1991: 5-6). It is the latter two factors that perhaps relate most strongly to Armfield's recent work at Belvoir: an ensemble in residence in one of these 'irregularly shaped pocket playhouses,' together with an accompanying sense of a more egalitarian rather than a traditional, autocratic, authorial, directorial approach, facilitating in turn a greater input from the actors (1991: 6). For example actor Kerry Walker said at the time of the founding of the Company B ensemble that working with Armfield meant that while the 'vision' remained his, there was a 'real sense of democracy' in the process (in Litson 1995: 80).

The Company B ensemble would be much acclaimed by the industry, critics and audiences alike; it would produce five works, *The Tempest*, *Hamlet*, and *The Blind Giant is Dancing* over 1994-1995, *A Night on Bald Mountain* and *The Alchemist* in 1996, before it largely dissolved and Company B reverted to its present day structure in which each production is cast separately.

---

<sup>13</sup> For example a 1980s information flyer from the State Theatre Company of SA outlining the Company's standard production schedule has the design concept finalised 20 weeks before the opening night (See appendix 10.1).

Although Armfield was able to argue for an aesthetic that supported the ensemble's critically acclaimed stage work, actor turnover would seem to have been the principal reason for the ensemble's demise. And while high profile actors from the ensemble such as Cate Blanchett and Geoffrey Rush would return to launch subsequent Company B seasons the ensemble would now seem to have been a short, intense and bright light in the Australian theatre scene, that was unable to be sustained.

In the 1998 Company B programme, Armfield highlighted the following sentence:

For me, Company B is the corner of the Belvoir space.

This suggests that in the absence of a stable ensemble, Armfield locates Company B's continuity spatially, in the idiosyncratic theatre architecture of Belvoir Street, rather than in the bodies of his actors. Or is this simply Armfield, the artistic director trying to articulate what is special about his company in a changing world? He continues:

It just seems to contain a story so well, it's like the spine of a book ... with the actors those characters.

It is now the performance space, rather than the actors, that creates the unique Company B spirit, its way with stories, an apparent shift from Armfield's critical positioning of what sets Company B apart from other historically alternative theatre companies; that is, a shift away from a sense of an ensemble to a privileged sense of space. However on closer examination one can argue that the physical limitations of the company's theatre, both the performance space and the dressing room, were always invariably linked with the development of an ensemble at Belvoir.

Armfield, in talking about the ensemble's 1994 production of *Hamlet*, directly acknowledged that:

At Belvoir Street I think the notion of wage parity and I suppose a single dressing room, does very much affect what's communicated from the stage to the audience.  
(in Golder & Madelaine 1995: 73)

Armfield goes on to say that for that production of *Hamlet* the company talked about a 'way of [formally] presenting the play through a shared moment of presenting all the actors.' This was achieved through a prologue spoken by Horatio with the whole

cast watching on stage. This implies that on stage, as in the dressing room, there is no hierarchy of actors; there are no separate dressing rooms and by inference no star system either — a point reflected by Kerry Walker's comment to me that 'everyone no matter what their role, gives a hundred percent' to supporting each other. One could argue that even without an official Company B ensemble any more, wage parity, and a shared dressing room in particular still encourage an ensemble-like atmosphere within any cast who must change and prepare for a performance, like a poor family using the same bedroom. In fact Armfield has argued for both an intimate sense of sharing between performers on stage and between performers and the audience — the latter being enhanced by treating the audience as if they're in 'our living room' and gazing into a performance space 'where people and behaviour are cornered and highly focussed' (in Phillips 1996: 32).

Armfield's 'trajectory' through the history of Belvoir involves a series of what Pierre Bourdieu calls 'position-takings' or the 'space of creative works ... both internal (e.g. stylistic) and external (e.g. political)' (1993: 17). Armfield and Company B in a sense have gone full circle in returning to a subscription season, that accentuates diversity while fulfilling certain identified needs in a particular performance space. Politically within the field of text based theatre, Armfield has been well aware of the need to argue the difference between Company B and their principal rival the Sydney Theatre Company — a field that in Jim Sharman's words reflects a 'national pattern of dramatic activity' which includes a 'mainstream theatre company' and 'strong alternative theatre company' in each capital city and smaller companies serving specific audience needs (1995: 12). During the rehearsal of the *Blind Giant*, Armfield joked that the difference between 'us' and the 'S.T.C.', was that the floor of the stage would be painted in a 'crappy black finish.' Armfield's seemingly facetious throwaway comment reflects the frustrations of Company B's, by comparison to the STC, limited budget. It also perhaps reveals a deeper meaning, the equivalent of Bourdieu's 'economic world reversed', that is, the foregrounding of the 'symbolic' and 'cultural' value of a poor theatre where the comparative absence of economic capital can even ensure greater symbolic prestige and greater recognition of cultural knowledge (1993: 7). For example the foregrounding by critics of an alternative company like Company B's ability to achieve high artistic values despite limited economic resources; the traditional cultural high ground of alternative theatre: rough, in your face, actor-based theatre as evidenced by La Mama and Nimrod in their halcyon days.

That Armfield has attempted to position Company B as a genuine alternative theatre company is evidenced by his comment during the rehearsal of the *Blind Giant* about the frustration of 'trying to change the culture at Belvoir but get[ing] labelled mainstream.' It is important to note that while Armfield may try to position Company B as an alternative within the field of text-based theatre, non text-based theatre practitioners and their critical supporters tend to position all text-based practice as mainstream within the greater field of contemporary performance practice (McAuley 1996: 144-145). Armfield would refer to the notion of a 'Belvoir culture' several times in rehearsing the *Blind Giant*, and this was reflected in his description of the first run of the first act as showing 'a behavioural way of feeling, a *Belvoir* [italics mine] feeling of surrounding the action and seeing the detail'; an emphasis on the play 'growing' in rehearsal where the big picture of the play was as important as the detail and which 'grew' from the 'concentration' the actors 'brought' to the play. Artistically this is what Armfield has argued politically: a 'Belvoir culture' emphasises the actor as storyteller in performance 'within', as actor Peter Carroll states, 'the known limits' of the 'permanent structure of the Belvoir acting space' (See Appendix 11.2.).

According to Frederik Barth:

"Culture" is increasingly used in public debate to define an arena for contesting discourses on "identity" ... and such discourses allow leaders and spokesmen to claim that they are speaking on the behalf of others. (1995: 65)

Certainly Armfield has used the idea of a 'Belvoir culture' to claim the alternative identity in the field of mainstream text-based theatre in Sydney and by touring nationally, in Australia as well, whether it be a privileging of program, ensemble, playing style and/or performance space. 'Difference' in culture, Barth argues, cuts short an account of what others are thinking and doing. The foregrounding of what is 'special' about one's own culture against that of 'the other' leads to 'exoticising, mutilating through a partial rendering of the other's point of view' (1995: 65). For Armfield the emphasis has invariably been on what Company B can, and by inference, what its rivals can't, do.

The Company B ensemble is an example of what an 'alternative' company can do periodically in recent Australian theatre history: allow a group of actors to work and grow

together. The ensemble was recognised as having what sociologist Pierre Bourdieu calls high 'symbolic' and 'cultural capital'/power, that is, the 'accumulated prestige [and] celebrity' of both the director and the actors and their 'cultural knowledge [and] competence' — 'competence' being the ability to 'decipher ... cultural artefacts', to possess 'the code into which it [a work of art] is encoded' (1993: 7). This competence was recognised in both the critical acclaim and popular support that the ensemble achieved in its short life. This did translate into increased economic capital but not enough however, to sustain the ensemble. Interestingly enough funding for Company B from the Australian Council has steadily increased since the ensemble's demise. One might speculate that the popular and critical recognition that the ensemble brought to the company has flowed on and contributed to the subsequent economic success of the company. The recent Australia Council supported tour by Company B to Europe has arguably further enhanced the company's cultural and symbolic power on, now, a world stage.<sup>14</sup>

---

<sup>14</sup> *Cloudstreet* directed by Neil Armfield was rated the best overall international production at the 1999 Dublin Theatre Festival. The Guardian described the production as 'an extraordinary achievement staged with breathtaking panache, a vivid epitome of Australian post-war experience' (in Litson 1999: 17).

## 1.2. Aims of this Analysis

'Experimental [theatre] activity' has been defined by Paul McGillick as containing three key 'elements — individuals, groups and spaces' (in McCallum 1995: 218).<sup>15</sup> If one considers that Company B is no longer a stable ensemble, in addition to the Belvoir Street Theatre the other remaining constant is Armfield himself — Armfield who started work as a director at Nimrod followed by Lighthouse is arguably a strong inheritor of alternative text-based theatre practice in Australia; his 'social formation' has enabled the 'accumulation through a ... process of acquisition and inculcation' of 'cultural knowledge' of such theatre practice (Bourdieu 1993: 7). Particularly important was his first-hand experience and knowledge of how supportive the Lighthouse ensemble had been to the directors, writers and actors that worked within it and the resultant cultural and symbolic power of the work produced. He is also well versed in the mainstream 'other', in this instance the state theatre companies of SA & NSW, having directed for both. Thus having worked in both mainstream and alternative companies (and in Lighthouse which was an alternative model within a mainstream company) he is well placed to construct, or at least to be aware of, the working structure that suits him and the 'family' of artists he attracts around him both within the rehearsal room and within the Belvoir company structure as a whole.

To analyse the rehearsal process of the Company B ensemble is implicitly to analyse Armfield's practice itself — Armfield as artistic director of the company and director of the production would ultimately be responsible for the success of both. Deciding what elements of the rehearsal process to study, or the 'boundaries of rehearsal' is problematic and will be dealt with in more detail in the following chapter (McAuley 1998: 79).<sup>16</sup> However Armfield's rehearsal process, like that of any director, can be examined on at least three levels including: the effect of

---

<sup>15</sup> McGillick defines experimental theatre as theatre that offers an alternative way of working compared to mainstream practice, whereas for the purposes of this analysis I will refer to the same thing simply as alternative theatre, with an emphasis on alternative text-based practice.

<sup>16</sup> Gay McAuley for example has pointed out that 'many important creative decisions' happen prior to the rehearsal between director and actors, such as 'the director's work on the text, ... the formulation of the project for presentation to funding bodies, the casting process itself,' etc.

the institutionalised structure that the director works within; the director's division of time and labour; and third the strategies that the director behaviourally embodies in rehearsal to achieve the transformation of the play to the stage. These three levels can be elaborated as follows:

1. The effect of the institutional choices made before rehearsal...

What effect did the 'institution', in this instance the Belvoir theatre, have on creative decisions made in particular, prior to the rehearsal?<sup>17</sup> In the majoritarian theatre practice of state theatre companies the production is primarily constructed by a prior reading of the text by the director and designer, due to 'economic' demands and time constraints.<sup>18</sup> In the work of Rex Cramphorn and other alternative artists and ensembles however, the production is constructed principally within rehearsal with the whole ensemble of artists participating. What creative choices would Armfield make or be forced to make prior to the beginning of rehearsal, in particular in regards to set and costume design?

---

<sup>17</sup> Patrice Pavis in developing an analytical model of performance includes the question: 'Within what theatre institution does the staging takes place?' In analysing the production of the *Seagull* by the director Antoine Vitez he briefly describes the Theatre National de Chaillot in Paris from the point of view of its 'spirit' of management, how it is subsidised and the audience it appeals to (in Helbo, Pavis, Ubersfeld et al 1991: 205). Jim Hiley in documenting the rehearsal of *Galileo* by the National Theatre in London gives an overwhelming sense of how the expectations and the timetabling demands of a large insitutionalised theatre structure impinge upon both the rehearsal process and the resultant performance (1981).

<sup>18</sup> The actor Russell Kiefel has commented that in the 1994 STC production of *King Lear* it was:

really disturbing that you go to your first rehearsal ... and you wait till you're given your interpretation ... everything's economic — you've got five weeks to rehearse, therefore all the creative decisions have to be made before you the actor arrive. Therefore you have to fit into these decisions. (in Fewster 1994: 15)

Simon Callow comments that similarly in England: 'the design decisions are made long before any actor is hired, the music commissioned, and most elements of the production finalised before the first reading' (1984: 110). The Canadian cultural theorist Mark Fortier in turn argues that that theatre with its adoption of corporate-style governance is 'rife with potential' for such alienation of its workers (1998: 8).

## 2. The structuring of the rehearsal schedule...

As the play's director he would be responsible for deciding how the rehearsal schedule would be structured. Robert Benedetti has described a 'traditional rhythm' of rehearsal as consisting of:

broad outlines for a time, with read-throughs and even walk throughs; then to switch to moment-by-moment detailed work for a few weeks; finally to put it all back together with run-throughs as the dress rehearsals approach. (1985: 128)

Would Armfield's rehearsal pattern reflect this traditional approach? Or would he divide up the rehearsal time in an alternative way? To what degree would he foreground the traditional approaches of discussion and analysis of the play's political background, plot and character development with the physical blocking of the actors and the 'aural' blocking of the text?<sup>19</sup>

## 3. The 'atmosphere' of the rehearsal room...

3. As the dominant figure in guiding the production to performance Armfield would also be responsible for establishing the atmosphere of the rehearsal room, the 'climate in which the play [would] grow', the 'creative state' which would reflect his, the director's own 'creative state' of mind (Benedetti 1985: 110). How much 'laughter' would he allow for example? How much 'room' for the actors would he allow to solve 'their own creative problems'? How 'collaborative' would he be?<sup>20</sup> How much would Armfield dictate and prescribe to the actors his understanding of the play and what action they should enact? The regularity with which Armfield watched and intervened in the rehearsal process would determine the rehearsal atmosphere — an atmosphere that could be variously autocratic, democratic or somewhere in between.<sup>21</sup> Finally how would this atmosphere reflect what

---

<sup>19</sup> Susan Letzler-Cole defines 'aural blocking, [as] a shaping of the aural trajectory of speech on stage' by the director (1992: 22).

<sup>20</sup> Benedetti sent 30 directors a questionnaire on directing methods, many of whom cited 'laughter' as a good sign in rehearsal though some like Grotowski would not allow it. Many also cited the importance of rehearsal as a 'collaborative' process (1985: 110).

<sup>21</sup> The playwright Timothy Daly has defined directing as deciding 'when to intervene' and when to watch the actors (private correspondence with author). Similarly the director Aarne Neeme states that: 'When to interrupt or rather not to interrupt is

Stephen Aaron has described as the change from the 'opening phase' to the 'middle and latter phases' of rehearsal? That is, from the early 'playfulness and freedom for the actor to try anything' to the later 'limitations' of setting the staging where movements and gestures are increasingly 'coordinated and mediated by the director's eye' (1993: 24-25).

The power the director has in deciding how labour and time will be used (the institution within which the theatre event is generated notwithstanding) and the rehearsal strategies he/she employs reflect the centralising of functions and the rise of the director to becoming the 'dominant creative force in today's theatre' (Bradby 1988: 1). Directors of ensembles like Rex Cramphorn have attempted to disrupt or subvert this model by giving actors greater involvement in decision making and allowing *them* to make their own creative choices in order to make them feel that the production is really theirs, thereby empowering them. Ultimately in examining how Armfield worked with the Company B ensemble I would like to explore what constitutes a director and an ensemble in action and if and how this differs in practice from casts assembled for solely one production only. Is this a genuinely alternative way of working or does it simply reflect what Benedetti defines as the process of being an 'effective director'?<sup>22</sup> In constructing an analysis of Armfield's working methodology the central question of this thesis is to attempt to determine how the company operated as an ensemble under Armfield's direction; that is, to place Armfield's practice as a director between, on the one hand, the majoritarian theatre practice of state theatre companies and on the other, the recent work of alternative directors and ensembles both in Australia and overseas.

---

probably the greatest skill you can learn as a director' (*Old Times* workshop, Centre for Performance Studies, Sydney 1995).

<sup>22</sup> Benedetti lists seven 'qualities' of the 'effective' director's 'mind' including: a grounding in 'theatrical tradition', eclecticism, being 'open ... curious and observant; ... adventurous ... risk-taking, skillful at collaboration, ... quiet authority' and patience mirrored with the ability to work 'under pressure' (1988: 7).

## 2. METHODOLOGY

### 2.1. How to Document?

The difficulties in how to 'faithfully' record both theatre performance and rehearsal processes have been increasingly debated by practitioners and theatre scholars alike in recent times. Directors Jonathon Miller and Peter Brook have remarked that 'copying meant producing something indistinguishable' (in Melzer 1995: 152) and that the filmed 'document is not only incomplete but very false' because it cannot communicate 'the full experience of what happened' (in Melzer 1997: 265). Marco De Marinis wrote fifteen years ago that video was at its best a 'faithful betrayal of performance or a respectful forgery of the original.' De Marinis argued following on from Jacques Le Goff, Michel Foucault and Paul Zumthor that 'theatrical documents ... like all documents ... [are] subjective, partial, elusive and incomplete' (1985: 388). Egil Tornqvist goes even further in defining 'partial' as not just 'limited, but as biased ... "a partial vision"' (in Melzer 1997: 262). Recording rehearsal exacerbates these problems as Gay McAuley points out rehearsal 'documentation of any sort necessarily involves selection and is therefore already in itself, a form of analysis or even interpretation' of what took place (1998: 76).

This is not to say that practitioners and scholars undervalue documentation of theatre rehearsal and documentation. If anything documentation, particularly by video, is increasing, if not lessening — 'proliferating' in the words of the New Theatre Quarterly editors and 'causing a revolution in teaching, rehearsal methods and research' (in Melzer 1995: 147). For both practitioners and academic documenters/observers video can serve as a valuable, though freely acknowledged partial, record of what happened — one out of many possible versions of the same theatre event.<sup>23</sup> While practitioners may take artistic control in producing film/videos of their own work with the resources of a commercial production available to them, the

---

<sup>23</sup> Peter Brook in 1977 said that 'the filmed document whatever the losses involved ... can be very useful for our work' (in Melzer 1995: 148) while Gay McAuley notes that in documenting theatre rehearsal 'we all appreciate today that there can be many versions of what happened' (1998: 78).

academic documenter of rehearsal often works with a varying level of recording technology. The latter's search for how to construct meaning 'objectively' is initially mediated by the recording technology employed/available, which in turn depends heavily on where the documentation takes place and the physical limitations of the documenters, themselves.

In her work in documenting professional theatre rehearsal at the Centre for Performance Studies at the University of Sydney, Gay McAuley prefers the 'presence of the academic observer' supplemented by video and/or sound recordings. She notes that while it is 'difficult' to gain entry to professional theatre rehearsal, the Centre has been successful in observing professionals work by sponsoring 'workshop productions' (1998: 75-76). These workshops are short, often a week in duration and allow professionals to work outside the pressures of a commercial production. The advantage to students and academics within Performance Studies is that they can thus study theatre artists at work in the Centre's studio, in a laboratory-type situation where recording conditions can be controlled to some degree; the rehearsal room is set up with multiple video cameras for that purpose and supplemented with observers.

This approach raises a question as to the degree to which the actual recording process then impinges (or mediates) on the rehearsal process itself. From my own documentation of rehearsal practices within Performance Studies this would seem to vary as cameras, like observers, can slide from being 'fixtures' in the rehearsal room as the actors and directors become acclimatised to their presence to actually altering the rehearsal process itself, if only briefly.<sup>24</sup> For example, on a project that I documented, an actor asked me whether the camera was 'on' when commenting on the particular approach of the (at the time absent) director. Only after I had replied in the affirmative did he continue; what he went on to say would seem to have been measured by his awareness of being recorded.<sup>25</sup> This reflects the reality that artists never entirely forget that they are being recorded, particularly when the means of recording (such as video cameras) are relatively large and always visibly present. In

---

<sup>24</sup> Susan Letzler Cole who documented over ten rehearsal processes spoke of becoming a 'fixture', a part of the rehearsal 'landscape' as she 'continuously' and 'visibly' wrote while 'people spoke to and near her' (1992: 3).

<sup>25</sup> The project was a one week workshop of *Tartuffe* by Moliere with director Lindy Davies in 1994 (in Fewster 1994: 25).

addition the artists' awareness that they have been invited to participate in a project constructed primarily to record process rather than necessarily being performance-goal orientated, may also mediate what they say.<sup>26</sup> The actor's comment also reflects a traditional fear of being captured commenting on another, of not wanting to be seen betraying rehearsal secrets of what is 'traditionally regarded ... as private' and, at worst, losing work through bad mouthing their fellow colleagues (1998 McAuley: 75).

The actual number of observers/documenters in the rehearsal room would also seem to sometimes alter the rehearsal process itself. In another example from Performance Studies, during one workshop an actor momentarily stopped rehearsing because she found it difficult to rehearse in the presence of a class of observing students. She felt the pressure of an audience and rehearsal became for her more performative than explorative.<sup>27</sup> McAuley herself has contended that 'rehearsal analysts may be shown' what practitioners want them 'to see'; in effect a 'performance of a rehearsal rather than a genuine rehearsal' (1998: 77). These are perhaps isolated incidents from a Centre that has made enormous inroads into bridging the gap between academics and practitioners over the last ten years in Sydney. Indeed the Centre's focus on process has often served as a platform for artists to articulate those processes outside the pressures of a 'real' production, allowing Lindy Davies for instance, an opportunity to create a unique record of her work. Such incidents do, however, raise issues of how place, and method, in this instance the institutional framework within which the workshops take place mitigates to some degree the recording of rehearsal process.

Alternatively one might ask whether the documenter alone in the field, a visitor to an industry rehearsal space rather than the inverse, might be better placed to record a rehearsal process? One is after all encountering the theatre artist on their home ground. However even if the documenter is able to gain access to the preparation of professional productions there is an immediate

---

<sup>26</sup> Lindy Davies for example, on the first day of the one week's workshop of Moliere's *Tartuffe* said that the reason she was there was to 'show' her 'process' (in Fewster 1994: 16). She subsequently seemed to demonstrate her process for not only the actors, but for the audience of observers and the recording equipment as well. In her own words 'If anyone wants to learn about my process, I tell them they should go and see Gay McAuley at Performance Studies' (private conversation with author).

<sup>27</sup> The project was a 'Gender and Performance' workshop that focussed on an excerpt from *Deathwatch* by Jean Genet with director Adam Cook in 1994.

reduction of the technological tools available for recording rehearsal processes in the wild, so to speak. Video cameras would seem not only overly intrusive, but require more than one operator/documenter in the field. The lone documenter armed even with a simple tape recorder strikes similar potentially intrusive and logistical problems. McAuley has commented on the 'practical' and 'strategic implications' for would-be documenters; in her experience, one can't both observe and record sound (or video record) as 'observation is a full-time role that precludes taking responsibility for sound recording or camera operation' (1998: 81). Ruth Finnegan, concurs stating that 'machine management can distract from observing human interaction' citing Bruce Jackson's law of inverse attention (1992: 63). Finnegan suggests, however, that:

Writing has been the dominant technology of recording oral forms in the past and remains convenient particularly for commentary on general situation, descriptions of action and has fewer constraints on mobility and sometimes ... [creates less] attention than more mechanical means. (1992: 68)

Therefore perhaps the documenter, while outside the recording resources of laboratory in the field but armed with pen and paper has an advantage in being able to impact less on the rehearsal process in the actual recording. Susan Letzler Cole in documenting rehearsal preferred to use 'a notebook rather than a tape recorder' because she felt it was part of the 'techniques of being present' that she had learned from previous rehearsal process observation — techniques that were less likely to 'disrupt or betray the special conditions of rehearsal work'; that is, repress 'risk-taking, spontaneity, intimacy', although she added that 'some interviews were initiated without so much as a notebook, in corridors or doorways' (1992: 3). In fact regular observers of rehearsal at Performance Studies have commented that often important things are said by the actors over coffee breaks.<sup>28</sup> The relaxation of a break away from work and/or away from recording seems to provide a brief loosening of any inhibitions or concerns on the part of the artists. This is an example of where, whether in the field or in the laboratory, the individual documenter can sometimes go where the camera can't. However, in my own experience what is then said to, or in the presence of the documenter, will depend very much on what sort

---

<sup>28</sup> On at least two productions that she observed McAuley regretted not having a camera outside the rehearsal room, in a 'marginal space' where 'key performance decisions emerge[d]' (1998: 79).

of relationship and what sense of trust they have built up with the practitioners. Letzler Cole herself noted that company members 'during breaks in rehearsal ... spoke to her fairly unselfconsciously and spontaneously' after they had become acclimatised to her presence (1992: 3).

Like Letzler Cole I decided to simply take notes. I felt more comfortable sitting watching and writing without having to attend to recording technology. Letzler Cole adds that in this 'technological age' and hidden amidst a team of artists and technicians she was 'less invasive' than she 'originally feared' (1992: 3). However even with just a pen and notebook the observer is still in full view of the artists rehearsing. McAuley cites examples of performers' curiosity about what students write (1998: 80). As I documented the rehearsal of the *Blind Giant* with this more primal technology there was still the occasional fear expressed by an actor that what was being recorded could be held against them. For example, one actor, immediately after he had commented negatively on another in the company to Armfield, said to me that if other people became aware of what he had said through my record I would 'bring Australian theatre to its knees.' Ironically, because writing is invariably not continuous, like video or sound, the sudden act of writing in response to a particular moment in rehearsal highlights the act of documentation.

Letzler Cole also noted that she was told by the artists that she 'appeared to be writing down everything' (1992: 3). In my documentation of Company B the same thing was said to me. In fact I was taken by surprise when I suddenly had to validate my choice of recording tools to the company itself, when the director Neil Armfield on observing how much I was writing down asked: 'Why don't you use a tape recorder?' There were three reasons for this: first I didn't want a huge and potentially overwhelming collection of tapes. I calculated that with 90 minute tapes I would need at least 4 a day which made 20 a week and 100 for the whole 5 week rehearsal period. As it was I filled 4 foolscap notebooks in note taking alone. Second I didn't want to intrude on the rehearsal process itself with a tape recorder always present with tapes being changed every forty-five minutes. And third, as McAuley and Finnegan have pointed out, what one can observe is limited when having to constantly attend to recording technology.

McAuley, however, has argued that video or sound recordings of rehearsal can provide a 'valuable corrective to interpretive views that may develop' after the recording when a formal

analysis of the data is undertaken (1998: 76). This is a fair point because in reviewing my notes it was clear that even when I had to 'my mind' clearly signposted the path of a particular discussion something was invariably missed out. That rehearsal is predominantly an oral form, 'a highly verbal activity', has immediate implications for the documenter (1998: 76). Finnegan has qualified the traditional recording device of pen and paper as having limits for 'documenting and capturing textual content' suggesting that to:

preserve, disseminate and analyse oral forms which are by definition ephemeral it is near essential to employ ... [mechanical] means to make them more lasting. (1992: 62 & 68)

The only corrective that I had was to ensure that I regularly reviewed my notes and clarified any questions that arose with the actors in question — a similar process to that employed by Letzler Cole. As I did not want to interfere with the rehearsal work these questions were usually asked over tea breaks; most actors were happy to talk to me and indeed clarify what they had said or done earlier corresponding to Letzler Cole's observations of similar responses by actors (1992: 3). In fact perhaps drawing on my own technique of 'being present' without 'disrupting' rehearsal, learnt at Performance Studies, once I had established sincere empathy and interest in understanding the process(es) at work in the company, some actors were very keen to articulate their idea of what is going on — a form of empowering of the single actor's voice, away from the director and group, who could then speak without hesitation on behalf of the whole; a chance to reflect on the process when momentarily away from it rather than being in it.

## 2.2. What to Document?

Both De Marinis and Patrice Pavis have separated the 'what' to record from the 'how' to record (De Marinis 1985: 384). Melzer has added that to 'notate' is to 'interpret' and therefore the why — or the 'intention' in Pavis' words — underlying the notation becomes critical (1991:150). If the choice of recording technology and its limits implies a degree of interpretation of the rehearsal process a second layer of interpretation arises when the documenter decides on what to actually document (and by inference why). Within this 'what' there are decisions to be made on both macroscopic and microscopic levels — within 'cultural' and 'situational' contexts — that will determine the content of the rehearsal record (Halliday & Hasan 1985: 6-7). The analyst must construct an overview of where to situate the rehearsal process with what came before and came after and then to decide which individual elements to highlight within the actual rehearsal process itself.

Traditional documentation of theatre has tended to concentrate on the performance itself (Melzer 1995: 150). If the rehearsal period, itself, has been documented, the intention of the analyst has been to use their records to trace the 'genesis of performance decisions' - the focus has been on 'product' rather than 'process' (McAuley 1998: 78). Perhaps this reflects the general drive of the artists themselves towards their performance goals. De Marinis has talked about the need to document the

process not only the product ... [but] what went before and towards the theatre product ... [including] the planning, preparation, rehearsal, the whole life of the theatre in order to know the culture that the theatre exists and is experienced within. (1985: 384)

He cites as an example Eugenio Barba's ethnographic-style films that focus on the whole 'rubric of group culture.' De Marinis argues this is a consequence of shifting attention from product to process, from 'performance to whole environment' (1985: 384). McAuley has echoed this, describing a 'postmodern ... shift in interest from the reified art object to dynamic processes of production and reception.' McAuley has also identified the difficulties of defining the boundaries of rehearsal study, particularly as important design decisions, for example, have

often already been made before rehearsal proper begins (1998: 79). A study of rehearsal only, risks privileging this part of the theatre process at the expense of the 'whole environment.' Rehearsal therefore, while seemingly isolated for independent study, needs to be viewed as intricately connected to and continuous with what went before — decisions made prior to rehearsal — and with what came after, the actual performance. The impossibility of ignoring performance as an integral part of the overall structure of generating a theatre event is reflected by practitioners themselves. Peter Brook for example, when he first set up his international centre in Paris attempted to concentrate solely on process, on 'research' but found the inalienable need to perform, to 'test' the results of the group's work in front of an audience (1988: 105).

The search within rehearsal itself for an understanding of the culture of the theatre company at work asks of the documenter who and what they will foreground and why. Will this be the 'exchanges between *all* [italics mine] those who participate in the creation of the performance' as proposed by De Marinis (in Melzer 1997: 263)? Or in Denis Bablet's words: 'the work of the director with the actors and the influence of *one* upon the *other* [italics mine]' (in Melzer 1995: 153)? Or perhaps a focus on anecdotes? In her study of rehearsal practices in the Sydney Theatre Company Marion Potts has positioned the anecdote as a major component of rehearsal practice (in McAuley 1998: 76). If rehearsal is contained primarily within an oral paradigm as highlighted by Potts and McAuley the documenter must determine both which aspect(s) of the rehearsal discourse they will focus on and *who* out of the artists being observed will be highlighted at the expense of others involved in the rehearsal process.

Complicating the documentation of rehearsal, is that while acknowledging the primary 'verbal activity' of rehearsal one is also mindful that as rehearsals become less interrupted by questioning, discussion, explanation and suggestion between director and actor, rehearsal takes on an increasing visual significance; that is, as the work is being assembled for the performance season one is increasingly watching and listening to runs of scenes, acts and the whole play itself rather than listening to the primary oral discourse of early rehearsal. Certainly I recorded considerably more dialogue amongst the company in the first week of discussion than in the last week of rehearsal when the play was in technical rehearsal in the theatre. Consequently the documenter may need to also give increasing visual attention to the use of space as performance signifier as

the blocking is developed (McAuley 1998: 77). Or in Patrice Pavis' words the observer must develop a 'synchronic reading of theatrical signs' including the 'composition of the stage space and the utilisation of the space by the actor' (in Helbo, Pavis, Ubersfeld et al. 1991: 136).

Within the rehearsal room a tape recorder can potentially record most of this oral practice, exempting verbal activity in liminal spaces as outlined previously. Video technology can add to this a visual record with a particular point of view of the development of potential visual signifiers in the production, depending on how many cameras are used and where they are placed. Writing, however imposes physical limitations. This has important implications for defining the subject(s) of subsequent analysis. Although I did try to write down 'everything' it simply wasn't possible. The brain filters and edits conversation as it is heard and written down. I developed a form of shorthand that concentrated on who was talking, who they were talking to and what action they wanted the rehearsal process to take. As McAuley has pointed out, a selective 'description', an 'analysis' of what was being said was already taking place (1998: 76). As I became increasingly aware of the limitations of pen and paper some selective decisions were by necessity taken on the spot. For example, I decided not to record the numerous script changes that took place but to concentrate on the dialogue and exchanges between the company members that led to these changes — a choice had to be made between one or the other and my decision was to emphasise process.

Of course the question that then arises is just whose process is it that is being observed. I found myself particularly concentrating on recording what the director said — a response to how I perceived Neil Armfield was leading and guiding the group. It is therefore fair to say that the documentation was recorded with a view to analysing the director's process in the ensemble — an approach that reflects the foregrounding of the work of the director by current and previous documenters and which in turn echoes the twentieth century view of the director as the dominant theatre artist (McAuley 1998: 75 & Brady & Williams 1988: 1). Such historical practice does not necessarily validate the documenter's decision which is admittedly 'loaded' in privileging the director over the others (McAuley 1998: 81). One could for example, alternatively focus the documentation on a particular actor or actors or even the designer. It also determines to a large degree the subsequent master narrative of the analysis, as will be seen; even when I quote actors it is invariably in

relation to how they work within the director's process. I took the view in this instance that the director was the person responsible for the production as a whole and the dominant authority in the rehearsal room through whom all the company members work. Armfield was the primary locus of rehearsal activity; his process was therefore a convenient centralised point of study. I acknowledge that this is yet another partial rendering of the whole rehearsal process as there are potentially many differing stories that can be told, depending on which artist's process and viewpoint is foregrounded.

The decision to concentrate on the director's process, reveals, in Pavis' words, the 'intention' of the documenter. Behind this intention lies the 'interest, preoccupations and prejudices of the documenter themselves' (Melzer 1997: 264). According to Gadamer 'prejudices of the individual far more than his judgements constitute the historical reality of his being' (in Fischer-Lichte 1991: 207). For instance my interest, preoccupation, prejudice and being is admittedly reflective of my own work as theatre director. Fischer-Lichte writes that the 'location of the interpreter both in history and in his or her biography determines the process of interpretation' (1991: 207). Thus for this author this 'process of interpretation' is also partially governed by my intention to study other directorial practices in order to learn from them. A director studying another director is perhaps an example of a confrontation with what is 'essential' in one's self by discovering what are the 'native's main passions' (in Okely & Calloway 1992: 119). Speaking personally, the 'passions' in creating theatre are varied but include in general terms the excitement of creation in rehearsal and the success of the play in performance. I could not help but identify with such aspects of the whole theatre event. In ethnography this empathetic involvement in fieldwork is countered with a critical detachment in the writing up of the field notes — a dialectic between the 'construed "raw" experience' of immersion in the field with a later distanced textualisation (Tyler 1987: 101). This classic twentieth century anthropological method of 'participant observation' attempts to locate both the documenter and the subjects of study within a mutual encounter in the field. More recently this method has sought to specifically position the observer and the observed — the self and the other — in the narrative of the written up ethnographic text. Situating the observer in the process of interpretation of theatre performance and rehearsal has increasingly been viewed by theatre academics within such an ethnographic frame.

### 2.3. Ethnographic Approaches

Participant observation has been broadly defined by James Clifford as 'a peculiar amalgam of intense personal experience and scientific analysis.' More specifically Clifford suggests that it is

A shorthand for a continuous tacking between the inside and the outside of events on the one hand grasping the sense of specific occurrences and gestures empathetically on the other stepping back to situate these meanings in wider contexts. (1988: 34)

For McAuley the documentation and analysis of rehearsal at Performance Studies has first 'unconsciously' and then consciously followed this method. She describes academic observers in the rehearsal room as being 'in it, but not of it,' and as later 'writ[ing] up' the results of the fieldwork in a fashion analogous to the ethnographer (1998: 77). Helene Bouvier, in introducing a volume of the *Theatre Research International* devoted to anthropology and theatre, cites this anthropological method — empathetic field 'immersion' followed by a later 'purposeful distancing' in critical writing — as the most important for theatre studies. She notes that 'observation and reflection' on theatre processes has 'much in common' with the 'deciphering of behaviour, codes, references and roles' inherent in 'ethnological work' (1994: 1). Tom Burvill observing the Armfield directed Company B production of the *Seagull* by Chekhov, described his 'methodology' as being a 'reflexive ethnography of production — the mix of "mutual knowledge" obtained through the interview/observation process and "critical distance"' (1997). Given this increasing interest of theatre scholars in such 'aspects of the anthropological method' (Bouvier 1994: 1), the recent critical approaches of ethnographers to the fieldwork and writing up phases of their work have important implications for the documenter of theatre rehearsal.

### **(a.) In the field**

Ethnographers like Kirsten Hastrup and Barbara Tedlock have argued that 'fieldwork is situated between autobiography and anthropology' and that 'it is not the unmediated world of the others but the world between ourselves and the others' (in Okely & Calloway 1992: 117). It is from this 'betweenness', a 'liminal space', that the 'others' speak from in the ethnographic dialogue' (1992: 23). Tedlock has highlighted the work of native ethnographers in 'revealing the observer and the observed are not entirely separate packages' but rather that the 'self and other [are] experiential subjects working [together] to co-produce knowledge' (1991: 80). According to Frederick Barth this 'knowledge' is a

major modality of the culture being studied — knowledge referring to what people employ to interpret and act on the world: feelings as well as thoughts. (1996: 66)

The implication to a documenter of a theatre rehearsal is to attempt to 'co-produce knowledge' with the subjects being studied, in this instance with Neil Armfield and Company B in order to determine how they function in producing theatre.

In constructing such a knowledge of what a Belvoir Theatre culture meant, the subjects themselves need to be identified and given credit for their active collaboration with the documenter: Neil Armfield's permission and the actors' acceptance of my observation and note-taking within the rehearsal. Victor Turner has stated that:

To each level of sociality corresponds its own knowledge and if one wishes to grasp a group's deepest knowledge one must commune with its members, speak its essential we-talk. (in Jules Rosette 1975: 8)

As documenter I need to acknowledge the following company members with whom I was able to 'commune', whose openness allowed me to 'grasp' the 'we speak' of the company. They are the actors such as Kerry Walker, Peter Carroll and Russell Kiefel who in private conversation with me, clarified through their interpretation, the company's working method; the Stage Manager, Karen 'Kazz' Rodgers, who generously offered her thoughts on Armfield's working method and finally the Designer Stephen

Curtis who must be thanked for his insight into the design rationale. The moments in rehearsal when I was actively able to commune with the company were outside of the formal rehearsal process, usually over tea breaks (as noted earlier) when I asked questions that were vital to my understanding of the company's processes. Like the ethnographer, in these instances there is a degree of 'symbolic violence' in this approach in that I didn't 'respect the other's right to remain silent' in this 'cultural encounter' (in Okely & Calloway 1992: 23). While on the one hand by asking questions the 'informants' responses represent an [invaluable] externalisation of inner cultural experience' otherwise unavailable to the documenter, on the other hand these 'questions are unsolicited and 'will of necessity shape the answers' (1992: 121-122). Thus the documenter must attempt to discern whether the informant is speaking 'cultural truths' or simply providing 'circumstantial responses' (Clifford 1986: 107).

McAuley has noted that anthropology is traditionally a study of cultures 'far removed from that of the anthropologist' and that this is being translated by theatre academics to the study of our own culture: 'The "other" within our midst' (1998: 77). As pointed out earlier, Armfield spoke of a 'Belvoir culture' in opposition to a Sydney Theatre Company culture; both companies can be positioned or situated as cultural or sub cultural groups within the cultural field of theatre production in Australia. Similarly there are distinctions to be made between the specific theatre making culture of the author and that of Company B. Drawing on the work of Harding and Rose, Tedlock requires that the 'culture ... of the inquirer be placed within the same historical moment, or critical plane, as the subject of inquiry' (1991:80). The author comes as a director with a cultural history of theatre making with young people, with his own professional though intermittent ensemble<sup>29</sup> and with experience within the state theatre company system to study an alternative high profile director and ensemble engaged in their own theatre making. In a 'heteroglossic' encounter between the ethnographer and the other, 'languages' and 'cultures' are assumed to 'not *exclude* each other but to intersect with each other in many different ways' reflecting a 'global condition' of people interpreting 'others and themselves' (Clifford 1988: 22-23). Potentially enhancing such a 'heteroglossic' intersection with the Belvoir Company is the author's own prior

---

<sup>29</sup> The author's part-time theatre company, Shifting Point, was founded in 1990 and has produced French classics such as *No Way Out* by Jean Paul Sartre, *Eden Cinema* by Marguerite Duras and new Australian writing including *The Australian President* by David Ross and *The Private Visions of Gottfried Kellner* by Timothy Daly.

intersection with the Belvoir Company is the author's own prior theatre experience; that is, the author like, 'all ethnographers', is a 'positioned subject' and able to 'grasp certain phenomena better than others.' Kirsten Hastrup describes this ability as 'defined by age, gender ... status [and] lived experience and which enables or inhibits particular kinds of insight' (in Okely & Calloway 1992: 119). In Pierre Bourdieu's words this translates as 'a feel for the game ... a set of dispositions which generate practices and perceptions' (1993: 5). According to Hastrup this ability to communicate with the culture being studied and its purveyors has the potential to 'transform the ethnographer from observer to seer, and his/her knowledge from observation to insight [representing] more than an iconic expression of visibility' (1992: 119). If the 'reflexivity, specificity and individuality of the observer are ever present this must therefore be acknowledged explored and put to creative use' (1992: 32). In practical terms, for me, this means recognising any advantage in being able to identify, compare and contrast the observed theatre rehearsal processes with those processes personally previously experienced or encountered in my own work and/or training. For example, my own directorial ambitions drew comments from one of the senior members of the company, Kerry Walker. This contributed to me reflecting on both my own and Neil Armfield's directing processes.<sup>30</sup>

According to the other observer in the rehearsal room, Gerry McLaughlin (normally a mechanist with the company), Armfield would expect me to find my own 'position' within the rehearsal room. If as 'the ethnographer' the rehearsal analyst

is reinvented by her position in the field-world, and by her relations to the informants, the experience is [likewise] one of self-dissolution and it is inherently anxiety provoking. (in Okely & Calloway 1992: 120)

It certainly was a challenge for this author to simply watch and record and not to intervene directly in the rehearsal process as his own directorial dispositions, practices and perceptions would often urge. My position would be for most of the time that of quietly listening, writing and watching the rehearsal in action. I documented every day for the length of the rehearsal period (five weeks) and intermittently over the season. After I couldn't make

---

<sup>30</sup> For example, Kerry Walker said to me during rehearsal that a director should 'always give a firm answer to a question from a actor, even if you don't know the answer' in order to give a sense of confidence to the actor.

a technical rehearsal one morning the assistant director Steve Evans commented: 'we missed you.' It was the observer observed and perhaps a form of acceptance. If I was aware of the need to 'capture' every day of rehearsal, of not privileging any day over the other in order to contribute to an equitable record, I also became aware of the importance, from the actor's point of view, of being there consistently. One of the actors, Ralph Cotterill who interestingly had been in the original Peter Brook production of *A Midsummer Night's Dream* commented that the documenter on that production (David Selbourne) was 'this guy' who had seemed to attend rehearsal 'whenever he liked.' This comment would seem to reflect that an actor's sense of faith, trust and respect in a documenter — how they position the documenter — is measured to some degree by the documenter's consistency in presence. In another example, when Tirzah Lowen missed a day of rehearsal of the RSC production of *Anthony and Cleopatra* which he was documenting the actors demanded to know where he had been as he had 'missed something really good yesterday' and that he'd now 'notice the difference' (Lowen 1990: 107). If directors sometimes model themselves in rehearsal as an audience representative, observers 'it would seem' can't but help be placed by the actors in that audience as well. Directors talk about the 'quality' of attentiveness that they attempt to give to actors in their watching. A documenter, it seems to me, can learn from this and attempt to watch the whole rehearsal room, director and actor with the same attentiveness. It is perhaps this 'quality' that actors learn to know and trust.<sup>31</sup>

If I was expected to find my own position in the rehearsal room I was certainly helped. My position did occasionally blur from 'distanced' observer to genuine participant when I momentarily suspended commentary and concentrated on writing down dropped lines for the duration of a run of the play at Armfield's request. Armfield also occasionally asked Gerry McLaughlin, the stage management crew and me whether we liked or disliked the blocking in a scene. This was to my mind not because of the 'potential disruption' of the observers in the rehearsal room but was Armfield's way of involving everyone

---

<sup>31</sup> Ariane Mnouchkine talks about a 'quality' that she encourages her actors to give in 'watching' each other that helps them to 'understand' what the other is doing. She adds that this is 'perhaps' what she does 'well': watching and listening and thereby giving the actors the 'courage' to continue (in Kiernander 1993: 14 & 20). Peter Brook, in turn talks about how an 'audience affects actors by the quality of its attention' (1968: 27). Directors are also aware of the power of the 'look' in the Sartrean sense from anyone in the rehearsal room. Lindy Davies commented in a one day workshop at Performance Studies in 1995 that she could for example pick-up on a negative vibe, even if mute and by inference this had the power to disrupt her work.

Tedlock in pushing for a narrative ethnography argues that a 'situated narrator ... enables the reader to identify the consciousness which has selected the experiences within the text' (1991: 78-79). I could therefore 'situate' myself as an empathetic and interested observer who (infrequently) directly assisted the production: a collaborator in not just recording information for this thesis but also occasionally for the company as well.

## (b.) Writing up

If the observer/documenter both positions themselves and is positioned by their subjects into playing various 'roles' in the field, the writing up of the ethnographic and narrative text, the creation of the rehearsal story is a 'theatrical act' in itself (in Melzer 1991: 266). Ethnography is considered to be 'enmeshed in writing' and is 'minimally a translation of experience into textual form' (Clifford 1988: 25). This textualisation has been seen as the 'process through which unwritten behaviour, speech, beliefs, oral tradition and ritual become a potential meaningful ensemble' (1988: 38). What has been questioned as problematic with this second part of participant observation by James Clifford and others is the unquestioned claim of the documenter to appear as

the purveyor of truth in the text: the experiential "I was there" of the ethnographer as insider and participant ... [which serves as a] unifying source of [textual] authority. (1988: 35)

Paul Rabinow has commented that once this 'unique authority' has been established the writer often 'disappears from the text' thereby establishing the anthropologist's hidden 'scientific authority' (in Clifford 1986: 244). Judith Okely has argued that a way to disrupt this monograph is for the 'reflexive I of the ethnographer' to subvert the idea of the observer as 'impersonal machine.' This 'autobiographical insertion' is conceived as being different from the 'stamp of author's authority: not simply "I was there", but the self and cultural category whom the others confronted, received and confided in' (Okely & Calloway 1992: 24). The implication for the rehearsal analyst is to attempt to show in the text, how others related to the self in the field.

This experiential 'I was there' authority of the ethnographer is identified by Clifford as one of 'four modes of [textual] authority — experiential, interpretive, dialogical and polyphonic.' All these modes of authority are in, Clifford's words, 'available to the writer', though 'none are pure or absolute' but offer differing approaches that one needs to be aware of, as they often converge in the same text (1988: 53-54). Clifford's main concern with purely interpretive writing is that it excludes potential dialogue between the self and other which offers another way to break up the otherwise monological text (1986: 245). Additionally while

the mutual encounter between self and other in the field has always a heteroglossic or 'polyphonic' quality, that is, multivocal, this quality of the field encounter risks being consumed or lost in the written up text which is constructed by the self alone — there is an ever present danger of informants' voices not being able to 'penetrate the discursive speech of the ethnographer' (in Okely & Calloway 1992: 121). Postmodern ethnography dreams of a polyphonic text, a 'utopia of plural authorship' where informants speak with equal authority as the analyst and where the readers are freer to make up their own minds. Clifford however regards this form of authority as remaining 'utopian' because such a text, which would in effect be a collection of lengthy quotes, would still require an editor. The reality is that in dialogic and polyphonic texts quotations will still always be 'staged by the quoter' (1988: 50-51). According to Clifford 'writing a culture' is therefore not an 'empirical entity but an analytical implication' (in Okely & Calloway 1992: 122). While I may pretend to be writing up Neil Armfield's process it is bounded by my own process of writing. In McAuley's words, it is 'still my analytical enterprise and I am inserting the actors' and director's stories into another larger narrative' (1998: 82). While Kerry Walker can lay claim to the author as 'our Boswell'<sup>32</sup> the author in turn can lay claim to Company B as 'my people', not in the 'sense of individuals' but as 'inhabitants of the world my writing creates' (Hastrup in Okely & Calloway 1992: 126). Current ethnographic practice asks that authorial authority 'work through the specificity of ... self in order to contextualise and transcend it' (1992: 2). If for the practitioner Peter Brook this is a matter of showing there is 'nothing up the sleeves', for the theatre ethnographer it is more a case of emptying one's sleeves and disclosing one's prejudices in both the observing and writing up phases (1968: 109). In another practitioner, Jonathon Miller's words, 'it is better to be conscious of your preconceptions rather than simply being a victim of them' (in Melzer 1991: 263).

---

<sup>32</sup> Walker described the author thus — in the sense of the ensemble's own personal scribe — when speaking to a member of Performance Studies staff.

## **2.4. Schema — What and How to Analyse?**

Segmentation of the theatrical text is a fundamental operation in any analysis. If the text cannot be divided into units which have a lower degree of semantic coherence than does the text as a whole, then it is not possible to conduct an analysis in the first place, whereby analysis is understood as the very process of attributing meaning to individual elements and substructures and an overall meaning to the text. (Fischer-Lichte 1983: 224)

Erica Fischer-Lichte, in setting up a semiotic analysis of performance, argues in a way that the textual forest can only be seen by first looking at the individual trees. This has something of a structuralist viewpoint in attempting to realize 'the aim of uncovering the underlying mechanisms/logic/codes rules: the "real" structure beneath and behind the contingent surface phenomena' (Finnegan 1992: 37). However, Fischer-Lichte is quick to point out that such a process of 'understanding' is never 'complete' as, like a hermeneutic circle, the meanings of individual elements only make sense when viewed as a whole while the meaning of this whole only makes sense when the meaning of the individual elements are individually constituted (1983: 213-214). The hierarchy of meaning, the importance assigned to each of these elements and subsequently to the meaning of the whole by the analyst, is, necessarily, subjective, further clouding the impossible 'goal' of arriving at an 'objectively given "correct" meaning' (1983: 217). Constructing this hierarchy through initially deciding what to interpret like the 'interpretation' itself, as pointed out by Fischer-Lichte, is 'thus ... [a] steered creation' (1983: 216). If one substitutes rehearsal process for performance text the analytical problems are not dissimilar.

In attempting, in the previous chapter, to outline the aims of this thesis, by setting up questions through which to examine the rehearsal process, a segmentation of sorts was already begun. The difficulties of deciding on how to fence off the field of the study, the boundaries of the event were also noted. The American theatre director Anne Bogart has talked about the 'acts of violence' (1997) that she feels she perpetrates in giving directions to an actor of where to move and how to say a line at

any given moment; that is, in giving a 'fixed point'<sup>33</sup> or points to an actor's performance in rehearsal (Lecoq 1987: 100). It is somewhat analogous for a documenter of a rehearsal process to decide which parts of a rehearsal process they will highlight for analysis; through similar 'acts of violence' which elements of the rehearsal process will be highlighted at the expense of others. That such acts are necessary is guaranteed by the copious amount of note taking that the documenter accrued. In an ethnographic sense this mirrors the 'symbolic violence' in interviewing informants and which is now matched by a textual violence in revealing an analytical hierarchy. In a literary sense this reflects that any 'narrative condenses most events greatly' and what is given is 'not the events-in-themselves, but a *discourse* about the events.' Therefore how the discourse 'modifies' or 'mediates the events' needs to be discussed (Bonnycastle 1996: 156). The underlying motivation, or Pavis' 'intention', for this compulsorily required selection then becomes critical in determining the field of study, while from the hermeneutic circle there are the two seemingly opposed factors that need to be reconciled; that of wanting to cover detail while at the same time also giving a broader, overall picture of the processes at work.

A rehearsal analysis potentially offers both the opportunity to analyse rehearsal as performance orientated and rehearsal as process. The diachronic aspect of the whole theatre event, the drive forward of the theatre artists can be useful in relating to the reader how the pressures of time impinge upon both process and product. How performance pressures mediate the rehearsal process and vice versa is close to the principal question of the thesis and offers a useful thematic tool to examine and compare Armfield's process with other directors from the existing literature. The natural narrative flow and often dramatic story of preparing a play for performance also offers a compelling narrative for the writer to follow. However while following this general narrative drive one is mindful to give attention to describing and interpreting not only the getting to performance but how the company got there; that is, to be aware of how rehearsal 'explorations' that didn't make it to the performance, 'red herrings' in McAuley's words still are an important part of the rehearsal process (1998: 81). Viewed in

---

<sup>33</sup> Jacques Lecoq describes such a fixed point or *le point fixe* as that which gives perspective to movement. 'In what moves, we only see what is still' (1987: 100-101). The movement teacher Monica Pagneux in conversation with the author situated *le point fixe* in a broader sense as sometimes a mental obstruction. The idea of *le point fixe* is therefore infinitely flexible applying both to physical and aural blocking as well as to personal psychology.

another way this means to be aware of how through the 'process of experimentation' in rehearsal the 'ghosts of previous decisions throw the choices made into stronger relief' (Lowen 1990: 64).

An attempt to foreground what Armfield the director has foregrounded in rehearsal arguably requires highlighting his division of time, his questions, his directions to the actors and their responses and questions to him; in Brook's words, the 'in and out movement' of dialogue between director and actors (1988: 7). I have chosen structures within both Armfield's process and the play itself that offer in my view both narrative and comparative opportunities. These include:

First taking into account notes from the first day of reading and the design presentation on the second day of rehearsal. These give a general overview to the director and the designer's conceptual approach to the play and in turn how the actors responded to this approach: the beginning of a sense of how the ensemble operated as a whole. This also relates strongly to the first question within the aims of the thesis: how pre-rehearsal decisions affected the actual rehearsal.

Second I have decided to focus on individual scenes and how they were discussed, blocked, and run into performance to give a sense of how the company worked in detail. However, there is also a need to be wary of losing holistic focus. Therefore to analyse how the company functioned, a variety of scenes need to be studied enabling a comparison between scene work facilitating the search for linkages; that is, recurring patterns of activity. This means attempting to situate strategically located fields of study or loci that can best provide thematic material for discussion and subsequent analysis. In deciding which scenes to foreground for discussion there are in turn two primary criteria that I have utilised: on the one hand selecting scenes with different levels of group participation; that is, the number of actors involved, and this divides into three categories:

- (a.) 'Company' scenes (Involving all the actors)<sup>34</sup>
- (b.) Smaller ensemble scenes
- (c.) Two handers

and on the other hand taking scenes from different acts; that is, different points of rehearsal time pressure, in relation to the

---

<sup>34</sup> This is a term that Armfield himself used when referring to scenes that involved all of the company of actors.

approaching performance. In view of the thesis intention to explore how the group operated together, scenes involving all the company become vital in setting out the general tone of the rehearsal room. Scenes with smaller numbers of actors enable a comparative analysis with how sub-units of the company worked together; that is, to compare how the group worked as a whole with smaller groups that were largely independent of each other during the middle part of the rehearsal period. In filmic terms, these wide field shots and close-ups offer potential insight into the director's techniques including Armfield's vocal and physical representation and explanation of lines and action to the actors and his working relationship with both veteran actors and with new-comers in the group. The chosen scenes emerge as fields of study following revision of the field notes. They highlight the search for the answer to the question of what proportion of time the company was operating from group consensus and/or directorial instructions. This analytical methodology is partly essentialist and opportunistic in searching for patterns in the construction of the performance text by the director and the company; that is, group operating structures and/or the director's personal strategies. The author's specific interest is to explore to what level an ensemble company can work democratically, to define at what point the director intervenes, chooses and sets a move, an intonation, within a scene.

Third within this analytical framework attention is given not only to focussing on how the company took the text from page to stage, but is also alert to company discourse that comments on wider themes of method and culture of the group — reflective discourse that often arises out of constructing the performance text but is not necessarily bound by it. For example, when group members momentarily distanced themselves from the process at hand and comment on it such as Armfield's reference to a 'Belvoir culture' or Kerry Walker's incisive comments on how she works with Armfield.

Fourth a brief overview is given of critical response to the performance. This is to give some sense of how audiences and critics responded to the performance event and in turn an opportunity to give some perspective to the relationship between the rehearsal and the performance event and how one affects the other.

Fifth sections of the nearly completed thesis were shown to selected company members for their responses which are included in raw form in the appendix of the thesis and are also

incorporated into the conclusion — a practice reflective of contemporary ethnography:

the back and forth movement ... [that] include[s] a return to the original subjects and the incorporation of their responses in a further stage of analysis.  
(McAuley 1998: 84)

Actors were selected because they featured in the scenes chosen for analysis and included veterans Peter Carroll, Russell Kiefel and Kerry Walker and newcomers Jason Clarke, Catherine McClements and Hugo Weaving. The amount of material that was sent to the actors depended upon their time commitment so that while only chapter 7 was sent to Russell Kiefel, chapters 4 and 5 and chapters 4 and 6 were sent to Peter Carroll and Kerry Walker respectively. The contents pages of the thesis were also included to place the material sent in the context of the overall analysis. Responses were unfortunately received from only these latter three actors. Material was also sent to Neil Armfield, who declined to respond, commenting that he tended 'to stay away from theses' as they took up too much time.

Finally in incorporating the actors' feedback with the conclusions drawn from the observation and analysis of the chosen scenes an attempt was made to place this within a larger theatre culture context. Of particular interest were other practitioners' experiences of rehearsal processes. While there is a slow but steadily increasing amount of literature emerging internationally that documents theatre rehearsal process, this practice is still in its infancy, particularly in Australia. In this respect this thesis, while still hopefully a useful study of contemporary Australian theatre practice, is limited to some degree by the lack of comparative published rehearsal documentation in this country.

### **3. THE FIRST WEEK - A 'COLLECTIVE UNDERSTANDING'**

#### **3.1. The First Reading**

At 10.30 A.M on Monday the 10th July 1995 Company B gathered in a circle of chairs on the set of the company's current production of Genet's *Splendids*. All twelve of the cast had worked with Armfield previously and most had been involved in Armfield's productions of Shakespeare's *Hamlet* in 1994, and *The Tempest* in 1991 & 1995. Similarly the design team and stage-management crew were previous collaborators with both Armfield and Belvoir. In addition three of the actors, Gillian Jones, Russell Kiefel and Kerry Walker were in the Armfield-directed premiere production of the *Blind Giant* in Adelaide in 1983. Therefore the group were quite familiar with each other facilitating the sense of an ensemble.

Armfield began to talk, noting that there was only 'a short amount of time for rehearsal.' The general manager of Belvoir, Louise O'Halloran explained that there had been a 'mix-up' in scheduling and the opening night had been brought forward by one week, reducing the total rehearsal time to five weeks. Armfield countered positively:

All of us having worked together enables us to build familiarity and to work faster than normal.

He continued pointing out to the company that this 'revival' was both:

a way of creating theatre for a large stage [and]  
setting up a new relationship with the writer.

Historically it has been the close relationship between writer and director that has aided the development of both.<sup>35</sup> In response to a

---

<sup>35</sup> Stephen Sewell when working with the Lighthouse Ensemble in 1982 commented that:

Friendship and trust are very important in the theatre ... I now know a group of people in theatre with whom I have had a good working relationship ... [and] ... That's important in the development of a style or angle.  
(in Ridgman 1983: 108)

question from the writer Stephen Sewell, Armfield addressed the group replying that 'Stephen can be here as much as he wants.' This sense of openness was also reflected in the fact that I was allowed into the rehearsal room to freely document the rehearsal process. Armfield introduced me as coming from 'Performance Studies at Sydney Uni' and being interested in 'ensemble.'

As is often the standard practice for a director on the first day of rehearsal, Armfield then gave an introductory talk concerning the nature of the play. He asked the company to imagine the 'dance', the 'physical aspect' of the play and which would make it a 'spectacle.' He then went on to discuss the current context of the play saying that 'the play relates to the Federal Government' but a chorus of actors chimed in saying that the issues were 'more state[-based].' Any illusion that the traditional convention of the empowered director giving *the* meaning of the play to the actors was operating was thus shattered in favour of a more democratic debate. Armfield, unfazed, continued, though 'tacking'<sup>36</sup> to contextualise the play:

The central debate is not current now. The play is about our past from which we can understand Australia now.

Sewell echoed these thoughts:

The reality of financial crises and ecological disasters means that Australia is more unequal today. We have lost our moral authority and we don't know what to do.

Armfield replied that:

The play asks how do you live? How do you express your own sense of right and wrong? [and] We will focus this debate through the fights in the play.

A reading of the play was then begun. In general there was a good complicity between the actors as their consistent joking and laughter highlighted their enjoyment at working together. Hugo Weaving and Cate Blanchett found a good rhythm in their scenes between the ambitious socialist/economist Allen Fitzgerald and the journalist/CIA operative Rose Draper.

---

<sup>36</sup> The director Aarne Neeme in rehearsal at the Centre for Performance Studies University of Sydney talked about how an actor would 'tack' their way through a scene much like sailing a yacht as they attempted to achieve their 'objective.' I use the term here as an analogy to how Armfield attempted to achieve his objective of placing the play into some sort of current context.

Weaving rested his script upon his lap allowing his hands to be free to gesture generously, as he read his lines — a kind of rolling action of his wrists that seemed to be physically seeking out the flow and rhythm of the text. Blanchett's delivery was remarkable for expressing an innocence and vulnerability that was simple, honest and moving. While in the Fitzgerald family break-up scene (Act 3 Scene 10) Peter Carroll gave an impassioned delivery as Allen's father, Doug.

The largely uninterrupted reading completed, what was described as 'script work' in the rehearsal schedule began. Armfield noted aloud the 'difficulty' for the character Doug Fitzgerald to interact with his son and Allen's younger brother, Bruce (Act 3 Scene 12) after the previous violent 'argument', two scenes earlier, when Bruce leaves home. Sewell stated that scene twelve would work, if the debate between Doug and Bruce over industrial action at the steelworks where both worked was kept 'ideological.' However he then openly questioned this statement asking:

What approach should we take? Is this the right approach to take to addressing the play?

Armfield was silent, the ensemble as well. Sewell continued adding: 'having not read it for a while I noticed a nightmare quality.' Peter Carroll responded :

The play has two styles: Naturalism and points of view. As an actor we're psychologically true to the character. My father would never curse in biblical terms which in the play points to archetypes.<sup>37</sup>

For Carroll the 'difficulty' for him as the actor playing Doug was in making the transition from playing an 'archetypal' character at the end of scene ten to playing the same character 'naturalistically' two scenes later. Armfield then suggested that scene twelve would 'work' if it started with Doug attempting to walk away from his son, Bruce. Sewell responded that scene ten was 'non-naturalistic' anyway and that 'dad was God ... [and]

---

<sup>37</sup> In the final speech given by Doug before Bruce leaves home he exclaims for example at the end of Act 3 Scene 10:

May everything you touch shrivel! May all the gifts I gave you turn into barbs to torment you through your life! May the day and the month and the year of your birth be blackened and erased! You were never born! You never existed! I don't know you! You're not my son! (Sewell 1983: 103)

patriarchy personified in a heightened operatic world.' He noted that it could be performed in a 'Brechtian way, by directly appealing to the audience.' However as previously he then openly questioned his own statement asking aloud: 'what is the style', before affirming that Carroll would indeed 'find it in the production.' Armfield himself responded that the 'style' would have to

include ... an inclusive panorama in which detail is as important as broad strokes.

Specifically Armfield referred to a 'style' that would be all encompassing, that would include not only Doug's 'biblical references' but the mundane everyday aspects of life such as 'washing the dishes' by Doug's long suffering wife, Eileen.

From questions on characterisation and style Armfield then shifted the discussion by commenting:

We need to understand the political background of the play.

He continued, citing as an example of the political symbolism in the play, the painting of *St Anthony's Temptation* that hangs in Allen's office:

The Bosch painting is an image of the Blind Giant which is the Working Class.

Sewell in turn replied, rather illuminatingly:

There are three Blind Giants in the play: the Working Class, Capitalism and Allen.

Armfield then shifted the conversation again by asking the actors to 'talk about the plot meanings. Anything you're not sure about.' Peter Carroll immediately stated that he was 'confused about the political plot.' Armfield responded:

Detail shouldn't get in the way of the overall shape. Watching one person who has a job that one wants is emblematic of the play.

He then returned to a question of characterisation, asking:

At what point does Rose become personal? [And] Is there a difficulty with her suicide?

Rose Draper is a journalist/secret service agent who in the course of the play has an affair with Allen, before setting him up and then committing suicide. Keith Robinson stated that 'Rose can't express love' which led Cate Blanchett, the actor playing Rose, to firstly say: 'she has a desire to express it' and then to allow herself the time to experience it for herself in rehearsal by adding: 'I don't know yet.' According to director & clinical psychologist Stephen Aaron 'actors go out of their way to avoid such "result playing"' because there is a 'fear' that 'too early' a commitment to line readings would 'freeze the moment ... and cut off ... further exploration' (1986: 5). Blanchett was certainly allowing herself time to explore what her character could or could not express. In Aaron's words, an actor can only create 'meaningful effects' as 'the result of an inner creative process' (1986: 5). Blanchett's process so far and that of the company had been a free-ranging discussion, where anyone could contribute, however character could be discussed but not decided upon as this was too 'early.' Sewell concluded the discussion of the Rose character adding that she was a 'scorched soul', that there was a 'Beirut-CIA connection' for her and that she was in a 'state of shock.'

Armfield, in response to Sewell's earlier 'nightmare' reaction to the reading of the play, then asked Sewell:

Anything you wanted to change given you had a shifting response to the reading?

Sewell then elaborated upon his previous question about the 'right approach' to the play by highlighting a potential swamping of the human drama of the play through ideological debate. He unreservedly questioned his own writing, stating that he wasn't 'sure about the rhetoric and the ping-pong dialogue.' Hugo Weaving added that:

The same thoughts occur with different characters in different scenes. The way ideological argument spreads is troubling as it abstracts into a world view. It becomes the two voices of control and anarchy in act three.

Sewell concurred with Weaving stating that: 'ideology takes over and humanity is squeezed out.' His initial concern about the style of the play was now replaced by a new concern, about the actual

argument of the play. He openly asked the company:

The crucial question is are human beings the construct of ideology?

And drawing on Armfield's question of when does 'Rose become personal?' asked:

Where is the human element revealed?

Armfield responded that the human element would be revealed by the cast when several characters were shown to be in a paranoid spin. Russell Kiefel, the actor playing Michael Wells, Allen's political rival then asked if 'Charlie Parker [was] the spin out for Allen?' Armfield responded that: 'the guilt of having been to the brothel for Allen is a thrilling sin.'<sup>38</sup>

The discussion continued:

Sewell: These people are characters who want to deny who they are.

Kerry Walker, who was cast as Eileen, Doug's wife, disagreed, stating: 'no some of us want to reinforce who we are.' Sewell and Walker then agreed, to 'reject the motive of subjugation.' However Armfield countered with:

The reality is that Eileen is mad denying the reality around her.

Armfield was no doubt referring to the fact that Eileen has accepted her submissive role in the household for forty years under Doug whose patriarchal, catholic and warrior-driven ideology dominates. And which has ultimately resulted in the death of their middle son, Frank, in Vietnam. Armfield continued, supporting Sewell's earlier 'denial' contention:

People deny what they are. You agree to not let your teeth get kicked in in order to survive. Like Doug and Bruce.

---

<sup>38</sup> In order to take over the left of the Social Democratic Party Executive, Allen does a deal with the heroin-trafficking and gun-running Charlie Parker in the first act of the play. In the third act he reveals to his younger brother Bruce that to 'celebrate' the 'agreement' with Palmer he was invited to the latter's 'best whorehouse' (Sewell 1983: 121). In retrospect, Allen's deal with Palmer is a major turning point in Allen's journey through the play as he betrays both his social and political morals in the process.

Armfield is referring to Doug's acquiescence as a subjugated worker for forty years at the steelworks and to Bruce blindly obeying his father in the early course of the play. When Bruce stands up to Doug in scene ten of the third act both he and Eileen have a revelation as to how Doug and his continued quest for an idealised manhood have destroyed the family.

Peter Carroll then asked a general question relating to the positioning of the actor in regards to their character 'do you judge the character?' Keith Robinson replied that 'of course we do.' Kerry Walker then implored the company of actors to avoid casting a personal judgement over the characters but to 'let the audience' decide. This comment no doubt borne out of Walker's considerable experience seems on the one hand to approach an almost Brechtian tenet of holding the character up for an audience to judge while on the other to reflect Blanchett's concern to not fix the 'reading' of the play's characters too soon. Armfield closed the day's work, summing up with:

I've been knocked over and kept falling ever since is the essential experience of the play.

This is a line exclaimed with anguish by Allen to Bruce in the third act and refers to Allen's self-realisation that the soul is 'poisoned' from the 'moment it's born' and that the 'illusion of freedom created by capitalism' was something that was shattered once he had made the deal with the criminal, Charlie Parker.

In regards to the rehearsal process of the Company B ensemble Armfield has made the following general comment:

We try to be relaxed as possible ... so that each moment that reveals itself can be a doorway from which to explore beyond that. It's all to do with creating a work atmosphere in which you feel anyone can say what they think.  
(in Stewart 1995: 16)

It would seem on reviewing this, the first day of rehearsal, Armfield did just that: set up a 'relaxed atmosphere' that encouraged genuine debate following the reading of the play.

Armfield has also said that there is 'no formal pattern' in the 'script work' part of the rehearsal period but rather:

cross-referencing amongst each other in all sorts of funny ways so the whole group gathers an understanding of the collective life of the work. (in Stewart 1995: 16)

However, within the 'relaxed' feel of the rehearsal room, Armfield has carefully guided the debate through various questions of characterisation, 'style, plot meanings' and 'political background', the structure of which has an informal formality about it. He has used these questions about the play to articulate both the concerns of the writer and the actors and his own particular views. That the debate was open to anyone within the company to comment would seem to support Armfield's own view of his methodology that encourages a search for a shared 'understanding' of the meanings within the play by the company. This view was clarified to me three days later by Peter Carroll when he explained to me that the company's script work was a search for 'a collective understanding' of the play. He commented that what they were doing in the first week of the rehearsal was the 'same as in *The Tempest* and that's why the Shakespeares were so good.' However while the interactive nature of the debate was democratic it would seem that the subject matter and the direction it took was essentially controlled and guided by Armfield whether in response to questions from the company, or his own.

### **3.2. The Design Presentation: in Search of a 'Found Quality'**

At 10:15 A.M. on the second day of rehearsal Stephen Curtis presented his design. As we all crowded around the set model, Curtis related that 'working from previous work with Neil' meant 'presenting the actor, the characters strongly' and achieving 'the flow of action from one scene to another.' He continued saying that it was 'such a big play the action can't stop for furniture' and therefore the intention was to create

a space that things can happen in ... that relates to the world of steel.

Metaphorically it would be:

An image of Australia that has fucked itself over [where] it's not worth building on [and] a cold wind blows over an empty desert.

In practical terms it meant:

A red wall like the heart of the steel mill, fog, shafts of light, a workbench that slides [and] a couple of chairs.

that would made up a 'working world' for the actors to work within. He added that at the 'end of each act' there was a correspondingly 'big moment.' He specifically cited the 'accident scene' at the end of the first act and proposed 'that the floor be lit with a lot of light' while the actors would 'find the action for Bruce to escape with' (from molten metal) in rehearsal. Similarly it would be the actors' responsibility to 'find' the means for 'Ramon's exit' from the theatre onto the street outside, in order to convey his fall into molten metal towards the end of act three.

In response to a question from Keith Robinson about what the floor would be made of Curtis replied 'an uneven gloss over concrete.' Armfield immediately chimed in joking, that, that was the 'difference between STC and us, a crappy black finish.' Curtis then described the 'workbench' in more detail as a 'table' on wheels, having an 'elegant feeling' that initially slides along the main wall of the theatre before it 'breaks free and is hurtling around space for the train' in Act 1 Scene 3. The table was thus designed to be multifunctional. In Patrice Pavis' 'procedure' for

analysing the 'function of ... objects' in performance, the table would be: 'basically functional' (to be used as a table), indicate an 'actual location' (by becoming a train) and 'symbolize' Curtis' hard-edged 'world of steel'; even its colour, black was arguably 'caught up in a poetic network' — a 'metaphor' for "blackness of soul" (in Helbo et al 1991: 142).<sup>39</sup>

Curtis then added that: 'The table shouldn't move back to the same position for scenes' between the same characters. Hugo Weaving in turn clarified this asking:

You mean play scenes where the table ends up for Allen and [his wife] Louise?

Armfield responded:

The shape has more to do with the obstruction and the [associated] dynamic.

Curtis confirmed this adding:

The way the action is pushed around forces a dynamic, an element that you have to work around.

The table, it should be revealed, was long, narrow and rectangular in shape and had the potential to dominate the upstairs stage at Belvoir. Armfield then explained that this 'dynamic' born of 'obstruction' was 'the same as the carpet and trestle in *Hamlet*.' Armfield has previously related that through the use of a rectangular Persian carpet in *Hamlet* the company was 'able to change the space ... from act to act' and that 'the way the carpet was used was the spring of action' (in Golder & Madelaine 1995: 72).<sup>40</sup> Curtis added that the actors for example 'could play a scene at the front of the table.' Armfield elaborated on this saying that the table could be on any angle. Once it was 'free at the end of act one', it wouldn't go back to the same position. He concluded that

---

<sup>39</sup> Patrice Pavis writes that:

any object in a dramatic text ... is a metonymy of ... element[s] of reality (a bunch of wild flowers for the country ...) or a metaphor (a black costume for "blackness of soul" ...). (in Helbo et al 1991: 142)

<sup>40</sup> In *Hamlet* Armfield has said that he directed the actor Richard Roxburgh to use the Player King's speech on the carpet as creating a 'memory' with which he, Hamlet could later 'toy' with by directly looking at, walking around and standing in the middle of the carpet (in Golder & Madelaine 1995: 72).

there 'was no point in having rules' on how to work with the table but rather, you could 'make it up as you go along.'

Peter Carroll expressed a concern that while the play insisted on 'emotional plotting of space', this set was more 'fluid' and as a consequence it 'gave up specific locations.' Armfield replied that it related to 'the sense of the nightmare' of the play, echoing Stephen Sewell's response to the first reading of the play the previous day. Curtis then explained the rationale for the design by commenting on the Sydney Theatre Company's production of the *Blind Giant* which he thought had mistakenly tried to:

create miniature worlds for each scene. Not only did it slow the action down, but by tying the emotional reality of the scene to too much mincy detail, we lost the big picture.

Curtis however also added that he 'appreciat[ed] the need for you as actors to know precisely where you are.' Carroll responded that it depended upon the "actors' temperaments" and the 'props' some actors needed to give them a sense of a specific location within a scene. He added that in view of the 'fluid' nature of the design he was prepared to work through this, 'to confront ... discuss ... and then discard' the 'mincy detail' in favour of the 'big picture.' Armfield commented that:

It was the same with *The Tempest*, open locations ... which makes demands upon actor's temperaments.

Curtis added that the set reflected the 'industrial world' of the 'workers' whom he associated 'the stakes of the play with' and that the bench could be seen as an 'image of labour.' Armfield then rounded off the discussion of the set design by explaining that the 'purpose of the space and the moving parts' within that space was to 'enable the physicalisation' of the play. He asked the company to 'visualise the dance of the play.' On day one of rehearsal he had asked the company to 'imagine the dance of the play,' now he wanted them to see it.

Armfield then introduced Eadie Kurzer, the costume designer. In some detail Armfield explained the costume design philosophy that would inform the production:

The processes of working on *Dead Heart* and *The Tempest* ... with Eadie [meant] costumes were being designed through the rehearsal process.

Armfield added that the actors first had to 'create a state' for their character 'to be in' and that:

Once the characters were worked on clothes were being designed around that activity.

It was a 'found quality' that had been achieved and to Armfield the 'optimum costume design happened as late as possible.' With a sense of irreverence, he cheerfully concluded that it was 'really good Eadie hadn't got anything.' Kurzer had however 'visualised' the look of the costumes, to use Armfield's term. She said that it was:

beyond naturalism [a] loose time from 1976 to 1981 [of] different hairstyles and silhouettes, flared trousers, wide lapels [and] broad ties.

The party scene was however 'very specific' while 'dark blue boiler suits' would give the workers 'unity and anonymity.' Armfield expanded on this design vision stating that it was 'more useful to think of what works. Don't intellectualise.' They were looking for a

found vision, a sense of being both in the theatre and in real life ... a found look which has theatrical life through which we tell a story.

He added that there would be 'clear references' to both the State and Federal Labor Party. What this meant in real terms was, for example, 'Allen's jacket from the 60s' which he still wore and which 'worked from memory' and is referred to directly in the text of the play. Clothes would not be strictly 'accurate' or about 'naturalism' but have a 'symbolic value.' Kurzer added that they would:

achieve the look through having a general talk about style [and] speaking to the individual [actor].

They would then either buy or make the clothes as required. Armfield commented that 'some clothes and haircuts refer to where they [the characters] come from.' He cited Doug and Eileen as an example of 'referring' back to the 1950s.

Paul Charlier the sound designer then spoke about the sound he was looking for. He explained that he had been down to the steelworks for sound but it was 'hard to use' because of its 'epic quality' and it would 'wipe out' what was a 'dialogue-driven play.' Armfield responded that he preferred:

the idea of a drama that was more musical in its construction. [And] If we do plunge into the industrial world it is overwhelming, powerful and short. Like in act one.

That completed the design presentation which had taken less than an hour but had significantly framed the means of developing the stage action through a proposed open set that a large table would roll across. This key design element was a given, a construct of the designer prior to the rehearsal and not unlike one of Anne Bogart's 'acts of violence.' The distinction in the design process that was made by direct comparison with the Sydney Theatre Company's production of the same play was to focus the action on the actors, rather than the set itself. It was intended to support the actor through its mobility and ease with which it could alter the performance space. How this table would be manoeuvred from scene to scene would be 'found' by the company in rehearsal. Similarly what the actors would wear would be 'found' once they had established their character. Armfield's insistence on an almost holy 'found quality' is perhaps reflective of how he wanted to create a rehearsal structure with a sense of freedom, an allowance for exploration despite the limitations of an already shortened rehearsal period.

### 3.3. The First Run of the Play

Following a week of 'script analysis' the full company was scheduled to run the whole play. Immediately after a lunch break on day six the company gathered on the rehearsal floor, but with Armfield initially absent. Peter Carroll interrupted the *bonhomie* of the company urging the cast to focus on the upcoming run saying: 'c'mon we've got to get our act together.' Kerry Walker responded that they couldn't 'do anything without a director.' Russell Kiefel then asked whether they were 'going to do all this standing up?' Armfield arrived and stated that the purpose of the run was to 'free up the play' and for the cast to 'feel' themselves in the 'space' and to 'create' their own 'images.' Kiefel then stated that it would be 'good' if they 'could sit around' together and do the run. Armfield countered, advising them that they would do the run 'standing up.' He asked them to 'be bold' and added that they would 'have to create their own scenes' and wouldn't 'get any help' from him.

The run itself was characterised by a casualness as the actors simply came on from whichever side of the rehearsal room they found themselves on. The run gained much of its drive from Weaving who featured in more scenes than any other actor. It was from the latter half of the first act that his intensity and that of the play notably increased. The first two acts were run through without a break while a ten minute break separated the second act from the third act. At 5:30 P.M. the run was completed, three hours after beginning.

The run was most significant in terms of the discussion that immediately followed it and which highlighted scenes that the actors themselves felt difficulty with. Gillian Jones, playing Jane, suggested that they 'cut all the Jane and Louise scenes.' In the play, Jane is a friend of Louise and acts as a confessional support to Louise, as Louise deals with her failing marriage and the affair that her husband, Allen has with Rose. Stephen Sewell argued that what he 'liked' about these scenes was that they provided a 'structural thing ... a sort of stillness within the storm.' Catherine McClements, the actor playing Louise, however, agreed with Jones, stating that it was a 'problem as you still

have to play that turmoil.' Peter Carroll agreed, commenting that he felt:

when people were fighting they had somewhere to go, when someone wanted to help [as in the Jane and Louise scenes] it atrophies.

Armfield after allowing the debate to run its course, advised that it was too early in the rehearsal period to decide on this. However these scenes would indeed be later cut from the production by Armfield who would support the actors' concerns and gain the writer's support for such a cut, despite Sewell's initial favourable response to these scenes. Armfield himself expressed concern with the 'troubling' scene where Louise confronts Rose over her affair with Louise's husband, Allen, which in his mind started well and then lost its hold. Keith Robinson echoed these comments stating that he 'found it hard to believe that Louise would go to Rose.' Similarly, this scene too would ultimately be cut by Armfield following consultation with Sewell as well.

The run at this an early stage of rehearsal had arguably proved valuable in both allowing the company to view the play in its entirety thereby facilitating the editing of what is in script form a lengthy play and allowing the actors to create the first physical impulses for the blocking of the play. It is interesting to note that just momentarily Armfield had handed the whole play to the cast to run by themselves. It is an action that doesn't normally happen until later in the rehearsal period when the director, having blocked the individual scenes with the actors, then gives the play over to the cast, for them to run and to take responsibility and ownership of the production proper. In an analogous fashion, over the ensuing three weeks of rehearsal Armfield would often direct the cast to initially run a scene by themselves before he would work through it in detail with them. One could speculate that Armfield both in his approach to this first run and the blocking of individual scenes was actively soliciting the first impulse from the actor in how they chose to move in a scene. The actor's chosen action thus revealed, Armfield would then be in a position to variously build on the actor generated image or create a new one.

## 4. ESTABLISHING THE MACROSCOPIC WORLDS OF THE PLAY - THE 'COMPANY' SCENES IN ACT 1

### 4.1. The 'Train Scene'

Following the design presentation on day two of rehearsal the company read and briefly discussed the third scene in the first act (Sewell 1983: 5-6). In the extant script the directions for the scene state:

*An underground railway station. ALLEN ... is on his way home ... a sense of ALLEN'S isolation and a perception of general social breakdown. ALLEN walks past a series of disturbing vignettes, with the rhythmic sound of a train ... adding to the atmosphere. (Sewell 1983: 5)*

Seven '*vignettes*' or '*images*' are then clearly delineated in the script. Armfield commented that the company could 'explore' these images of social breakdown described by the playwright or alternatively 'more potent images' could be 'found.' Sewell concurred with this comment. Keith Robinson suggested he operate a follow spot on the action to which Armfield responded that he preferred all the actors to be on stage together:

for everyone to be involved in this scene and to create the feeling of the train.

Peter Carroll then suggested the idea of being on a 'platform' which was to him more 'menacing' than being on a 'train where 'you're going somewhere.' Armfield in turn suggested you may be able to get this feeling through Allen 'walking through the length of the carriage.' Hugo Weaving seemed to side more with Carroll in leaning towards the image of the underground tunnel at Central Station in Sydney where he commented 'it's echoing and there's a slight sense of danger.' Armfield responded that Allen could be 'walking at a constant speed as the table changes' and in regards to the tunnel perspective alluded to by Weaving the table could 'move up with the image towards him.' This comment by Armfield does not imply the same violent movement of the table Curtis had envisioned as 'hurtling through space' in the design presentation. Nonetheless the seed had been planted for the stage action to indeed 'spring' from the table.

On the afternoon of day seven, the whole cast returned to work on the scene in detail. A working model of the portable table arrived at the beginning of this session. After inspecting the table Armfield posed the following question:

We have to find a way of doing this scene. A question of how we find a theatrical language. We have to find a physical language. What about moving it [the table]? Do we put it [the scene action] on top on the table? It might be be good on the table because it [then] becomes a stage.

Armfield was obviously thinking of the images occurring on the table as Allen walked past them, in an analogous way to how the action had occurred on the carpet in *Hamlet*. Carroll asked 'how does it move' and Armfield replied:

just backward and forward. It should go boing! Down first. Shouldn't it? [It] starts going slowly back then rushes forward. All those involved can push the table. I like the idea of seeing you all push forward.

Whereas Curtis had talked about the table breaking free for this scene Armfield had now limited its movement to sliding back and forth along the main wall of the theatre. Carroll then reiterated the theme of trying to represent the tunnel at Central. Ralph Cotterill in turn asked: 'what is the effect you're looking for?' To which Armfield replied in agreement with Carroll: 'the experience of walking through the tunnel.' Hugo Weaving then sought clarification asking:

You're racing down then [the table] comes back slowly as I'm walking past. Is that right?

To which Armfield agreed. A trial run took place with all the actors pushing the table and to which Armfield commented: 'looked fantastic.' Cotterill then asked: 'where will the images appear from?' To which Armfield replied: 'I'm not sure. The first one appears from the centre' and tellingly added: 'lets not plan too much.' One could speculate that Armfield didn't want to plot the scene immediately and that his expression of uncertainty was a way to gain more time before having to decide where the actors would be located in performing various street tableaux in regards to the moving table.

Peter Carroll, reflecting aloud on Curtis' vision of the table as a 'work bench' and a 'symbol of labour', then stated: 'this table

represents machinery' and asked Armfield with the other scenes to come in mind: 'can you use the table for work and other images?' Armfield responded and seemingly empowered the actors by saying: 'yeah. It's your table and you can create what you want.' Cate Blanchett then reversed Armfield's earlier suggestion of placing the images on the table and thereby making the table a stage by offering: 'I like the idea that Allen is on the table.' And although Armfield quickly replied 'it could be anyone', she continued:

I think it's quite integral to the play that you have someone in need of help and no one acts.

This theme of an individual living in an unsympathetic world is symptomatic of Blanchett's own character Rose Draper, a CIA operative who is desperately in need of help herself. Draper uses and betrays her lovers in the course of her undercover work while being used herself by her employer. For Blanchett her 'vision' of the 'dance' in the scene was for the images to happen in front of Allen who would not move from his safe vantage point on the table, which would now represent the train rather than the platform.

Armfield then asked: 'so how do we set this up' and turned to Paul Charlier the sound designer:

Paul do you want to set something up that's more ordered?

In the stage directions '*the rhythmic sound of a train*' and the sixth image of a busker are indicated. Charlier replied: 'I've got a busker.' He then played a recording of a busker. Armfield responded: 'does anyone play guitar?' Steve Rodgers replied affirmatively and subsequently became the busker. Armfield then followed on from Blanchett's suggestion stating: 'the other thing would be to put Hugo here' and sat himself on the table in a spatial demonstration of what it would be like if Allen was seated there. Blanchett quickly asked: 'shall we see what it looks like?'

After a run through Armfield commented that he was 'not sure about him [Allen/Weaving] sitting.' Jacek Koman commented: 'it's like he's on the train' to which Armfield concurred:

Yes you're like on a passenger train, seeing images pass you by ... I like Hugo as a constant.

To which Weaving replied:

But you said you didn't like me sitting there all the time.

Armfield countered: 'oh I think I do now.' Armfield had indeed taken on Blanchett's suggestion and maybe this is what he was referring to in searching for the 'found quality' previously alluded to — allowing the time within rehearsal to debate and try out various options proposed by the company before deciding upon the action to take.

The images were then blocked in the order and followed fairly closely the directions indicated in the script. However Keith Robinson interrupted and asked: 'Why is this scene here?' He then read the descriptions for the images aloud and responded to the general direction from the writer that there be '*a perception of general social breakdown*' by asking Armfield:

Can you improve on that? It's not shocking for someone from Leichardt is it?

This is probably both a reference to the contemporary street life of Sydney and more pointedly to Armfield who lives in Leichardt. Armfield replied: 'I think the development should be shocking' and this vision then infused the progression of the images as they were fleshed out by the actors under Armfield's direction.

Armfield, having utilised his cast as a sounding board and as a source of ideas for structuring the scene, then returned to the more traditional role of director as coordinator of the stage action as he guided the cast through his vision for these images. To the first image of '*a poorly dressed woman with a baby*' Armfield added in his words the 'frightening thing' of a woman with 'no shoes' who is 'walking through with an old pram' and who in his mind has 'just left her husband.' With this image he suggested to Kerry Walker who was singing *Blow the man down* (as prescribed by the stage directions) '*Zippity Do Da*', but sung 'fiercely' which she enthusiastically accepted. To the second image of '*a derelict with the DT's*' he implored the actor Ralph Cotterill to be 'really frightened by the train.' To the fourth image of '*a drunk evangelist*' Armfield encouraged Peter Carroll to 'spruik' rather than 'offer a warning' (which Carroll had suggested) as the evangelist quotes the scriptures loudly. Armfield then asked why couldn't the sixth image of the 'busker stay' for the entire scene and added 'he could frame the whole thing.' A progression of images of a chaotic, uncaring and

sometimes dangerous world was thus developed by Armfield which well illustrated Sewell's intended sense of social breakdown while taking some of the playwright's images a step further. Armfield had achieved this by variously adding a prop, the pram and constructing a 'where have you come from'-type background, for the first character — a fairly standard psychological approach to character and counterpointed with a song usually equated with happy times and alienated by its positioning with such an image. With the other images Armfield had employed both physical and aural blocking to structure what would happen in the scene.

Over a number of consecutive runs, the table was then pushed forward and backwards with Hugo Weaving seated on it. Each time the table was pulled back upstage the actors, acting from Armfield's instructions would either jump under, over or around the the table and then complete their image downstage before exiting (see Figure 1.). The table was like a curtain opening and closing as these images of social breakdown were consecutively performed, until finally Allen was alone on the table which he then moved into the position for the next scene with his wife, Louise at home. The table had become a carriage with Weaving sitting on it, like a commuter, while the stage in front of the table became the platform on which the images would be performed in front of him and the audience. This use of all the actors in pushing the table and then performing the images in front of Allen was in Armfield's words the 'way' the company had 'found' how to 'do the scene' — a total working integration between the company and the main movable set piece, that had developed from a blocking structure proposed by the actor Cate Blanchett and subsequently directed in detail by Armfield.

A discussion then followed which explored whether the whole company was on stage from the beginning of the play, watching the action or if they all entered on scene three. This idea of establishing for the audience the sense of an actors' ensemble who were going to 'tell a story' seemed very important to Armfield as it was a convention he had utilised in the company's production of *Hamlet* and represented his larger aim of

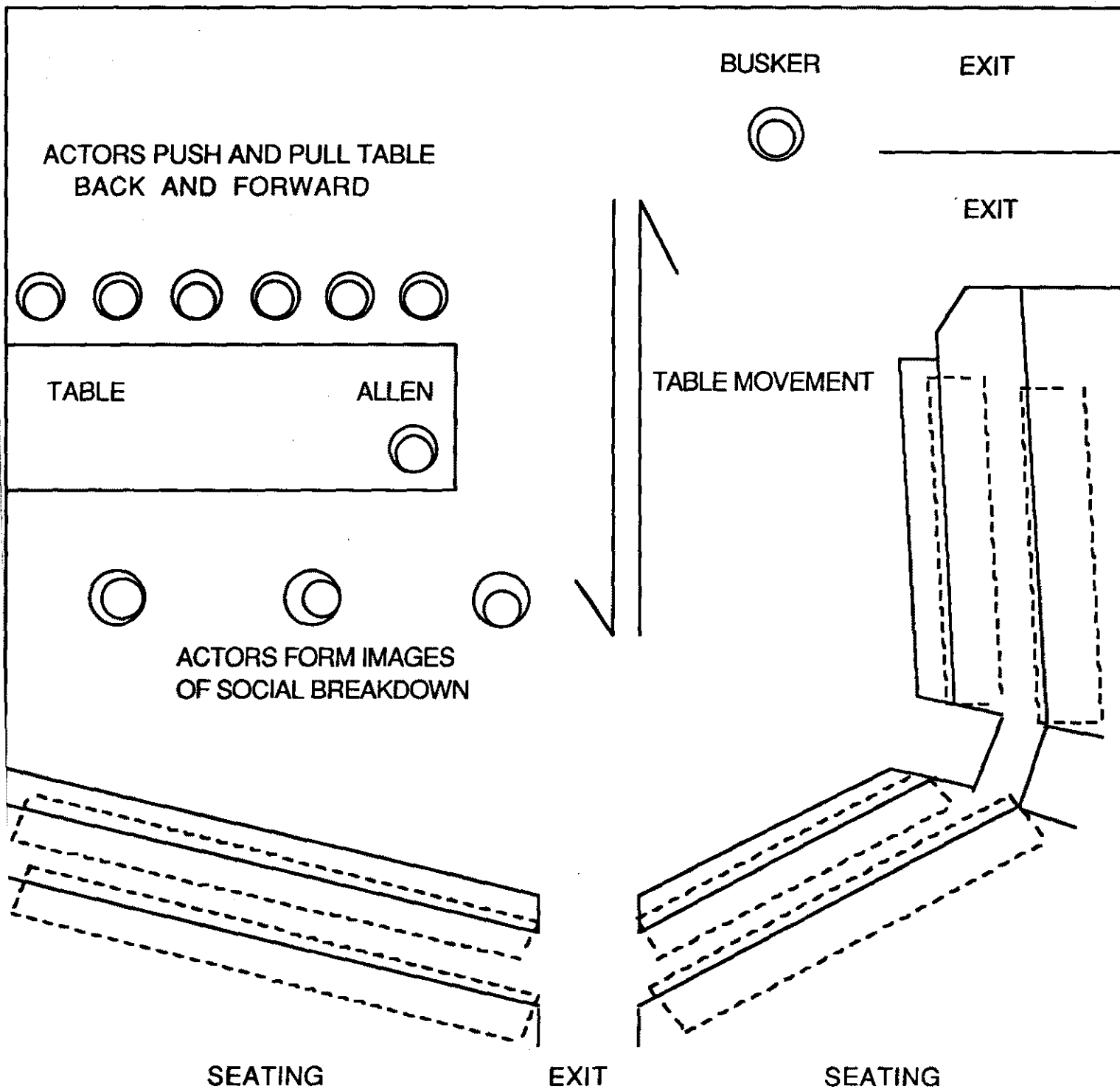

Figure 1. The 'train scene' (Act 1 Scene 3). Allen sits on the table, which becomes a carriage and is shunted back and forward as images of social decay are performed downstage.

creating an 'actors' company' (in Golder & Madelaine 1995: 80). It was achieved in *Hamlet* through a prologue that enabled a 'shared moment of presenting all the actors' to the audience at the beginning of the play — a separation of the play and its characters from the company of actors who were 'going to do it' (1995: 73).<sup>41</sup>

Upon reflection it would also seem to be analogous to the notion of the chorus in Greek theatre setting up a strong focus on actor-based story telling through an initial mass physical presence. The importance of this company convention to Armfield was underlined by his open question to the cast:

The fundamental thing is do we have the whole company watching the first scene?

and his comment that rather than the audience simply identifying with the characters of the play that they be reminded that 'you are actors who are telling a story' — a Brechtian sense of separation between actor and character. Kerry Walker however commented that she felt this didn't work in the *Blind Giant* because unlike the prologue in *Hamlet* the cast had 'nothing' to do while the first two scenes were played in front of them. Keith Robinson agreed stating that having all the company watching the opening assassination scene would 'drastically alter the thriller genre of the scene' while Cate Blanchett also said that she felt 'strongly against it.' Armfield however insisted that they try it 'first' by simply walking on and forming a line of at the rear of the stage. As Armfield then tried to coordinate actors leaving and returning to the line for the first two scenes he at first asked the company to 'be quiet please' and then simply told them to 'shut-up!' He concluded disappointedly that it was 'no good' as the actors simply looked like 'furniture.' He then turned and asked the observers and stage management what we 'all' thought? There were two affirmatives and two negatives. It was a question that would not be answered until the company had worked on the train scene again immediately after they had run the first act for the first time, three days later on day ten.

---

<sup>41</sup> Golder and Madelaine write that:

Armfield's *Hamlet* began with the full cast assembled on stage ... Horatio came forward to deliver lines transposed from the final scene together with lines from the prologue to the play within the play ... this device established Shakespeare's tragic world ... what this company of actors will enact for us ... (1995: 56)

After this run of the first act Armfield, seemingly still concerned about whether they had found the best solution to blocking the scene, had asked:

Can everyone put their thinking caps on about this train.  
Are we doing it the best possible way?

A lighthearted repartee and banter between two of the actors followed:

Keith Robinson: What's wrong with it?

Hugo Weaving: It's shit [Laughs].

Armfield countered, pulling and focussing them into the task, advising that the images of social decay needed more focussing. The actor Gillian Jones suggested:

Maybe we should have more of a Bosch image with something happening in every corner?

and which Peter Carroll supported:

[What about] The concept of using the whole theatre?  
I had the vision of things happening by the wall.

Armfield however disagreed commenting that he wanted:

A still field where we're looking into his [Allen's] head.  
[and] I don't like things happening around the audience.  
It splits the focus.

This 'still field' is representative of Armfield's self-proclaimed search for a 'still point of clarity' that is brought to 'life' on the stage (in Stewart 1996: 16). It signalled a rejection of this new and alternative blocking proposed by two of the actors. Critically it was Peter Carroll a senior member, like an elder of the tribe who then underlined for the company to follow Armfield's direction; that is, accept his decision and the need to therefore focus the imagery by foregrounding the actor's time and concentration on the company's existing action. Carroll commented that the table was a metaphor for a 'nightmare' and that the action in the scene had 'felt too rushed' and there should be 'more interest in the company running on and off' as the tableaux of images of decay followed each other. It was a

comment that was reflected by Armfield's general note following the run of the first act:

It's really important to keep the focus on the people who are carrying the floor.

This growing concentration on the actors' action in telling the play's story on stage, in turn provided the answer to the unresolved question of whether the company would all be on stage from the first scene. Armfield commented:

I'm not sure if the scene of the company opening is OK. It doesn't feel so good for the Wells and Carew scene (Scene 1). It might be better to keep you all off until the train scene (Scene 3).

Kerry Walker echoed Armfield's comments stating:

It felt very strange looking at Carew and Wells.  
I felt it might have looked better if we didn't look at them.

Hugo Weaving in turn responded:

I think if you're in there you have to look, otherwise you draw focus.

To conclude, it would seem that in the absence of a specially constructed prologue and in order to allow the 'focus' to be on the individual scenes themselves rather than the company of actors presenting them, a formal introduction of the company to the audience was thus abandoned by Armfield with the voiced support of key experienced members of the ensemble such as Kerry Walker. While at least three of the actors had always been in favour of this outcome it represented an about face for Armfield and some indication of his flexibility as a director as he abandoned a company convention that he was very keen to maintain.

## 4.2. The 'Party Scene'

The approach to constructing the 'train scene', the first of the 'company' scenes, was something that Armfield used as a benchmark to refer to when the company worked on the next group scene. On day eight work began on act one, scene six (Sewell 1983: 14-26) which in the stage directions is listed as a '*bourgeois party*' and which became known to the company as simply the 'party scene.' It is a fortieth birthday party for a former university friend of Allen's, Bob Lang who is now a '*bourgeois economist and banker*.' The scene sets up variously, the political and social differences between Allen and Bob Lang, the fight for the control of the ruling Social Democratic Party between Allen and the secretary Michael Wells and the beginning of the relationship between Allen and Rose Draper.

The company was specifically looking at the entry point into the scene. In the text the directions state: '*guests are standing, talking*' though it soon became obvious that Armfield had a more energised entry in mind. He stated that:

The purpose of this entry is to show the society at play. There's a burst of energy at the end of the previous scene ... a tableau ... [and] it's another company scene.

By 'company scene' Armfield inferred that all the cast would be involved as they had been in the previous 'train scene.' He continued with what seems a recurring pattern, that of first asking the company how they were going to do the scene: 'what interesting movement could we do' and then answering himself: 'it would be nice if everyone runs through and pushes on' to the stage. Armfield subsequently showed the cast what he had in mind running onto stage and adding: 'all spill out here and party.' Peter Carroll, watching Armfield gyrate on the rehearsal floor, laughed loudly and to which Armfield responded: 'that laugh's good' and then added 'let's just see what happens.'

The company ran through the entrance, which was distinguished by a big laugh from Carroll who had good-naturedly taken on Armfield's previous encouragement. Armfield then asked the company to 'freeze' in a line, to form a 'tableau' with the initial focus on the centre group of three actors. He added: 'it should [then] go into conversations, drinks and smoking' and asked the company to explore: 'what level of focussed partying happens.'

A difficulty then arose in the chorus of party goers taking away focus from the central characters engaged in conversation downstage, Allen and Rose Draper, then Allen, Bob Lang and his wife Janice. Armfield with this in mind asked:

What's it like if you have silent conversation with body gestures?

and added:

[It would] be nice if we could find a stylization that is meaningful to participate in so you're not just wallpaper.

It should be like the train scene. The ensemble acting is meaningful and interesting.

Peter Carroll responded asking:

You don't want a linkage? So we're all having conversation with an imaginary person?

To which Armfield replied:

Maybe just for the moment work on separate activity and find [the] essential thread of party behaviour. It gets boring if you get bored ...

[Try to] find [some] little action or you're listening to what's happening down here [pointing to the central characters downstage].

The scene was run and it seemed to me that the chorus of party goers looked like they didn't know what they were doing and, being upstage, seemed isolated from the action downstage. Keith Robinson asked the question: 'are we as individuals changing shape ...?' To which Armfield rather enigmatically replied:

You'll feel it when it works. It seemed to work for a while then the ... interaction became meaningless [and] didn't give the landscape of the play.

More specifically he pointed out to Carroll:

Peter I missed the feeling you coming out of an interesting conversation.

and then added he was looking for something akin to the Cazneau photo of *Waiting for the bus*. Carroll in turn asked whether Armfield wanted the chorus 'closer' together like the 'photo' to which Armfield replied negatively and concluded: 'keep exploring it. We should push on.'

The motivation for the chorus became much clearer in the third part of the scene when Allen has a verbal showdown with his rival for the control of the ruling Social Democratic Party, Michael Wells. The following conversation occurred between Armfield and the cast:

Armfield: Every time Wells cracks a joke he looks for someone to laugh with.

Carroll: And we do.

Armfield: Yes.

Armfield: [To Russell Kiefel playing Wells] It's good if you use all the the party and look them over.

Armfield: [To chorus] It's a very interesting meeting which you've all been waiting for.

If Michael Wells looks at someone you all look.

A clear focal point was thus given to the chorus consistent with Armfield's comment on day one that they 'would focus the debate through the fights in the play.' Armfield then focussed the fight even more clearly by placing Kiefel in front of the chorus of party goers, facing Weaving while encouraging Weaving to address Kiefel and the chorus as a whole (see Figure 2.). It was not unlike a classical Greek theatre structure with a rival challenging the King with the King's court immediately behind him and in support. After a run of this part of the scene Armfield concluded: 'that it seemed OK' and moved on to the next scene to be rehearsed.

However the first part of the scene remained troublesome as was revealed in the first run of act one two days later on day ten. As the act was run Armfield side-coached directions to the company:

Dance to the audience Gillian. Aren't you all supposed to freeze?

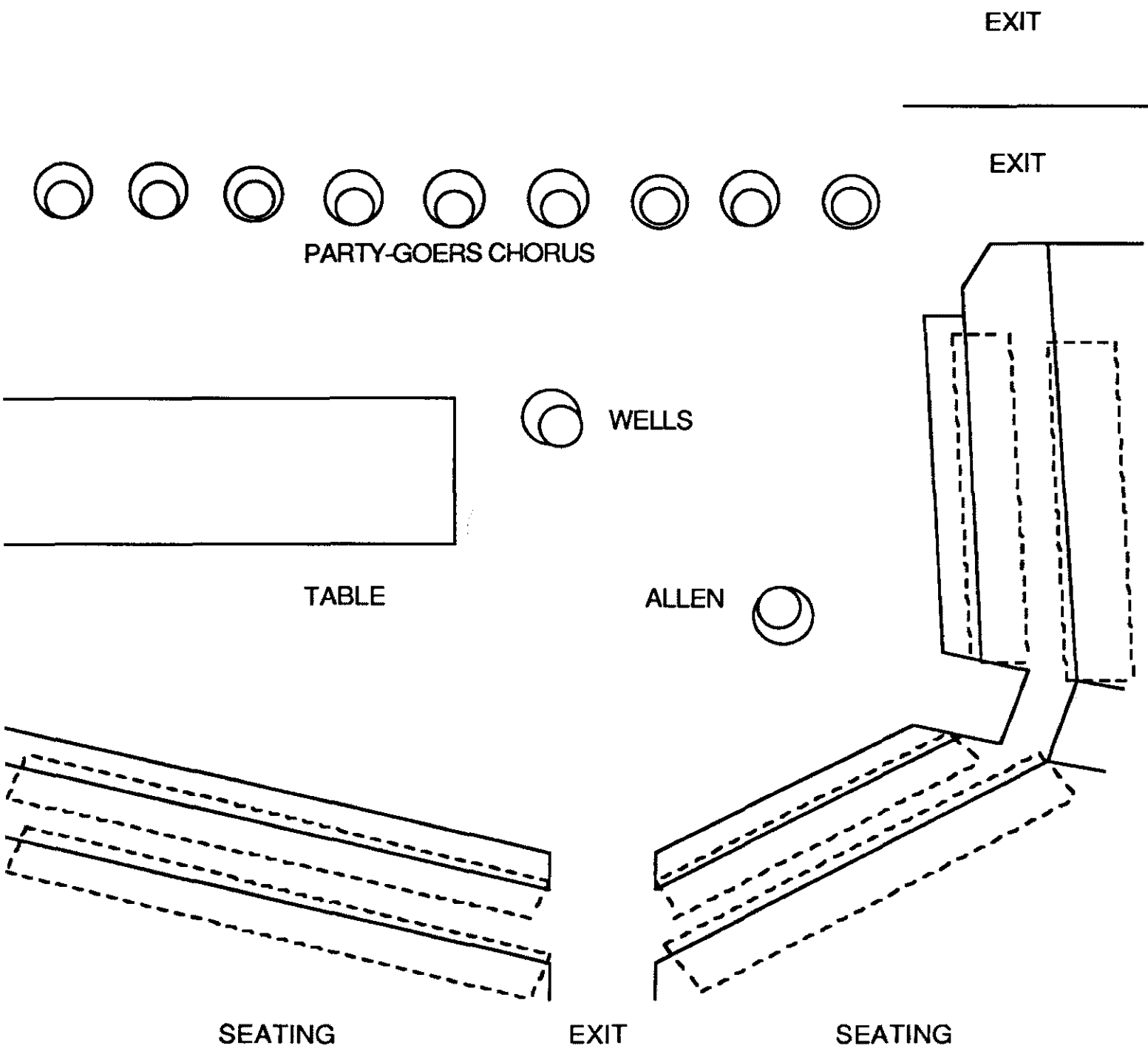

Figure 2. The 'meeting' between Allen Fitzgerald and Michael Wells during the 'party scene' (Act 1 Scene 6).

Kerry Walker responded:

If we make a mistake you have to call out, you're the director.

This throwaway comment by Walker, a long-time collaborator with Armfield, is indicative of how she would continually throw gentle digs at him in the course of this rehearsal process while at the same time acknowledging her need for his assistance. Armfield was unperturbed and, perhaps, one could surmise, accustomed to such regular irreverent reminders of his function, from a trusted colleague. He simply replied that he knew he was the director and continued on, telling Steve Rodgers to 'stop!' moving and Ralph Cotterill to 'just freeze out front' and then to follow the others when they start to dance. In the notes following the run, Armfield stated that he

thought there was a growing concentration from what Steve brought into the party scene

Steve Rodgers was playing Bob Lang the banker with an nihilistic enthusiasm. Armfield continued:

It grew from that. It's wonderful. It feels like the play is moving in a behavioural way, a Belvoir feeling of [both] surrounding the action and seeing the detail. [We're] not simply playing into the genre.

He then asked if there were: 'any thoughts from the floor?' The following discussion revealed the cast's unease with the scene:

Keith Robinson: I'm unclear of where we're freezing and moving.

Armfield: There's got to be more exploration of a bourgeois party

Gillian Jones: It's very difficult to do on stills.

Armfield: Go on searching for a way to break the convention. It's a problem of time I suspect. We'd need a week to explore that rather than find an instant solution.

It was a rather insightful moment into the pressure Armfield was really under, to deliver such a huge work in five weeks while

finding for him a genuine rather than 'instant solution' to shaping the scene. The discussion continued:

Catherine McClements: I feel it should be more debauched wildness [which] we can't do in stills

Armfield: It has to be painted in three tableaux. I'm getting a distinct sense of behaviour from Peter's character — it may be making it a clearer definition of each character.

Russell Kiefel: We're not sure what we're trying to achieve ... I feel like we've only scratched the surface.

Stephen Curtis: [It has] the potential for a real release.

Armfield: We'll work on it.

True to his word Armfield did return to this scene two working days later (day twelve) immediately prior to the second run of act one. The scene was first run through at it was and then Armfield addressed the cast:

Now we're going to try a simple dance step that Peter will show you.

As he spoke he demonstrated a shuffle of the feet.

Your head is free but you must always keep your eyes on the scene. You can twist, you can do whatever you like but the purpose is not to draw attention to yourself but to give focus on the other side [of the table]. Don't look at each other. The dance should relate to your character.

It would seem that Armfield and Carroll had conferred to bring some structured action to the scene. Armfield then worked with the company on the entry of the chorus of party goers to the scene. Following a noisy and enthusiastic entry by the cast which Armfield didn't like he asked the company to: 'all run on without noise as part of your dance.'

After the scene was run through a couple of times Armfield suggested that the cast would freeze as the accompanying music cut out. He continued to work on the scene despite a high level of chatter amongst the company and while three of the cast were throwing and catching a tennis ball behind his back, much like school children playing under the nose of their teacher. It is

likely that Armfield consciously allowed this childlike quality of anarchic play in rehearsal as a way to allow the actors to have fun, to retain their creative spark and to avoid boredom and which would in his mind contribute to what the company could achieve with the play.<sup>42</sup> There was, however, at times a fine line between creative play making and time wasting; with only five minutes left to work on the scene before this second run through of the first act Armfield abruptly directed the cast to 'shut-up!' He then however immediately reclaimed the playful atmosphere of the room by laughingly asking the cast to consider:

What do you think this looks like to The Sydney Morning Herald? Chaos! [Geraldine O'Brien from the Herald being present in rehearsal]

The subsequent second run through of the act showed a scene in its early days but rough around the edges. The two 'freezes' worked well, but there was variously too much movement and not enough focus on the central characters. The showdown between Allen and Wells was good but the chorus reactions were muted, irregular and lacked uniformity. These were all the things that Armfield had asked for and only partially achieved. This may indeed reflect the time required to work in detail with a large group of actors.

Four days later Armfield said after the first run through of the second act that it was

one of the frustrations that would affect [them] deeply [and that they wouldn't] have time to rework the play [but would have to] bring it up through runs, careful notes and little spot visits.

Having been 'spot visited' twice it therefore remained for this scene to find its focus when the whole play was assembled and run in the fifth week or rehearsal. For now the action for other scenes within the act needed to be 'found.'

---

<sup>42</sup> Simon Callow has echoed this thought, commenting that from an actor's point of view his preferred

director's conduct of rehearsal ... favour[s] ... anarchic high spirits, laughter and improvisation ... For me contained anarchy is the most fruitful. Play should be at the heart of rehearsal as it should be at the heart of performance. So many of the best inventions and the truest impulses have grown out of mad horseplay. (1984: 161)

### 4.3. The 'Accident Scene'

The third 'company' scene was the last scene of the first act (Sewell 1983: 37-38) where Bruce, a steelworker and Allen's brother narrowly escapes from an accident in the steel mill when a channel breaks, sending molten steel across the mill floor. The playwright's directions call for:

*action that is as terrifying and spectacular as possible [and which] depends entirely upon direction and is open to alteration according to the resources possible.*  
(Sewell 1983: 37)

This is the action the designer Stephen Curtis had indicated in the design presentation that the company would 'find' in rehearsal.

On day ten Armfield advised that they needed to set the space up for the scene by having Weaving walk along the back of the stage (parallel to the wall) thereby 'creating a channel.' Russell Kiefel and Steve Rodgers he added would then move the 'table upstage to the channel.' Armfield continued explaining that the scene would start with the same line as in the script: 'the fucking channel's busted' but with more 'people' than just Bruce saying it. He added:

We're trying to find the most dramatic way of starting the scene.

The side door from between the stage and the street would 'open' and through which 'smoke and light would come out to give a sense of an open channel.' The table would play a central role in the scene. Armfield indicated that this was the scene where the table would come loose for the first time from the wall and 'spin around' rather than in the 'train scene' as Curtis had originally envisioned. He continued: 'The table is like a structure that is loose' and while Bruce was trapped on the table the rest of the cast would 'push him around.' A discussion then occurred to clarify what would actually happen in such an accident with Stephen Curtis who was present indicating that the main danger was the flow of 'molten metal on the floor.' Armfield added that the table would become 'the barrier' on which 'one side was safe.'

With Armfield having established the general use of the table in the scene, the company then discussed how the

characters would act and respond to the danger. Ralph Cotterill asked why it was that in the stage directions Doug '*strikes*' Bruce after the latter has survived the accident. Armfield responded that it was like a father disciplining his son for making a potentially fatal error in judgement. He added that 'people should just scatter' and Bruce would be 'aware of the danger.' Jason Clarke, the actor playing Bruce replied that he 'can't move' and which Kiefel reinforced explaining that Bruce would be 'frozen with fear.'

Armfield then directed the rehearsal from discussion to physical action advising the company: 'let's try and just get the shape of it [and] walk through it slowly.' The company members were variously assigned stage action, including disconnecting the table, turning the table, running across the stage and opening and closing the street door. It was a total group effort. Kerry Walker, who had the job of opening the street door, told me that it was typical of the company's work ethic where everyone supported each other and the stage action 'one hundred percent', irrespective of whether they had a major or minor role. Armfield further clarified the role of the table by stating that it was 'like a bridge over a swimming pool' of molten metal where one end had broken. As the scene was then walked through, run at half-pace and run through twice at normal scene Armfield commented that he 'might be wrong' but that he thought Carroll as Doug would 'run in pursuit of the table' which, together with the open door, was the 'main focus.' He also advised Clarke to imagine that he was 'forty feet off the ground' and that the 'point' where the table 'stopped spinning' was where he would 'jump off.'

What emerged was stage action that was extremely exciting and which gave a real sense of danger as the table was vigorously swung around twice by the company, before being stopped to allow Bruce to step down from the table and to safety (see Figure 3.). Like the 'train scene' Armfield had foregrounded the specific use of the table and the roles of the company in moving the table as a way of structuring the scene, thereby fulfilling the playwright's general vision for the scene. What differed was that Armfield had begun the rehearsal of this scene with a clearer idea of how it would work. Although he still spoke of the company and himself as 'we' who were trying to 'find' the dramatic quality of the scene, he had quickly prescribed how all the action would take place, himself. The pace with which this scene was realised was perhaps a reflection of an increased working rhythm gained by day eleven and from an increasing awareness of the amount of work still to be done.

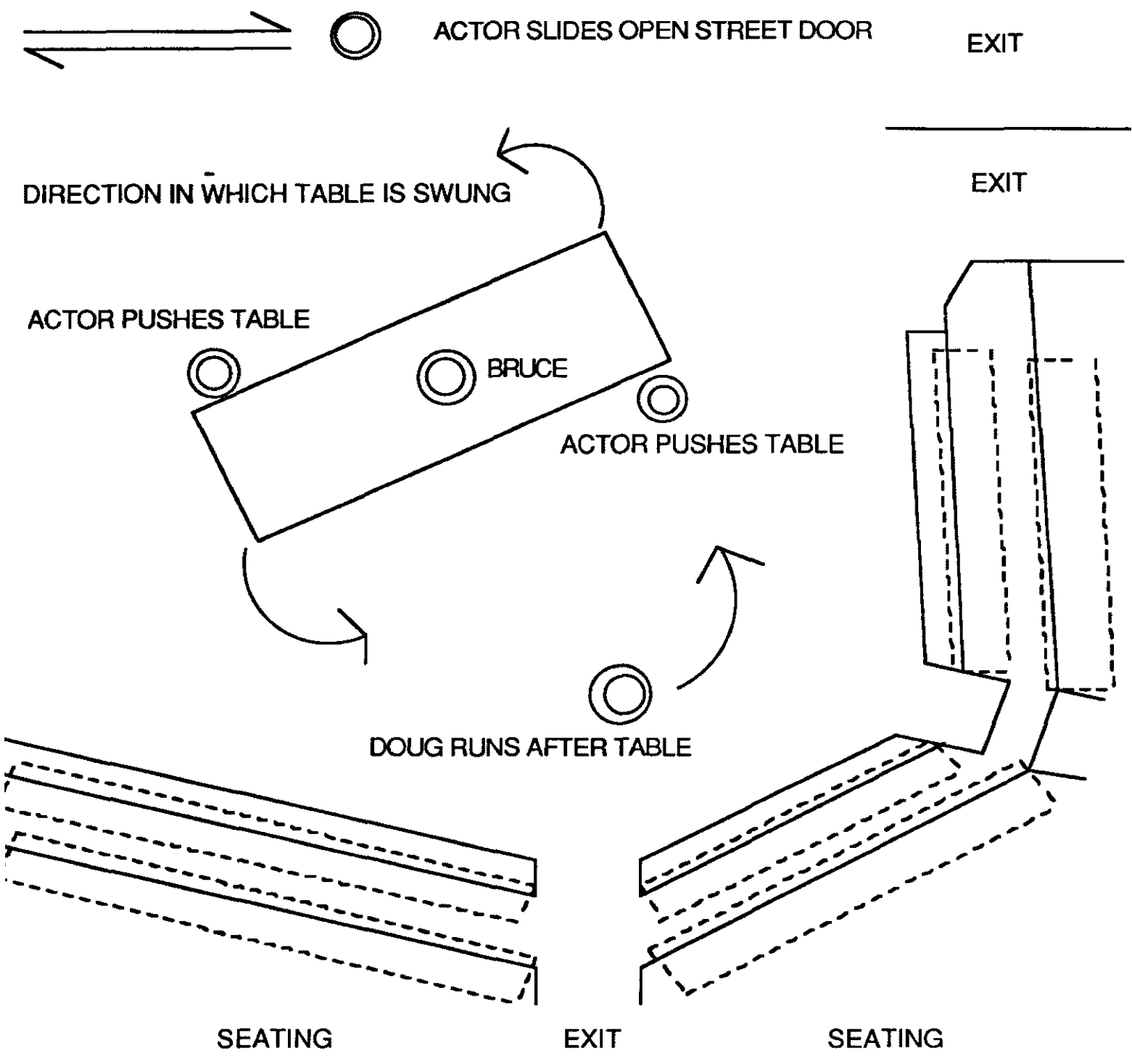

Figure 3. The 'accident scene' (Act 1 Scene 10).

## **5. A FAMILY SCENE IN ACT 2 - A 'DEMOCRATIC FASCIST'**

### **5.1. The 'Barbecue Scene'**

In act two scene seven (Sewell 1983: 56-61) Allen and his wife Louise come to visit Allen's parents, Doug and Eileen Fitzgerald and Allen's brother, Bruce at their country home. Over a barbecue Louise initiates a debate over the forced acquisition of land from the aboriginal owners and the subsequent misuse of this land by the Fitzgerald forbears.

It's worth remembering from the discussion on day one that Bruce was then defined by Armfield as the 'anchor' while a 'number of characters' around him were in a 'paranoid spin.' Further, Sewell with whom Armfield had concurred, had stated that Bruce does initially 'deny' who he is in order to survive living in the 'gentle patriarchy' of his father's house in the first half of the play. Bruce undergoes a major transition in the third act when he joins and works for the union against the wishes of his father, who subsequently forces him to leave home. How Armfield constructed Bruce's path through the play was to direct Jason Clarke to portray him as initially something of a country innocent. This directorial interpretation arguably became central to how, in rehearsal, Armfield concentrated the focus in this scene on Bruce.

At a quarter past five on day three of script work the company read through the scene. Armfield asked how long it was since Frank, Allen and Bruce's brother, 'had been killed in Vietnam?' Weaving suggested 1966. Armfield then noted that Frank was the youngest and Allen the eldest. Peter Carroll commented that it would place Allen in his 'forties.' In much like the general time period given previously for when the play is set and the accompanying blur of the costumes, Armfield argued that: 'we don't have to be too literal regarding age.' Kerry Walker, however, noted that Bruce would be twenty-five. Armfield replied: 'it doesn't matter, he's a symbol' and added 'everyone's playing a symbol.' Walker immediately commented rather wryly: 'including the director.' If Walker had a warm but slightly weary empathy with Armfield as her director, her quick and sardonic wit was never far behind.

Seven days later (day eleven) and immediately prior to the start of the blocking of the scene it is interesting to note what she had to say about her longtime working relationship with Armfield. Walker is an Armfield veteran having worked with him since the Lighthouse days and at the time of this rehearsal, she was also on the Belvoir Board. She addressed Armfield with a tone of resignation:

The first few years I worked with you I tried to fight you then I realised what was best.

In private conversation with me Walker revealed what was 'best' was to be allowed to make mistakes, to question to a certain point, but then to accept Armfield's point of view before moving on. However Armfield's final point of view still might include a blocking move for example proposed by the actors themselves. For Walker what she valued most highly in rehearsal was the 'freedom' for the 'actor ... to try things'; she could initially show 'one option' but could have 'five others' available. However if the director 'killed' that first option she, as an actor would become 'nervous with no possibility to create.' Rehearsal was therefore for Walker an opportunity to explore different ways of performing a scene, a site of genuine experimentation but which depended upon the director's encouragement. The latter, one could surmise was to be nourished by Walker's consistent sardonic witticism in rehearsal. The value of Walker's comic commentary on rehearsal cannot be underestimated in maintaining a playful and gently rebellious atmosphere in the rehearsal room. Cate Blanchett described the ensemble as 'laughing a lot' and 'being in hysterics' as they worked on the play, describing Walker in particular as 'a very funny lady.' Blanchett herself affirmed the value of the comic in facilitating creativity by commenting that by making 'a fool of herself' she was giving herself the 'licence' to do 'whatever' she wanted and to remove any 'inhibitions' about her 'work' (in Stewart 1995: 16). Hugo Weaving in turn commented privately to me that while 'everyone has a time-clock in their heads' and which meant that normally he just 'wanted to get on with things' he was also 'loving the freedom to be able to muck around' for a change.

At the beginning of the scene, the playwright's directions indicate that Eileen enters with plates of food. Armfield suggested that it should be: 'a huge platter of meat, old style.' He then asked: 'how should we do it?' There was a slight pause before Armfield outlined the scene himself:

It would be a nice pattern Kerry [Eileen] if you come to Catherine [Louise], then to Hugo [Allen], while Peter [Doug] has come on at the same time and taken up a position of power at the end of the table while Bruce should sit on the floor (see Figure 4.).

Armfield had begun the blocking of both the 'train' and 'party' scenes in this same way: posing a seemingly open ended question and then answering it himself. Was he really asking for suggestions from the company? Or was he posing a purely rhetorical question? Or a bit of both? Russell Kiefel revealed recently to me that he thought Armfield always 'knew what he wanted' when working on the floor. However that is not to say that Armfield was immune to suggestions from the other actors, as was evident in the blocking of the 'train scene.'

Jason Clarke did indeed have a suggestion to where he thought his character, Bruce, would be placed, indicating 'over by my brother' (Allen) to which Armfield replied: 'not necessarily.' This is in partial contrast to the playwright's directions which state that '*Allen and Bruce are sitting on their haunches ... Doug a little away from the other two*' (Sewell 1983: 56). Kerry Walker supported Clarke stating: 'I think he should be in a much more prominent position.' To which Armfield replied: 'he's very prominent' — 'prominent' one might add in how Armfield had physically isolated Bruce from the other characters and consistent with his view that Bruce's journey through the scene would be thus literally foregrounded. Walker then suggested that she move up towards him (Bruce) as she had to 'give him knives and forks sometime' to which Armfield agreed. Walker thus initially supports her fellow actor, one of the younger newcomers to the ensemble who she perceives as unhappy, by first challenging Armfield on his placing of Clarke. On Armfield's insistence she then accepts his choice but is able to add to the blocking by proposing her own action towards Clarke which Armfield accepts. This would point to a fairly mature relationship between the two, where the director, while maintaining his right to pursue his vision for the play, is still open to an actor's suggestion.

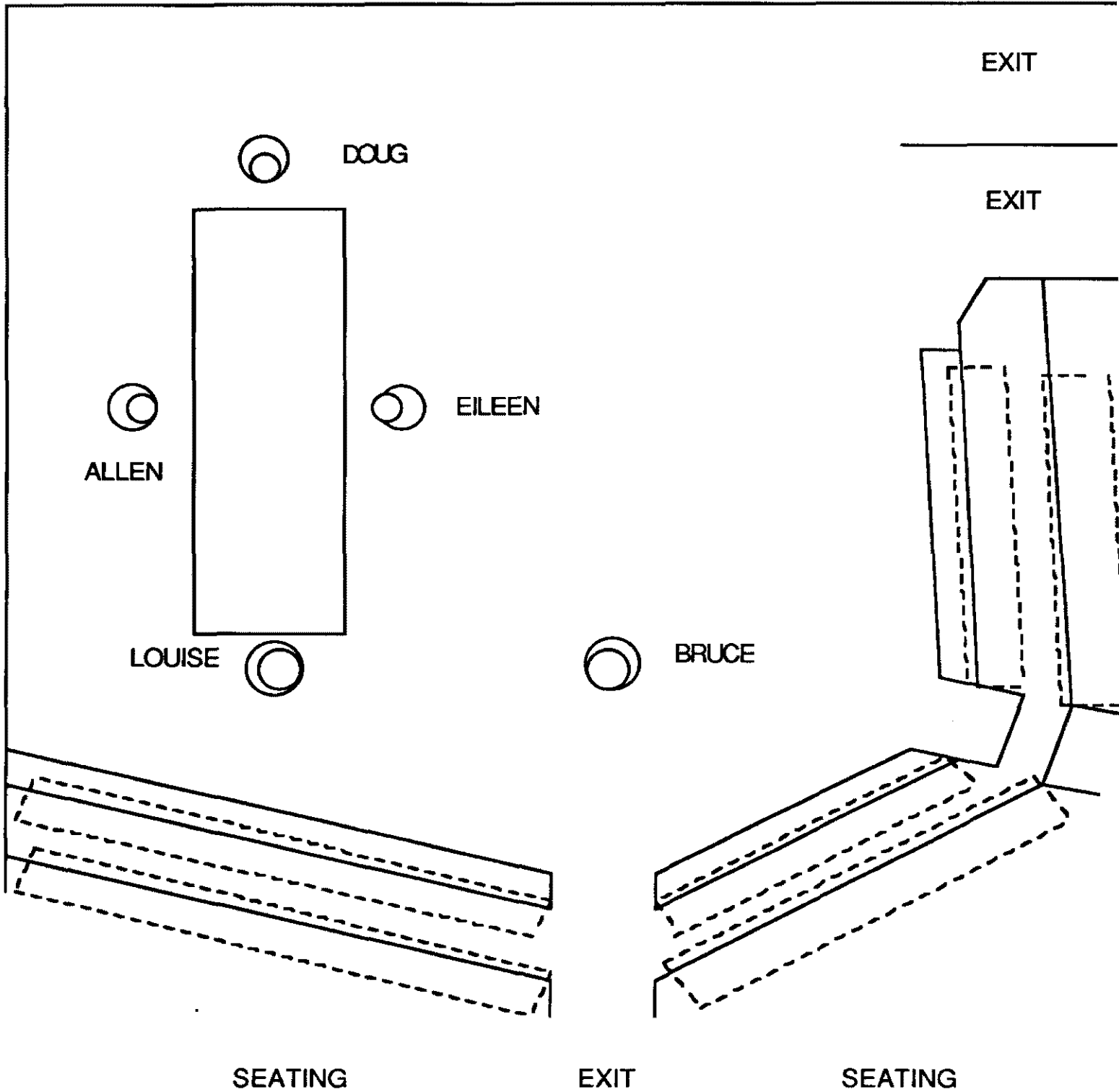

Figure 4. Starting positions for the 'barbecue scene' (Act 2 Scene 7).

Armfield then asked: 'would it be better for the table to be on a diagonal' before moving the table himself to this position (see Figure 5.). Catherine McClements replied: 'it looks 'great' while Walker commented: 'it feels much better.' Armfield added:

I quite like that [it's] naturalistic [and] it feels quite nice [having the] formal separation of men and women ... with no chairs or one chair [only].

Clarke had now moved back towards the table where he had originally wanted to be, 'by my brother' which Armfield seemed to accept commenting: 'it's nice with you down there [too].' Hugo Weaving asked if the table would be swung at the beginning of the scene or 'prior' to it? Armfield replied: 'it would be quite nice if Jason [Clarke] walks on and turns the table.' The start of the scene was run and Armfield then directed Walker to 'lead the change' of scene, that is to enter first, while he asked Weaving to remain where he was at the end of the previous scene. Armfield then asked: 'I wonder if it's too organised?' A question that was not unlike the earlier 'how should we do it' in that it was arguably directed at both himself and the company. This question is also perhaps representative of Armfield's own consistent search for the right 'option' and the ability to withstand the pressure of limited rehearsal time and to accept the comfort of a perceived easy solution. After another run through of the beginning of the scene Armfield echoed this initial unease, stating 'I fear it's a bit boring' and added:

We can see how it goes and then change it when you're used to it.

There was immediate laughter from the actors as they recognised what is often a director's prerogative and a potential annoyance to an actor when set blocking is changed by the former. The importance of self-reflective laughter in aiding the working through of this scene can not be overstated as a means to exploring the starting positions for the actors. The laughter already alluded to by Walker, Blanchett and Weaving was by now an integral part of the atmosphere which Armfield continuously encouraged in the rehearsal room.

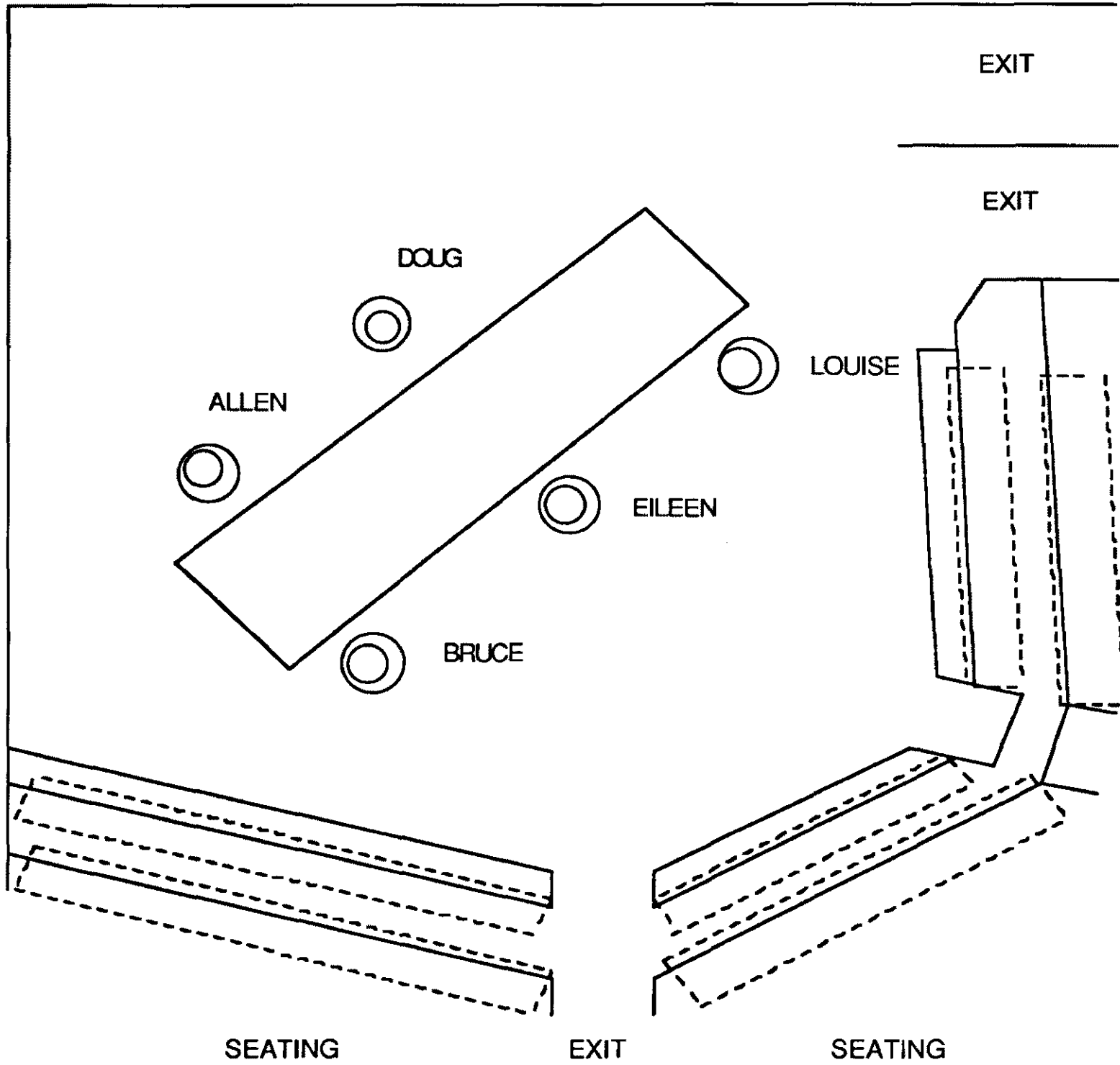

Figure 5. Revised starting positions for the 'barbecue scene' (Act 2 Scene 7).

Armfield then directed a couple of small changes, advising Walker that her reaction to seeing a 'shooting star ... should be quite small' and in particular asking Clarke to drop the 'h' from 'nuthouse.' This aural blocking direction to Clarke to structure a colloquial argot would seem consistent in establishing an initial innocent and country-like voice for Bruce. Armfield then advised the cast that he was 'putting' them 'on notice' and that 'these table days were numbered'; that is, the present positioning of the table was likely to change. As they continued working through the scene Armfield finally relented, stating:

This is really boring. I think we'll have two chairs for the ladies and the table against the wall and across.

A big space here is good. [downstage]

He then asked Clarke:

What's it like if you've got your back against the table end?

Clarke replied 'Fine' but did not move. Armfield in turn, insisted asking 'can I see it?' After Clarke tried this new positioning Armfield then noted that it was 'better' if he was 'further down', as he had initially placed him (though more towards stage right) and even more so now to fill the newly created 'big space', downstage. Walker concurred with the changes stating 'this feels better' and Armfield in turn noted 'this feels like a much more meaningful set of relationships' (see Figure 6.). Armfield then showed Clarke the exact orientation that he wanted him on the floor saying as he demonstrated:

Facing front is too conscious of the audience. It's better having your back slightly to the audience

However Armfield, seemingly forever looking for the best option, asked: 'how can we improve this?' Peter Carroll in turn immediately sought to clarify how his character Doug handles the central debate in the scene:

I don't know how polite I am to Louise. We all think she's a bit bad and he's [Allen] not pulling her in line.

Armfield: You would notice it. Her aggression.

Belvoir Street Upstairs Theatre Scale Approx.1:80.

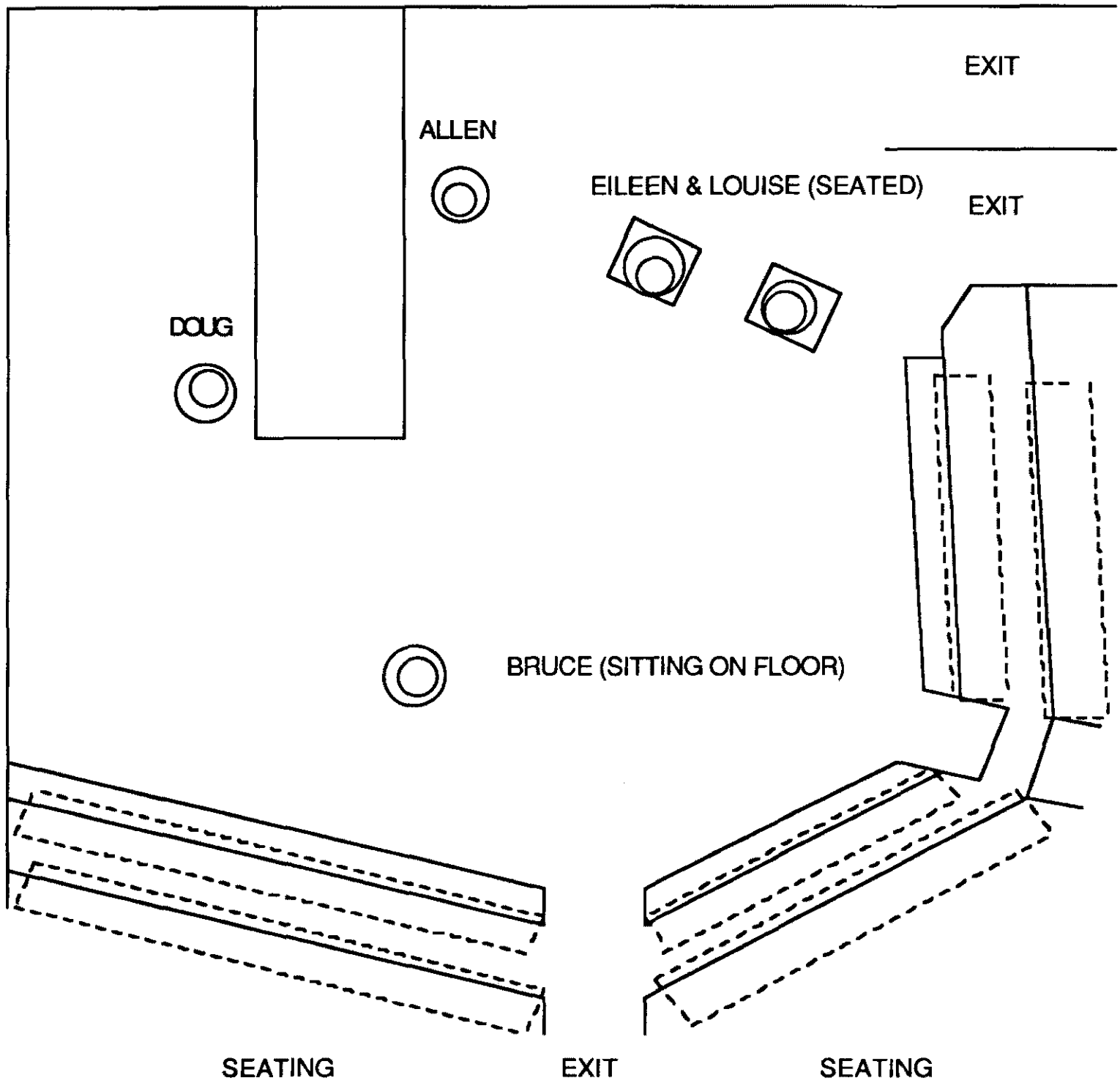

Figure 6. Final starting positions for the 'barbecue scene' (Act 2 Scene 7).

Carroll: The attack is against me because I said we owned land out there.

McClements: The most I feel is against you.

Armfield: Bruce is defusing a fight between Louise and Doug.

McClements: Bruce is the easiest target.

Armfield: Bruce is defending the father. Bruce is annoyed at the way Louise attacks white farmers.

Clarke: I don't think Bruce is worried by it.

Armfield: It's Bruce's inquisitiveness ...

McClements: ... that keeps the scene running.

Armfield: It fuels the next scene.

Clarke: He's working towards having an open discussion.

Armfield: Eileen and Allen wish it would be hosed down with garden and weather [small talk] and Bruce is quite interested and engaged by it.

McClements: Part of Louise's anger is no-one is taking it up. Her anger is more at Allen

Armfield: Her burning hate is put onto Bruce.

Carroll: Alright I'll try and be charming this time.

Within the context of the establishment by Armfield of Bruce as the 'anchor' within the play it would seem clear that Armfield has directed the playing of Louise's 'anger' for Allen, away from Doug and onto Bruce. As they worked through the scene Armfield advised Clarke that it was 'too sentimental touching mum.' Clarke asked 'why not' and Armfield replied 'because it's not a touching family.' Hugo Weaving confirmed Armfield's view commenting: 'we're dysfunctional mate.'

Walker then suggested that Clarke 'just squirt me' with tomato sauce to which Armfield replied: 'that's a good idea. Squirt everybody with sauce.' Clarke was reluctant to do this to Louise (Catherine McClements) and Armfield asked: 'why not with

Louise?' Clarke replied: 'cause she had a go at me.' Armfield countered: 'I think you should do her first.' In fact the 'squirting' of the sauce was right at the start of the scene, in any case before the central debate began. After running through the 'squirting' of tomato sauce twice Armfield suggested to Walker to: 'use your fork to point towards Doug on [the line] "Doug's father"' while encouraging Weaving's 'Aussie drawl' and then rhetorically asked Clarke:

Is it worth playing that [line: 'Diary? Geez.'] across to your mum?

This is Bruce's response to Allen's comment that he'll have to check his diary in regards to catching up with Bruce on the weekend. By directing Bruce's comment to Eileen, his mother, Armfield was able to aurally give shape to Bruce's naive admiration for his brother and he commented after subsequently running it twice in rehearsal that it was 'good.'

Armfield then asked McClements to also point her fork (to Eileen) on the line 'now there's a year' (a reference to 1848 the date of the publication of *The Manifesto* by Karl Marx) mirroring his previous direction to Walker. He asked Clarke in reference to a forbear missing out on a gold rush to add a 'hey!' before the line 'maybe he got lost' and 'piss himself' laughing. Armfield also asked Walker to wink at Louise where Eileen comments that the forbear in question was probably transported for being a 'fighting Irishman.' Walker commented in response to the comic business that Armfield had given her and Clarke that they were becoming 'the really funny Fitzgeralds.'

Armfield responded that:

It's nice having a general level of mirth that is cut by the Aboriginal line.<sup>43</sup>

Armfield also asked Clarke to give 'a little huh' after Louise asks about the 'Aboriginals.' Armfield was evidently directing the build-up to the central debate through the layering of at times infinitesimal detail to create this 'general level of mirth.'

---

<sup>43</sup> The line in question is after Louise asks 'what happened to the Aboriginals who previously lived on the Fitzgerald land?' to which Bruce in turn asks the question 'there weren't any out there, were there Dad?' There is a slight pause before Doug replies 'I suppose they killed them' (Sewell 1983: 58).

However there seemed to be a fundamental difference between Armfield's vision of the Bruce character and the way that Clarke wanted to play Bruce. Clarke asked if he should 'be more snaky', which would seem at odds with Armfield's direction so far. Armfield advised him, gently that he was 'doing really well but to [in fact] cut back with the last line.' The last line was Bruce's rationale for the acquisition of the land by his forefathers:

They [The Aboriginals] hadn't done anything with it!

Armfield also advised Clarke that 'the rising inflection on [the line] "there weren't any out there, were there, Dad?" [...] helps your innocence.' Clarke replied in turn that 'It makes me look stupid.' Armfield countered with: 'no it doesn't. More ignorant.' Hugo Weaving concurred with Armfield commenting that it made Bruce appear 'more youthful.'

Whether Clarke had effectively taken on this sense of innocence that Armfield wanted him to reveal in Bruce was revealed in the first run through of the second act five days later on day sixteen. I noted at the time that Clarke did indeed give a convincing tone of shyness to Bruce. However there was a sense of unease within the cast that the debate within the scene was now being underplayed. In the discussion following the run of the act Catherine McClements stated 'I think the fight with Bruce is not strong enough.' Armfield replied:

I think [the line] 'what happened to Aboriginals' is directed through sausage and not directed to anyone.

McClements commented 'that's good.' This would seem to further shift Louise's 'hate' away from Doug while allowing Bruce to take it full on. The discussion continued:

Carroll: Maybe the whole thing grinds to a halt and ...

Armfield: ... and Allen goes faster. [i.e. eats quicker]

Stephen Sewell then commented to Carroll that:

There is resistance that you don't want to offend Allen's wife. [and] Voices don't have to be raised for there to be a disturbance.

Armfield then shifted the discussion markedly:

I was going to suggest we lose [the line 'oh look there's a] shooting star.'

McClements: Oh no!

Walker: I've never liked it. I made it work.

Armfield: If you don't like it it wouldn't work.

Walker: Get fucked. I made it work.  
Can we have 'shooting star?'

Armfield: We'll look at it.  
I hope I didn't undercut you.

Walker: You have never undercut me.  
Where there's no sense there's no faking. [Laughs]

Armfield ended the discussion commenting to Walker:

As your director I wouldn't be doing my job if I didn't say it.

It is intriguing to note that once Armfield had apologised to Walker for suggesting that she couldn't make a line work that she didn't like she freely admitted that the line wasn't worth keeping anyway, and subsequently agreed with Armfield that she indeed couldn't fake it.

The question of whether the 'fight' within the scene was 'strong' enough pointed to whether Armfield wanted to externalise or internalise the tension within the scene. His direction thus far to the cast had been to underplay the debate by directing Bruce to 'defuse' the fight between Doug and Louise, and for Louise to direct a provocative question through 'sausage,' rather than at anyone in particular. It was an approach that had been confirmed by Sewell's comment that 'raised voices' weren't necessarily needed to create a 'disturbance.' It was a question that would be answered more clearly when the scene was placed into perspective and the play was run as a whole.

The process of working through the scene had seen Armfield try out several different starting positions for the actors, one of whom (Kerry Walker) was also able to suggest a move that Armfield accepted: giving knives and forks to Jason Clarke.

Walker also suggested an action for Clarke: 'squirting everyone' with tomato sauce which Armfield accepted and directed Clarke to enact. However the greater flow of ideas for physical and vocal intonation went from director to actor. Armfield concentrated on particular physical and verbal nuances with the cast in order to subtly accentuate the progression within the scene from early 'mirth' to the tense aboriginal debate. They were small but distinctive moments in defining an actor's performance that reflect Ann Bogart's 'acts of violence' as the director gives the actor specific fixed action(s) that they embody.

Susan Letzler Cole in analysing a director's<sup>44</sup> approach to Chekhov's the *Cherry Orchard* has noted that:

The addition of a simple prop ... is often more than a simple addition to a scene. It can be an enabling and determining factor, especially in rehearsing a play which inscribes its props in its language. (1992: 16).

In the 'barbecue scene' in the *Blind Giant*, Armfield had fully exploited the use of the props 'inscribed' in the text. The ways in which Armfield had directed the actors to employ these props in the scene had created an outer physical structure for a partially hidden inner psychological structure — an external world of action that represented an internal world of 'denial' identified on day one of rehearsal.<sup>45</sup> The 'machine-like' use of the tomato sauce bottle set up a regular domestic rhythm that masked the inner family tension at being together again, the directing of verbal text into 'sausage' defused a family fight and the use of forks to physically direct the dialogue gave a literally 'pointed,' comic commentary to a family with a deep sense of malaise. Armfield had even used the action of eating to mask the family's unhappiness, for example directing Weaving to 'speed up' eating to cover Allen's embarrassment at his wife's outburst in the scene.

Two days later (day thirteen), when working through the this scene again, an exchange between Armfield and the *Sydney Morning Herald* photographer Paul Jones suddenly forced Armfield to define himself, as a director. Armfield told Jones to 'get a shot of the two girls' (Walker and McClements) and Jones replied that Armfield was 'just a fascist' who 'wants everybody to do what

---

<sup>44</sup> The director was Elinor Renfield.

<sup>45</sup> Stanislavski noted that for 'every physical action' that there was 'an inner psychological action' which gave 'rise to it' and that 'the unity between these two' was 'organic action on the stage' (in Benedetti 1985: 130).

you want.' Armfield pulled a mock indignant face while Hugo Weaving countered that Armfield was a 'democratic fascist.' Armfield himself reflected that Louis Nowra had called him a 'fascist for detail.' McClements then playfully commented that he was however, 'still a fascist.' Armfield responded that if that was the case he would give them 'as much direction' as a certain other director had recently given his cast and they'd see how they would 'like that!' Then as they worked through the scene and after Armfield had advised McClements that she 'should move after' a particular word he suddenly turned and addressed Jones:

That's what a director's meant to do, Paul. To give direction. It's a job. It's not what you want to do.

Armfield's adoption of Nowra's description reflects the detail that he instructs the actors to replicate. It also underpins Armfield's sense of duty as a director that, notwithstanding his apology for directing, he sees it as his responsibility to gently but firmly advise the actors where to move and at what point, how to use particular props and how to say particular words. This seemingly gentle autocracy is countered by Armfield both giving the actors a chance to first run the play and individual scenes by themselves and then to offer specific actions of their own in the course of blocking a scene. Weaving's description of Armfield as 'democratic fascist' may well then be an apt indicator of Armfield's working methodology. That is to say, that within a given structure or framework that Armfield creates there is some room for both himself and the ensemble to improvise and explore before he specifically defines what stage action will take place. This improvisation is guided by a series of 'how' questions that Armfield poses to both himself and the cast. These questions are arguably not entirely rhetorical as Armfield does allow some debate, and does occasionally adopt suggestions that come from the actors themselves.

## 6. CONFRONTATION BY TWO

### 6.1. Allen and Wells Confrontation

In this scene which opens the third and final act of the play (Sewell 1983: 81-86) Allen Fitzgerald meets with Michael Wells on the latter's invitation. Wells proposes a 'deal' with Allen, who rejects this claiming he'll 'take the lot', including Well's position as Social Democrat Secretary. This scene represents a turning point in the power struggle between the two characters. Whereas Wells had publicly taunted Allen in the 'party scene' in the first act, Allen is now able to challenge Wells openly for the latter's position which he subsequently attains late in this act.

Armfield planted quite early in rehearsal the seed of how the actor Russell Kiefel would visibly characterise Michael Wells, the Party Secretary. On day four in the midst of script discussion Armfield mentioned to Kiefel that he would have a 'Richo bouffe', that is to say, his hairstyle would resemble that of the former Federal Labor politician Graham Richardson; a figure that Armfield would return to again in the course of rehearsal as a character reference point for Kiefel.

The following day, day five, the first scene from act three was read and discussed in detail. Armfield commented that for him if the first act was set on 'earth', the second was in 'purgatory', while the third was in 'hell.' Indeed, after Allen has taken Well's position from him (on false charges of drug related corruption in scene twenty-six of the third act) Wells exclaims to Allen that he hopes he'll 'rot in hell!' Armfield's sense of metaphorical place for the third act would seem to literally concur with Sewell's text. The reading began but was soon interrupted by Armfield who asked aloud what was meant by the 'Alternative Economic Strategy' proposed by Allen. Weaving replied that it was a 'Marxist plan to run the Steelworks.' Armfield then clarified the position of Wells in this scene, saying that he was 'on the back foot', having been outmanoeuvred by Sir Leslie Harris, the Director of Austeel, who had 'come good with his bluff' to sack steel workers in the absence of continued government subsidy. Consequently the unions were now in a 'position' where they would have to consider voting 'Wells out of the [party] executive.'

Peter Carroll was, however, 'confused' about what was 'at stake dramatically,' the 'order of events' and what 'shoves the plot along.' He concluded that he found 'those details in plotting difficult' to understand and by inference so might the 'audience.' Armfield responded that 'dramatically' Allen and Wells were 'both bound together' and that Allen's upward 'trajectory' to power was 'fascinating.' Jason Clarke and Hugo Weaving noted 'Wells' [alleged] corruption with drugs' that 'brings him down' while Armfield commented that Allen on the other hand wasn't 'destroyed' and would 'go on to become PM.' Russell Kiefel concluded that the 'deal with [the criminal] Charlie Palmer' made by Allen had 'fucked up Wells' and even if it came out it wouldn't 'hurt' Allen as he was now 'morally empty.'<sup>46</sup>

Having clarified the broad political background to the scene and the 'trajectories' of the two characters in question in the third act, the reading continued. Sewell then asked why was it that 'people' in the play 'sacrificed themselves?' Kiefel replied that it was because 'the ends justified the means' and that it was 'what the play [was] about.' Armfield both concurred and differed slightly with Kiefel, commenting that there was 'no end, just means.' This is consistent with Armfield's previously stated intention (on the first day of rehearsal) of wanting to show how power and position are attained through the 'fights' in the play; in this instance Allen's rise to Party Secretary, the 'means' of which were 'fascinating' for Armfield. Sewell concluded that in Wells' case it was an 'interesting confusion' to consider that he may well be 'both morally and politically corrupt but not necessarily criminally corrupt.' And that while he was 'morally corrupt, he could [still] have a great career.' A statement that upon reflection is indicative of Sewell's general indictment of the Australian political system represented in the play.

Two weeks later on day seventeen Armfield, Weaving and Kiefel returned to block the scene. While Armfield and Kiefel waited for Weaving to arrive Armfield made an illuminating comment to Kiefel that it was 'little things like sniffs and chewing gum that marked his [Wells] personality.' These were actions that Armfield had already directed Kiefel to enact in previous scenes and which were certainly a guide to how Armfield was building Wells, Kiefel's character. It was comparable to the path he had taken with Jason Clarke's Bruce in

---

<sup>46</sup> The deal in question was that Allen agreed to drop both party and criminal investigations of the heroin-trafficking and gun-running Charlie Parker in return for the non-expulsion of party secretaries (accused of 'stacking' their branches) from the executive.

that small personal details were prominent in constructing character signatures. Keifel had also created his own signature action, that of running his fingers along the table as he walked beside it — an action that was comic by its smallness and preciseness when counterpointed against his general slow and powerful body movement.

It is interesting to note that the daily working hours had increased successively over the first three weeks of rehearsal. In the first week the company had begun work at 10:00 A.M. and finished at 6:00 P.M. while in the second week they had started an hour earlier at 9.00 A.M. In this, the third week, rehearsals were now scheduled to finish much later than they had been: ranging from 6:00 P.M. to 10:00 P.M. (See Appendix 11.2). The pressure of a lost week in rehearsal, a third act to be blocked and an approaching performance date had impacted considerably on the rehearsal schedule. If there was a sense of concern that time was running out it certainly wasn't evident in Armfield who remained as calm and relaxed as usual. The director who, as Peter Brook has noted, often comes to rehearsal with the weight of not only the production on their shoulders but the fortune of a theatre career and/or company as well, still has the responsibility of enthusing the cast with a lightness and sense of play as this is what will be reflected in performance (1968: 22 & 117). That Armfield was still able to maintain a sense of fun in rehearsal in spite of the pressure of limited rehearsal time was reflected when Weaving arrived and Armfield allowed the two actors to read through the scene and momentarily turn it into a gangster movie as they camped up the lines 'numbers' and 'what's the deal?'

However, with the reading completed, Kiefel commented that he thought it was 'a cunt of a scene.' Armfield replied that it wasn't 'a cunt of a scene' but in fact 'a good un.' Armfield then asked 'what are the surprises in the scene' thereby deflecting Kiefel's seemingly negative response to the scene. Weaving responded that for Allen it was the revelation that Charlie Palmer had Graham White, his drug running partner, murdered, while Kiefel thought that for Wells it was the accusation that he was involved in drug pushing through a company called Milton Imports. Armfield replied that the latter accusation is a fabrication and is 'rubbish' to Wells' ears. Weaving however commented that it was still 'surprise rubbish.' Weaving also added that he thought that the 'deal' that Wells proposes to Allen got 'lost' in the scene. Kiefel immediately echoed this thought stating that he thought it was 'such a sprawling scene.' Armfield countered saying that he thought the deal sat 'pretty strongly' and

asked Kiefel to clarify why Wells wanted to make this deal with Allen. Kiefel responded:

He's [Allen's] moving towards my position. He [Wells] wants to stay being State Secretary. Allen's getting close to getting the numbers to call him.

Armfield: Yep.

Kiefel: I sold Palmer down the river. I've taken on Harris [the steel capitalist] which has shifted power towards Allen and the unions. My judgement has gone astray.

Having directed the actors to clarify in their own words the 'surprises' and what was at stake in the scene, Armfield then began to physically set up the scene. As he pushed the table onto a diagonal he explained:

I had the image of Wells sitting in his office looking at the view. It's late at night and Allen comes in behind him.

'Chairs?' asked Kiefel to which Armfield responded affirmatively. After setting two chairs along the table, facing downstage Armfield sat in one of them, himself (see Figure 7.). He then rose and advised Kiefel that if he was 'there to start with and looking anxious' it would set-up the scene. Kiefel subsequently sat in the same chair while Armfield asked him if he liked the 'feel of that?' Kiefel responded positively and Armfield then asked the same question of Weaving. Weaving sat in the other chair and himself asked what it would be like if Kiefel's chair was further downstage. He then placed Kiefel's chair downstage and moved the table further upstage, himself (see Figure 8.). Kiefel suggested that 'they could fight over one chair.' Armfield agreed and moved off Weaving's chair while proclaiming: 'winner takes all!' Weaving then moved around to the upstage side of the table (see Figure 9.). Armfield asked 'Kazz' Rodgers the stage manager what she thought and she responded that she liked the 'table on the diagonal.' The pathway to finding the starting positions had thus been framed by a series of questions, of 'what ifs' from both Armfield and the actors that enabled various possibilities to be tried and then replaced before arriving at an agreed option.

A run of the scene was then begun, with Kiefel sitting in the one remaining chair, downstage and facing the audience with

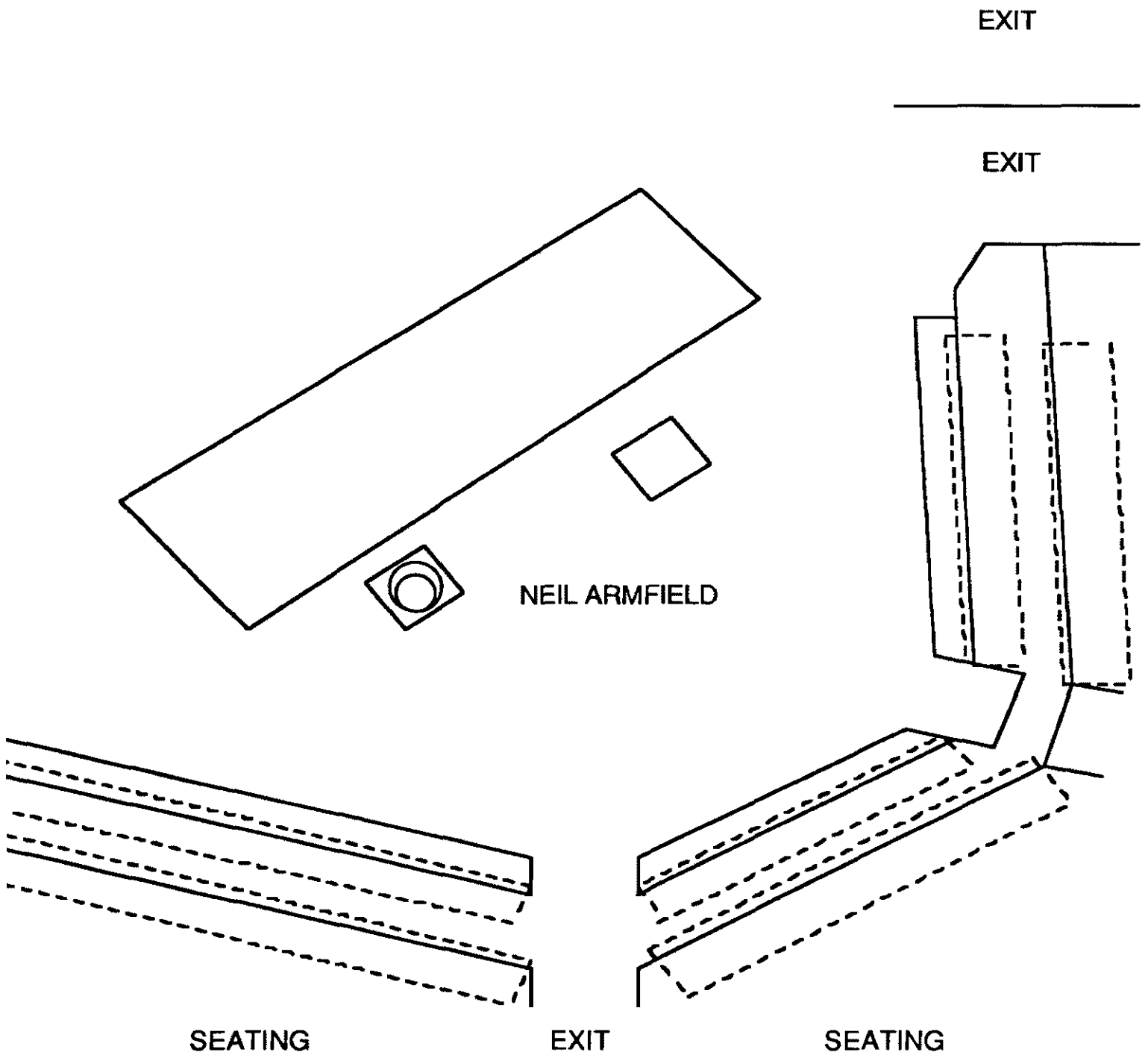

Figure 7. Neil Armfield demonstrates the starting positions for act three scene one:

I had the image of Wells sitting in his office looking at the view. It's late at night and Allen comes in behind him.

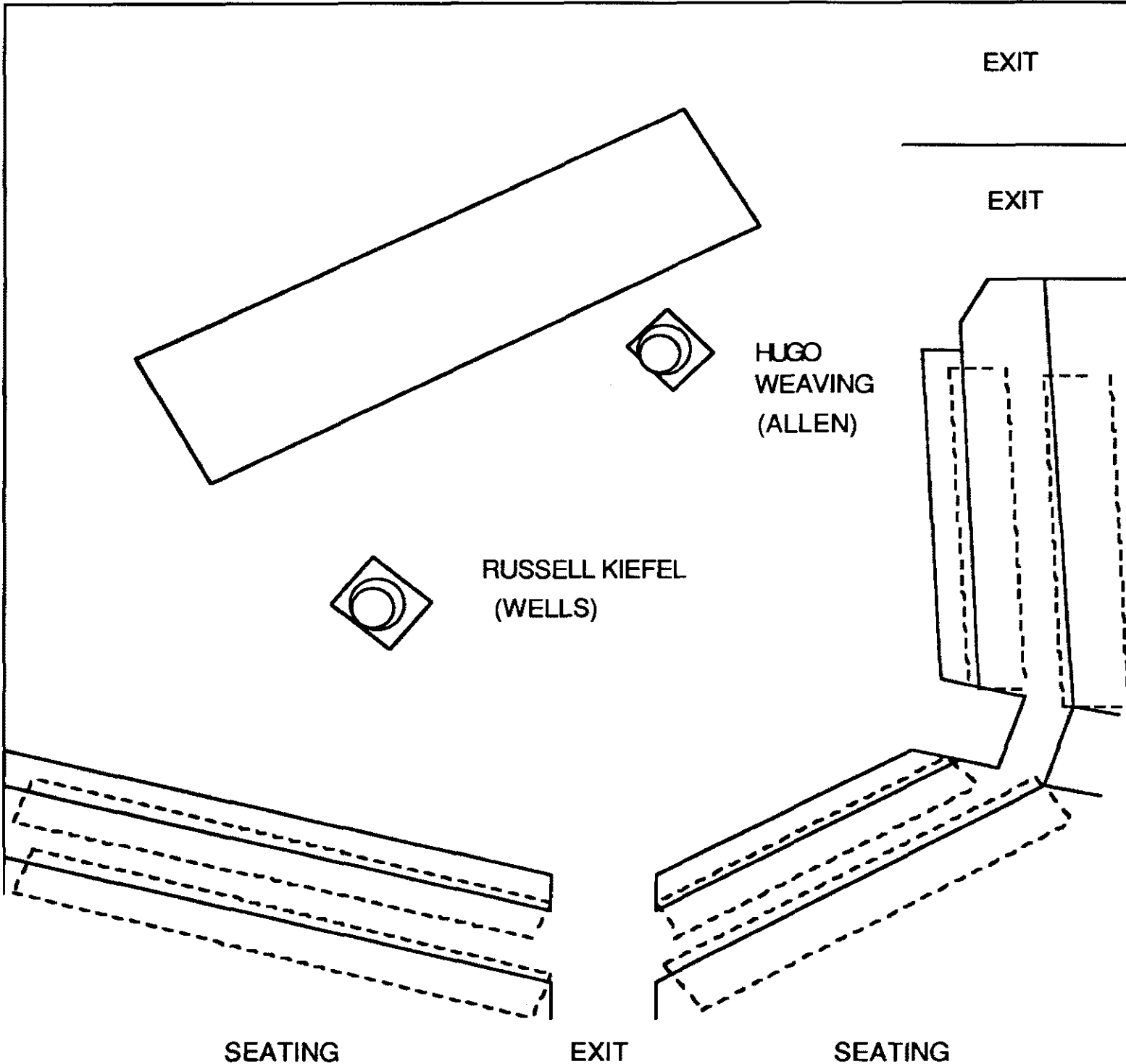

Figure 8. Hugo Weaving changes the starting positions for act three scene one:

Armfield: What do you think Hugo?

Weaving: What if that one [chair] is further down? [He moves Kiefel's chair downstage and his own chair and the table upstage]

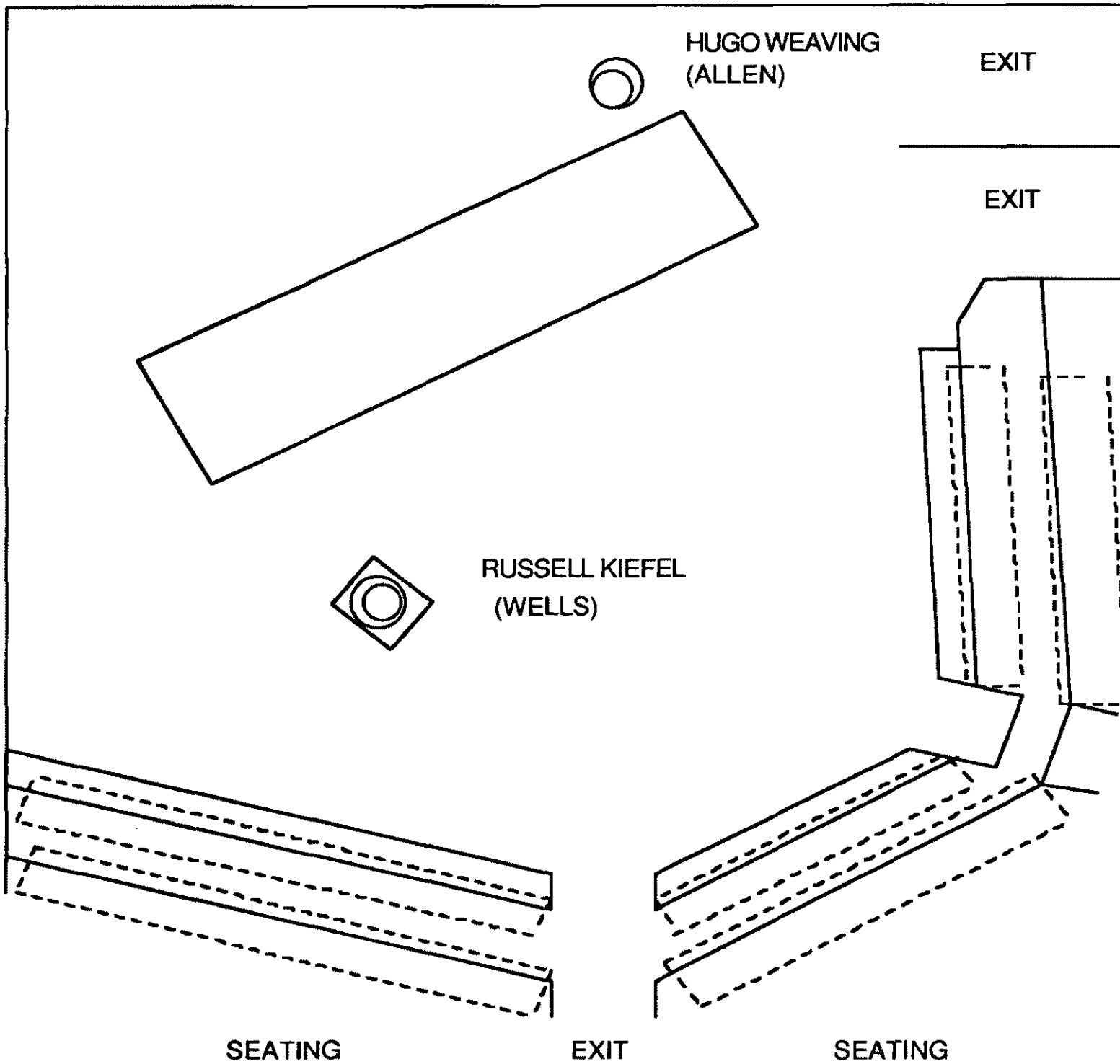

Figure 9. The blocking changes again (Act 3 Scene 1).  
Armfield acts upon a suggestion from Kiefel:  
  
Kiefel: They could fight over one chair.  
  
Armfield: [Removes Allen's chair] Winner takes all!

Weaving then entering and standing upstage. A half a page into the five and half a page scene Armfield interrupted, advising Kiefel to laugh at Allen after he says: 'The first thing we're going to do is to democratise the party.' He then asked how 'it was feeling up there?' He continued momentarily suggesting that the other way they could do the scene was with Kiefel behind the table, like 'a lonely man in power', before abandoning this idea. Kiefel in turn asked if it seemed 'alright' that he remained in the chair? That is to say, whether he should move or stay still. Armfield responded non-committally, but then wondered aloud whether what they had set up was 'more of the mood of the next scene, when Wells is physically shrunken' having lost power. The run continued with Armfield suggesting that Weaving in fact sit in the one remaining chair. Kiefel subsequently stood immediately in front of the table. A few lines later however, Armfield commented that he thought the scene was getting 'stuck' on the diagonal, that it was 'wrong' for Weaving to sit in the chair and that he should enter from downstage. Weaving tried this entry and then the company broke for a tea break.

Immediately after the break Armfield advised that he thought they 'should go for the image' that would 'empower' Wells, by placing him 'behind the table', an idea which he had previously suggested and rejected. He directed Kiefel to 'stand up ... look out this way' (towards the audience) and to put his 'hands on the table' (see Figure 10.). As they then continued to run the scene, Armfield commented that it was 'better.' He also added that it would be 'better' still if Kiefel walked out of the 'shadows' and along the upstage side of the table and Armfield immediately demonstrated this. Kiefel then tried this walk himself, however Armfield noted that it wasn't as 'good as just being there.'

As the scene progressed Kiefel was still unsure of whether to move or stay still. He suddenly attempted to move away from this new positioning. The following discussion occurred:

Armfield: Russell

Kiefel: Stay there?

Armfield: He's stuck — threatened.

Weaving: Like he's [Allen] getting to him.

Armfield: Walk with him, if you want to move.

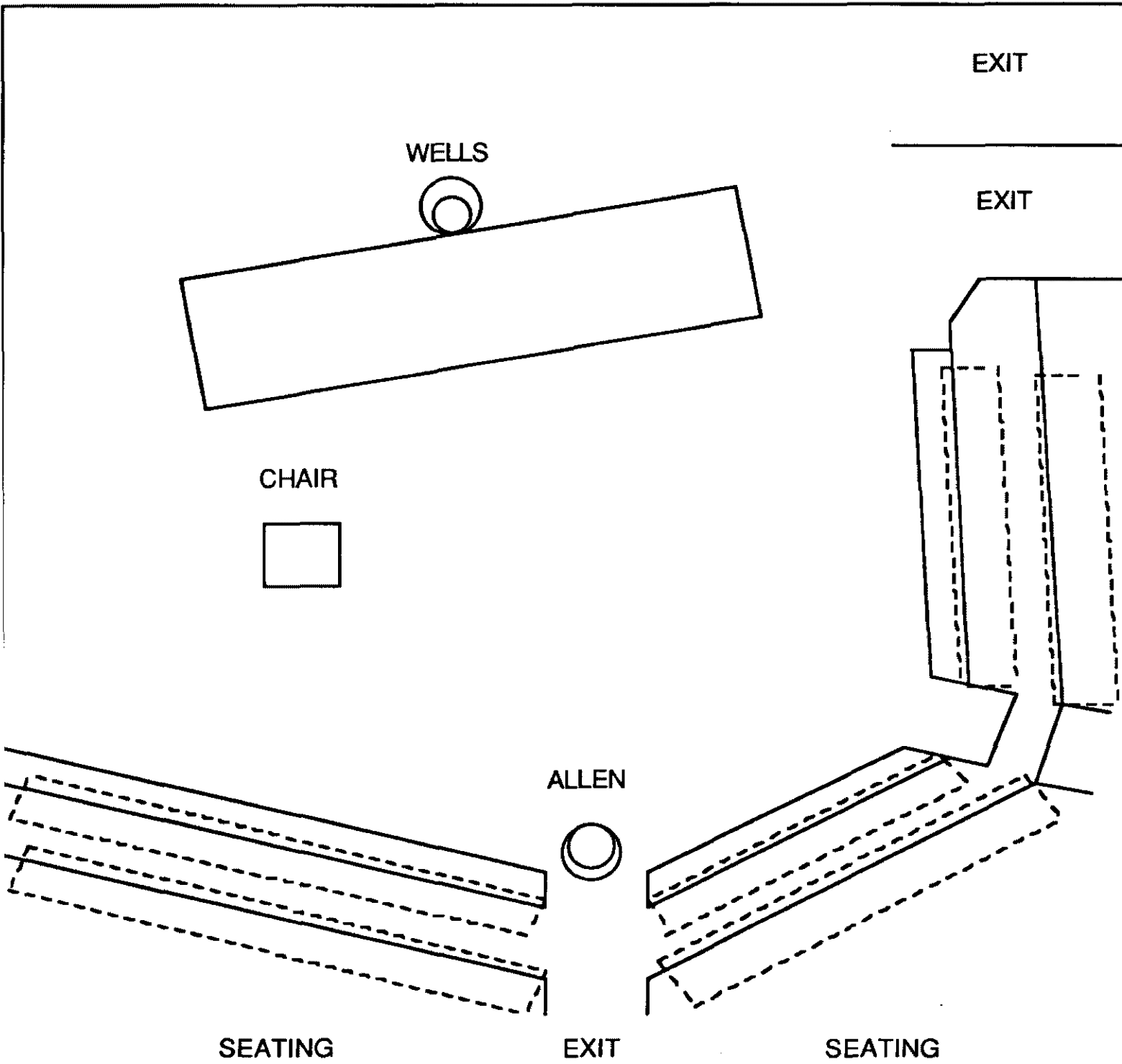

Figure 10. The final blocked starting position for act three scene one.

Armfield: ... I still think you should stay back there. You're feeling trapped.

Kiefel: I'm just presenting alternatives.

Having confined Kiefel to staying behind the table, Armfield then turned the chair forty-five degrees, parallel to the table. Weaving sat in the chair. Armfield advised him that he could sit there earlier when 'Russell starts to talk about the deal' while the 'presentation of the deal' was when Kiefel could in fact 'come around the table ... and come right down to him [Allen].' However in the subsequent run Armfield commented that the 'move down was not so good.' Kiefel suggested that he stay 'back' to which Armfield agreed and then added 'you could move down slowly.' Weaving commented that it was like 'a game of chess' and in respect to the deliberation over Kiefel's moves it was a fair analogy.

The run continued and Armfield commented that if Kiefel didn't move it would be 'more powerful and effective' if he just 'stood there and took it.' However moments later he contradicted this directing Kiefel to 'walk this way and have a little laugh' after Allen proclaims he's 'going to take the lot.' Kiefel responded asking: 'So you want me to move now?' Armfield replied somewhat tersely: 'Yes thanks for pointing that out.' Kiefel however quickly eased any tension by adding that he thought Armfield was 'so fiddly, so creative that it was wonderful.' The run continued and at the time I noted that the corresponding move and laugh by Kiefel after the above line 'worked very well.' Armfield commented that he thought Kiefel should either 'sit' on the table or be 'picking [his] teeth with floss.' Kiefel replied that he preferred the 'floss' idea and proclaimed jokingly that it was 'another first for Belvoir!' It led to a series of 'floss' jokes with Weaving and Kiefel renaming Wells, 'Flossy Wells' amongst other names. Armfield commented that it 'could be quite amusing doing the floss' when Wells states that: 'It was a fucking cop' who killed Graham White. Armfield also added that Kiefel 'could polish his shoes with his legs.' Kiefel replied that: 'gee he's busy' — a comment that echoed Kerry Walker's response to Armfield's detailed direction in the family scene in act two.

Armfield then asked Kiefel if he wanted to replace the line 'you think you know about Palmer' with 'you reckon you know about Palmer.' He then directed Kiefel to make it more 'cavalier.' Kiefel said the line taking Armfield's direction literally, at which Armfield laughed and added:

He's [referring to Graham Richardson] a real sleaze bag.  
Maybe it makes it better if he [Wells] is more nasal?

Kiefel then gave a literal rendition of a heavily nasally intoned voice. Armfield laughed again and added:

Richo [Graham Richardson] has all those prostitutes; it's all laid on. That's a good voice, I reckon.

Graham Richardson thus became not only a visual reference point but an aural one, upon which Armfield was modelling Kiefel's character. The run continued before Armfield commented that there wasn't 'a sense of locating the tape' that was recording the conversation. He then directed Weaving to have a 'slight pause and look under the table for the tape recorder' once Wells reveals that their conversation is being taped. He also added:

I wonder if you [Weaving] should say the drug thing [when Allen accuses Wells of 'drug pushing'] down into the tape?

Kiefel responded with 'great!' and Weaving with 'yeah!' Finally nearly three hours after the rehearsal had begun they reached the end of the scene. Kiefel then suddenly suggested that he had 'imagined starting with a whisky.' Armfield replied that he 'didn't mind' the idea and that Kiefel would need a 'glass for Allen as well since you wanna do a deal with him.' Armfield added that Kiefel as Wells could push a glass towards Allen when he greets him at the beginning of the scene.

The whole scene was then run twice with the whisky and glasses and was marked by the strongly nasal quality in Kiefel's voice. Armfield then asked Kiefel

What's happened to your voice? Your voice is too extreme. It's sounding like an old bookie. It needs to be somewhere in the middle of what you've got and the new addition.

Hugo Weaving in response to the scene commented that he felt 'like such a righteous bastard.' Armfield replied that it wasn't 'necessarily a bad thing as he's [Allen] on a mission from God.'

Armfield concluded that the 'shape' of the scene felt 'quite good', with which Kiefel concurred. The rehearsal concluded and the company broke for lunch.

The approach in assembling the scene showed a marked similarity to that of the 'barbecue scene' in that some time was spent on exploring the actors' starting positions with suggestions coming from both Armfield and the actors, which were then tried out and either accepted or rejected. These suggestions were often made in the form of questions that began with 'what if' and reflected a genuine search for the 'best' starting option, which ultimately would be decided upon by Armfield. However in doing so, he would often ask the actors and even the stage manager for their seal of approval — a form of cross-checking that was consistent with the 'cross-referencing' that Armfield has alluded to in describing how the company initially reads and discusses a play (quoted earlier, see Chapter 3.1 pp. 27).

Apart from the physical placing of the actors in the space Armfield had also been quite deliberate in aurally blocking Kiefel's voice, in finding what was to him a good balance between Kiefel's initial choice of voice for Wells and a 'Richo'-inspired nasal tone. The use of small set items and props, chairs and whisky glasses were also explored and defined. Though it had been Russell Kiefel who had suggested that only one chair be used and that he start with a whisky Armfield had taken on Kiefel's suggestions and expanded them and linked them to the action structure of the scene; that is, the power struggle between the two characters and the attempted deal making by Wells. Armfield's patience as a director was also revealed by the fact that he was unfazed by Kiefel's whisky suggestion even though it had come after three hours work on the scene and towards the end of the rehearsal and had the potential to alter the blocking in the scene. Armfield had merely incorporated the pouring and drinking of whisky into the character's manoeuvres within the scene. Kiefel's own reason for why he had waited for so long to introduce the 'suggestion of the whisky and glasses' is that in his words: 'sometimes an actor has to wait to see where a scene is going before he can suggest a piece of business' (see Appendix 4.) — a reflection on how the actor in this instance is sensitive to incorporating their own ideas within the director's initial shaping of the scene.

Due to the diminishing amount of rehearsal time, the scene was not worked on again before the first run of the third act on the morning on day twenty-one, four days later. Before the run

Armfield advised the cast that almost every scene started immediately after the last one finished and therefore not to be caught napping (there were thirty-two scenes in the act). As it was, the actors in the second scene missed their cue. Armfield commented after the run that they shouldn't 'regard it as time to learn lines' but the 'purpose' was to 'watch and see how you fit into the play.' He added that it was 'crucial' that they listened to 'each other particularly where everything [was] so linked.' On a positive note he concluded that 'there was some fantastic stuff there' but they however, did 'need quite a lot more time' — time which they did not have for the whole play was scheduled to be run for the first time that same day after lunch.

## **7. ASSEMBLING THE PLAY - 'DRIVING STAGE MANAGERS MAD'**

### **7.1. Running the Play**

On day twenty-one the whole play was run through in a former immigrant shed in Marrickville, drowned out by occasional planes. This was one of the three different rehearsal spaces the company would use in the course of rehearsing the *Blind Giant*. The first space had been a church hall in Kings Cross that was spacious though cold, and the third would be upstairs at the Glebe Policemen's club. In the last the table would have to be hoisted up to the floor with the production staff, actors and observers all lending a hand. Kerry Walker was prompted to proclaim as a consequence that they were a 'bunch of gypsies' without a real home of their own. This comment is indicative of the difficulties that even a major alternative company like Company B has to encounter in Australia. With two theatre spaces in constant use at its Belvoir street home, the company at the time had no consistent rehearsal space of its own,<sup>47</sup> unlike its main rival the Sydney Theatre Company which has both theatre and rehearsal spaces located within the same building, on a wharf in Sydney Harbour. Given the length of the play and the need to regularly change the rehearsal space it was a challenge to the company as to what they could achieve after a limited rehearsal time of four weeks, before beginning a week of technical rehearsal and Previews. None of this, however, is unusual in Australia.<sup>48</sup>

As the play was run through for the first time since the end of the first week I noted the following: the play began without the company line-up. In the 'party scene' the gaze was not clear from the chorus tableaux though overall there was a brisk pace to the first act. In the second act the humour in the 'barbecue scene' was apparent and perhaps reflected the detail spent on the

---

<sup>47</sup> The Wilson Street Theatre situated in the Eveleigh Railway Yards was at the time still six months away from being available to Company B.

<sup>48</sup> Marion Potts a director at Sydney Theatre Company has spoken about a standard five weeks of rehearsal which divides into 'read, block, run, fine tune, [and] tech' (Talk given at Performance Studies in 1995). Armfield and Company B's rehearsal on the *Blind Giant* might by comparison divide into five weeks that include read & run; block; block; block; run, tech & fine tune.

business in the scene. This act gave a sense of a performance that was building in momentum. The first scene in the final act needed some prompting and perhaps reflected the less time spent on this act, by comparison with the first two. The business worked well, in particular Kiefel's fingers, his dental floss and the direction for Weaving to speak directly to the microphone. The third act was also noticeable for the drive emanating from Weaving.

To compliment the acting of the ensemble was the soundscape now added by sound designer Paul Charlier and which enhanced the the gathering momentum of the production. The sound design seemed to both enclose and support the verbal and physical text. For example a gently chiming windbell set up an eerie foreboding sound immediately prior to the assassination in the first scene of the play while recurrent industrial pounding accompanied many of the scenes and which for Armfield represented the 'pounding in Allen's head.' The 'pounding' sound was used primarily as an introduction or conclusion to scenes, thus framing them without drowning out the dialogue as had been Charlier's initial concern. That this sound would consistently occur throughout the production also helped to facilitate an aural linkage between the many scenes in the play. The day finished with Armfield noting that they would 'have notes' and pay 'spot visits' to certain scenes before running the play again.

The following morning there was a costume parade. From week three of rehearsal Eadie Kurzer had been costume shopping with the actors and what had been 'found' was now to be shown. Keith Robinson commented that he had a 'reservation' about the 'party hats' intended for the 'party scene.' Armfield responded with Eadie Kurzer's initial design statement that the costumes were not about 'naturalism.' Robinson quickly replied that was Armfield's stock reply. Armfield smiled and explained that he 'liked the statement' the hats made by 'linking everybody.' It was a way to visually highlight the chorus of partygoers while Hugo Weaving would not wear a hat, enhancing his physical isolation from the chorus. Armfield then chose a dress for Cate Blanchett's character, Rose. He looked at several dresses before deciding on a low cut white blouse. The sort of dress he explained, Janice, the party host in the 'party scene' in act one, 'would admire' before asking Rose disparagingly "aren't you cold?" Armfield then asked to 'look at the workers.' The bulk of the company walked on in dark blue overalls with hard hats. Armfield exclaimed that Peter Carroll looked 'great' and was 'very authentic.' While for the Fitzgerald family scenes Armfield liked the 'vulnerability' of the

overalls removed, revealing a simple cotton t-shirt for Doug, Carroll's character.

Armfield then read from several pages of detailed notes that he had made from the run of the play the previous day. He thought the 'train was starting to work' and was looking forward to seeing it work 'on the stage in the actual track.' In regards to the 'party scene' he commented that generally:

It feels like a fight for focus. See in the theatre if it can relax a bit. The crowd needs to spread out a bit. Be good to disperse behind Wells. Feel the whole space. Jason you're too active. It's listening to the Allen and Wells fight [that is the focus in the scene].

Armfield then asked what they were going to do about the way Doug struck Bruce after the latter has narrowly survived the accident in the last scene of act one. 'Does he belt him or is it a strong shake?' Clarke suggested that Carroll knock his hat off and Armfield agreed. Carroll however preferred to hug him (Clarke) and then strike him. Armfield disagreed arguing that

coming in with a strike would be good [and that] it should finish with you [Carroll] embracing Jason [which would] look better than separation for finishing the act — the separation [he added] would come later in act three.

Armfield gave an analogous direction to Keith Robinson advising him to: 'draw the [his] character backwards. [To] think of the character in act three and pull him back' accordingly for acts one and two. In the family scene Armfield still sought 'more innocence and uncertainty' from Clarke and a rising inflection on Bruce's line about previous Aboriginal occupation of the Fitzgerald Land.

Armfield: Its a real character key question, your assumption. First one, is an assumption, ['There weren't any ...'] second one is the question ['... were there dad?']

Armfield also wanted to maintain the sense of simmering tension within this scene and stressed to Hugo Weaving that his admonition to Louise 'we're trying to eat, Louise!' should be underplayed and thus be 'really quiet.' Armfield added that he wanted to Clarke to clean the sauce bottle like a 'machine', unconsciously as Bruce would have done it many times before.

Armfield then paid a spot visit as he had advised he would, in this instance to the end of act two, which he and Stephen Sewell had recognised as a problem area. They both commented that it felt like the act was over before the stage action reached scene seventeen, the final scene. Armfield rectified this by going straight from scene fourteen to seventeen and then in the midst of this latter scene intercut to the smaller scenes fifteen and sixteen. The effect was not unlike film editing and it certainly improved the flow of the act. Cate Blanchett affirmed this direction commenting that it gave greater 'drive' through these scenes. Russell Kiefel and Hugo Weaving then suddenly took Blanchett's enthusiastic 'drive' literally. Kiefel wound up his arms and then his face in a mock crazy drive while Weaving joined in, arms spread wide and performed aeroplanes circling around the wound-up Kiefel, 'Three Stooges-like.' Watching Kiefel Stephen Sewell jokingly asked if 'that was Wells going ballistic?!' (A term used to describe Wells by the CIA operative Carew in the course of the play.) And in a sense it was. The playful anarchy of the rehearsal remained even with the pressures of only one last week of rehearsal. It was arguably a safety valve for the actors' tensions, releasing any stored up energy to maintain a lightness and ease in rehearsal.

The company ran the new edited scenes which worked well in creating an added tension that slowly built. Armfield then said to Sewell that it felt like they 'were looking for a fourth part.' He suggested that Doug would come in and watch Allen during the last part of scene seventeen which traces Allen's affair with Rose Draper. Sewell suggested he could do it as a drunk while Armfield replied he could be just watching and he could say 'you're my eldest son.'<sup>49</sup> The scene was run and Doug's line gave a strong impression of a father's utter sense of failure in his son. Armfield then added that Doug and Allen should look at each other before Doug left on the word 'despair.'<sup>50</sup> This gave a strong sense of the weight of Allen's father, Doug on his, Allen's conscience.

Having Doug watching Allen while not actually in the scene would seem to form a choric function, with Doug becoming an 'audience within the play.' This is how John Golder described

---

<sup>49</sup> This line comes from scene eight in act two immediately following the 'barbecue scene.' Doug tells Allen that he is 'failing' to control his wife Louise. e.g. 'you're my eldest son and you're failing' (Sewell 1983: 64).

<sup>50</sup> In scene seventeen of act two Rose claims Allen's 'rationalisations [are] not a very good defence' against the 'despair' he feels. Allen responds that he is 'not in despair' (Sewell 1983: 79).

the emphatic shadowing of Hamlet by Horatio in the Belvoir production. The idea would seem to be the same: an 'observer', a 'commentator' watching in Armfield's words another character they 'love' (1995: 72). Armfield has said that for Horatio:

it is him looking around and seeing the world spinning hopelessly out of control. (1995: 72)

The same could be said for Doug as he watches Allen's marriage similarly spin out of control. While in *Hamlet* it had just been one character, Horatio watching another, Hamlet, in the *Blind Giant* more than one character would stand and watch Allen. In fact on day ten while rehearsing scene five in act two between Allen and Rose Draper, Armfield had stood upstage left and stated that he thought this would 'be a good waiting/watching area' (see Figure 11.). It was where Rose would stand and watch Allen working alone before entering scene seventeen in act two, where she would in Armfield's words 'see and judge' Allen while remaining 'vulnerable' herself. It was the same localised space that Doug would pass judgement on Allen from. It was also where Armfield would ask Cate Blanchett's Rose to wait and watch during the 'party scene' following the second run of the play on day twenty-three. Although Armfield had abandoned the idea of the whole company watching the early scenes of the play he had still kept a choric function within the company by having individual characters watching and commenting on the play's protagonist.

In the second run of play it was interesting to note that Kerry Walker's 'shooting star' line disappeared from the 'barbecue scene.' This probably contributed to the inner tension of the scene that Armfield was establishing; that is, lines that were considered extraneous were cut, in preference for silences or pauses to emphasize the inner dialogue or subtext of the scene. With Armfield now able to view and plot the rhythm of the whole play it would make sense that he was further underplaying the scene in order to set up the dramatic convulsions of the third act, when Bruce leaves home. The form of the scene was reminiscent of the style of writing by Chekhov in the *Cherry Orchard*, where according to Peter Brook the character's 'punctuation, periods, commas, points of suspension [reveal] what the words conceal.' Like Chekhov Sewell is presenting 'a microcosm of the political tendencies of the time' (1988: 157). In this instance a society convention, a barbecue with a prescribed decorum, which masks inner family tensions. As in Chekhov where much use is made of subtle sound effects Armfield enhanced the tension of the scene

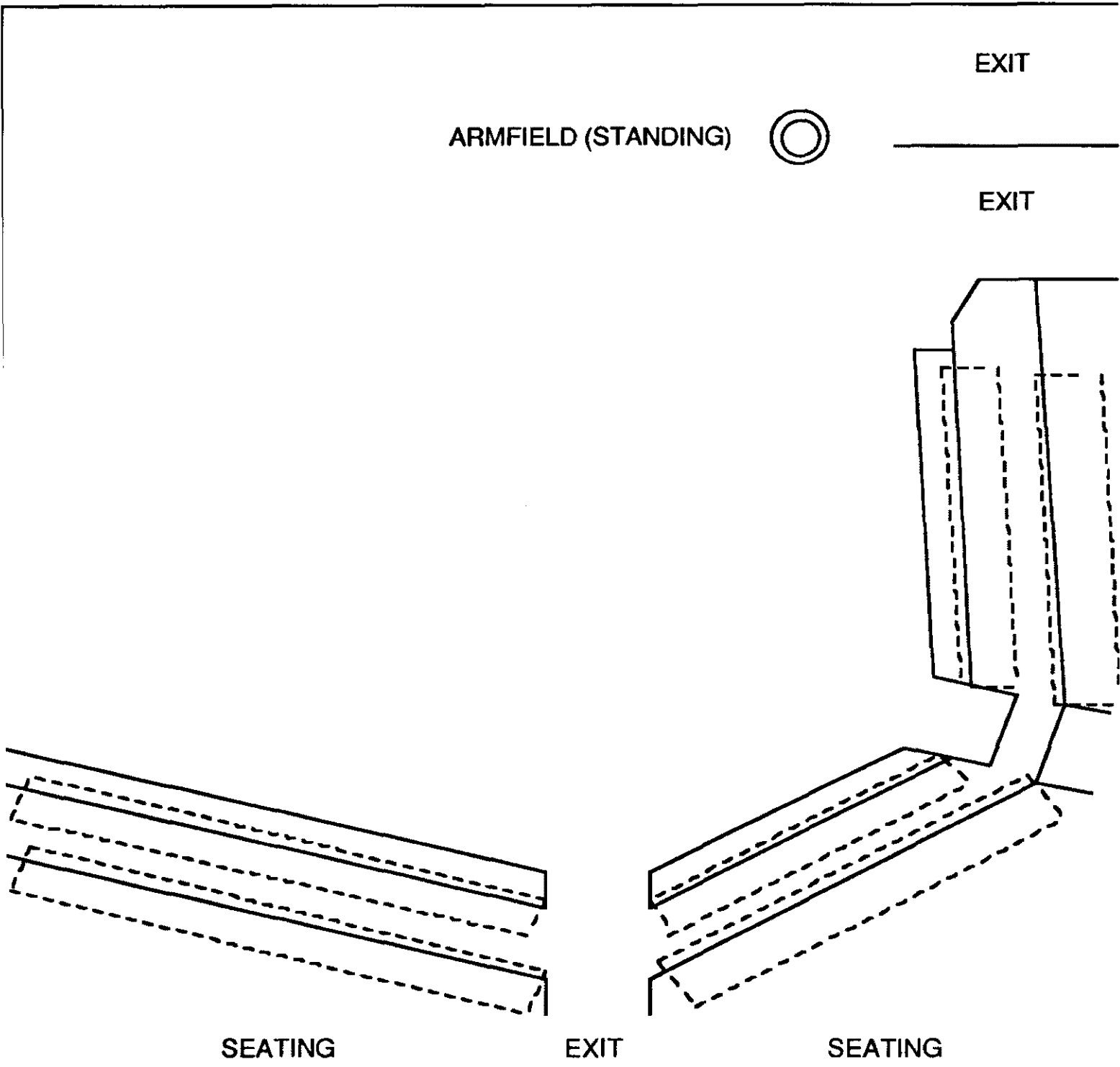

Figure 11. Armfield establishes a choric space from where various characters would stand and watch Allen in the course of the play:

Armfield: I think this might turn out to be a good waiting/watching area.

by taking the sound of crickets up to almost an unbearable level in the scene — a level that was equally 'alienating' as the 'impressions' in Chekhov (1968: 89).<sup>51</sup>

The detailed business in this scene kept coming and was spread amongst the cast. For example Armfield asked Walker to 'pop something in [her] your mouth' on her line: 'man's greed' — a form of comic allegory that was consistent with the 'level of mirth' he was developing in the scene. Armfield again reminded Clarke to variously leave the 'h' out of 'nut-house!', to make the line: 'there weren't any out there' more 'automatic' and to clean the sauce bottle in a 'machine-like' manner. One could surmise that as a relative newcomer to the company Clarke was more resistant to Armfield's detailed direction than were other company members who had worked consistently with Armfield before. An observation perhaps borne out by the fact that Armfield had closed the rehearsal room to both observers and other members of the company only once in the course of rehearsal. This was when rehearsing the scene in act three when Bruce leaves home, a scene that Armfield had identified as a turning point in the play. 'Kazz' Rodgers the stage manager confided in me at the time that it was because Clarke was 'really blocking' the scene. However I noted that by the second run Clarke had achieved a good sense of shyness in his playing of Bruce, particularly when Doug reveals to Allen that Bruce has a girlfriend — a shyness that was close in quality to the sense of innocence sought by Armfield.

At the beginning of act three Armfield asked Russell Kiefel to 'burp before' he said the line: 'I've got a whole bucketful [of political 'shit'] I'd be delighted to tip over you' to Wells and to 'make the floss go ping' — a physical and comical commentary on the political machinations of power that mirrored the comical commentary on domestic tensions within the 'barbecue scene.' Armfield then summed up the second run of play commenting:

I thought that was generally a good step forward. I think it will be fantastic; there's a huge amount of work that needs to be done. We all know which way to go. All of our decisions as they become more clarified have worked. It's like lets get on this roundabout and not get off until next week.

---

<sup>51</sup> Brook in *The Empty Space*, talked about Chekhov's 'slice of life' being built upon a 'series of impressions' that were 'equally alienations' such as a 'fire engine that passes at the right moment, distant music,' etc (1968: 89).

## 7.2. 'Teching' the Play

The technical rehearsal began the next day, day twenty-two, with Armfield finally in the theatre and advising that they would go 'moment by moment.' He moved around the stage a great deal checking for sightlines and audio quality while giving detailed and precise direction to the actors and the stage manager as they worked through the play. He cued the sound effects, the actors' entries and exits while giving them notes on individual lines as well. Scenes were run in their entirety, often several times and some were reblocked. The table initially stuck and required working several times. Armfield commented that he 'liked the sound it made' and that it served the 'purpose.' This 'purpose' was reaffirmed to me by Stephen Curtis who told me that the reasons behind the use of the table were variously so that the 'actors didn't have to carry props on and off', that the play needed 'a machine to propel it' and the need for the design to be 'properly motivated' and not simply 'decorative.' The table had in fact turned out to be extremely versatile and mobile in representing different spaces, for example a train carriage, kitchen and dining tables, a broken steelworks channel and various office desks thereby defining and delineating the performance space. Whether stationary or being pushed or spun it was infinitely flexible in establishing the locations of the play. It was the major determining signifier of the stage design that continually mapped out the changing geography of the performance space.

The action for the 'train scene' was reaffirmed by Armfield as happening in the central downstage area. For the 'party scene' the entry was tried several times without music with Armfield reminding the cast 'not to forget that they come on dancing wild' which he again demonstrated. He added that they would 'freeze' on the word, 'world' from the accompanying song *Revolution* but then later would 'keep moving' with 'small' movements and with their 'eye' on Weaving and Blanchett. He also asked the cast to 'spread across the space at the back and to be silhouettes' to the main action downstage. Kerry Walker asked Armfield if he wanted 'any laughs?' He replied 'just ripples' and 'wherever' she and the company would 'like to make a contribution.' That night they worked on the 'accident scene' with Armfield advising Carroll to

knock Bruce's helmet and him over; [to] scream [and] shake him with both hands after you've hit him ... then hug him.

All the possible actions that had been explored in finishing this scene were thus now combined. The act would then end with the industrial pounding sound and a safety siren which would in Armfield's words 're-emphasise the drama' of the play.

The next day the layering of detail continued. Armfield variously instructed Clarke to load his plate up with salt and Weaving to give more a sense of 'disquiet' on the line: 'we're trying to eat, Louise!' in the 'barbecue scene.' The transition from this scene to the next was done four times as Walker walked downstage with the sound of a distant train slowly fading. Armfield then instructed Karen Rodgers to 'take up the cicadas' to the unbearable level discussed earlier — the volume of the cicadas was particularly noticeable and alienating as Allen paused to respond to criticism from his father. The precision that Armfield applied to this sound cue was evident throughout the technical rehearsal. He also apologised to Keith Robinson when he reworked a scene stating: 'I know I'm putting a lot on you reblocking at this stage', but added that 'it needs to be done.'

The third day of technical began at 2:00 P.M. and finished after 9:00 P.M. — a continuation of the pattern established over the past two days. Armfield used the technical to not only cue sound and light cues but also to rework whole scenes where necessary. For example he spent three quarters of an hour reblocking scene ten in act three where Bruce finally leaves home after a violent argument with his father, Doug. Armfield arguably spent this time on the scene because he had asked both Clarke and Carroll to hold their characters back until this moment and the fact that they had had limited rehearsal time for this act. In Scene Thirteen where Wells meets with the CIA power broker Carew, played by Keith Robinson, Armfield had Weaving as Allen watch from the 'waiting/watching area', thus able to observe the continued demise of his rival and anticipate his imminent rise to power. It was consistent with Armfield's use of individual characters as choric witnesses, but it cleverly reversed the previous convention of Allen being watched by Doug, his father and Rose, his mistress. Now Allen was the watcher, the would be pugilist even as Armfield directed Weaving to 'relax into it like a waiting boxer.' Typically in a scene about Wells' demise Armfield blocked comic allegory by asking Kiefel to do some of his 'crab fingers' (running his fingers along the table) on Carew's criticism that 'you're losing your grip.' This the last day of 'tech' finally finished at 11:30 P.M. The feeling in the company was best summed up by Karen Rodgers when I asked her how she was. Her reply: 'knackered.'

Next day — day twenty-five — Armfield asked me to prompt during the dress rehearsal but I didn't have all the script changes. He then asked me, following Peter Carroll's suggestion, to 'sit on prompt side' and note 'any lines that are hard to hear especially with the sound effects.' The previous day there had been talk of consulting my notes to check the blocking in a scene. My role was slipping from observer to participant: not only 'co-producing knowledge' about the way Company B worked but becoming an unofficial company member myself. I subsequently made seven pages of notes on lines that were unclear, unheard or drowned out by sound. However I was only able to give one note to Kerry Walker which she took gratefully as the following note session was cut short.

As in his previous note sessions Armfield gave a general note for all the actors before proceeding through the play in detail. This time he advised that 'there are lots of laughs locked in the show [and that] you just have to break your own rhythm' to find them. The run itself was unfortunately characterised by Weaving's inability to unlock the table for the 'accident scene.' It emerged that he hadn't been instructed in how to do this and this was the last run before the first previews. Armfield then calmly reiterated how to effectively push the table with equal pressure on both sides. Despite the approaching preview, the notes were as detailed as ever. He wanted variously for the company's entry to the party to 'explode' and he gave specific cues for the party chorus to dance, freeze, 'strike more of a pose' and laugh. He advised Steve Rodgers, as he had Weaving, to relax into the scene and not to 'push it too hard' but to 'broaden it out.' In the 'barbecue scene' he reiterated to Weaving to 'take' his 'time' and to 'have more disgust' on the line 'we're trying to eat, Louise!' Karen Rodgers then suddenly spoke quietly to Armfield and the note session was cut short; the actors were owed time — Russell Kiefel in particular looked exhausted — and needed to rest before the evening's performance. This is perhaps the down side of using a long technical that, while adding focus, clarity and detail to the production, the company is temporarily exhausted in the process.

Karen Rodgers, I noted at the time, had done a wonderful job in driving the rehearsal: getting people on and off the stage and

coordinating the sound and lights, allowing Armfield to be freer in dealing with the cast. Kerry Walker noted to me with an experienced eye that 'Kazz' was part of a breed that were so energetic and organised that they needed to take great care not to 'burn out' too quickly. Part of the reason that Rodgers seemed to retain her sense of equilibrium was her empathy for and understanding of Armfield's process. A conversation that I had with her was revealing in terms of her conception of Armfield's working method:

Neil sketches generally in blocks. He hates fixing things too early. He changes the blocking up until the last moment.

Peter Carroll put a slightly different slant on working with Armfield when he commented to me that:

Neil doesn't like to conceptualise too early as you never know what it might become later on.

Armfield himself has commented on his propensity to use technical rehearsals not just as the moment for bringing the elements of a show together but as an opportunity to rework scenes as required, which is why his technical rehearsals are much longer than the norm.

I tend to drive production managers mad because I do like to have a very long technical rehearsal. The old way is to ... rehearse moving from lighting cue to lighting cue. A long slow tech is much more creative. You just work through the play really slowly and it's lit from that experience rather than the other way around. (in Stewart 1995: 16)

This comment reflects Armfield's use of technical resources to actively support the storytelling through the actors. It is why whole scenes were run in the 'tech' rather than the traditional topping and tailing, enabling a greater fusion of in Armfield's words 'all the ingredients of the physical piece of theatre coming together' (in Stewart 1995: 16). It gave more time to Armfield and the actors to assimilate what they had developed in rehearsal in characterisation, character relationships, physical and aural blocking with the actual theatre space, lights and sound; an approach which differs markedly from the conventional, and by comparison limiting practice of working from cue to cue.

### 7.3. In Performance

The first preview audience found the 'barbecue scene' hilarious. When the *Blind Giant* opened after two more previews the critics felt the same. John McCallum commented in the *Australian* that:

Peter Carroll and Kerry Walker, as Allen's parents seem to have wandered in from another play, so real and human are they in the painfully comic barbecue scene.

(in Jordan 1995: 7)

James Waites from the *Sydney Morning Herald* went further stating that:

For all its political pungency and scope the most powerful scene in this production is the family gathering, a barbecue where tensions simmering below the surface rise only to be forced down. This scene — worked up to a level of hypnotic clarity by Armfield and his superb cast — caught the opening night by surprise. It was then we knew we were witness to a remarkable theatrical effect. (in Jordan 1995: 6)

Armfield's emphasis on detailed comic action, pauses, inflections to accompany Sewell's text had evidently worked to draw the audience into the politics of family life through humour. I also noted at the first preview that there was an overall good flow to the progression of scenes, which went quite quickly. The company had found a performance energy for its first audience, although Weaving was noticeably very tired in the third act.

There were notes the next day — day twenty-eight, a Sunday afternoon — the last notes that I documented. Peter Carroll asked Armfield to give an 'overall sweeping impression' of the preview which he thought had been 'raw, exciting [and] sexy.' Armfield responded that 'if [he] did that he [would] make things up [that would] confuse things' rather than focus the performance. He then proceeded as before with detailed and precise instructions on particular moves and lines, some of which were simple reminders of previous business like Weaving's 'icky pause' on 'we're trying to eat, Louise!' in the 'barbecue scene.' Armfield, while being immersed in specific details, was able however to keep a broad view of the play; the 'dance' of the play, as he had called it. He

suddenly gave a general instruction to Russell Kiefel:

Your voice can loosen up, become more playful.  
Work on the way you say 'power' — it should be memorable.  
Really possess the word because you say it quite a lot.

Armfield added that he also wanted Kiefel to give some words a flattened 'strine' accent, which he demonstrated. The identifying characteristics of voice, 'hairdo' and posturing of Kiefel's Wells that Armfield had helped to construct were readily traced by James Waites who wrote that:

Russell Kiefel as the cynical Wells has also never been better; the body language (and shape) reminiscent of that not long departed Right factionary Graham Richardson, (in Jordan 1995: 6)

Paul McGillick, writing in the *Financial Review*, noted Armfield's attention to detail, commenting that Armfield 'elicits performances which are engrossingly underplayed and detailed' (in Jordan 1995: 8). In the above last note session before opening night Armfield continued to patiently reiterate this 'detailed' direction to the cast. For example he asked the whole cast to clearly focus the train images and to all sing *Revolution* at the start of the 'party scene.' Individually in the 'barbecue scene' he reminded Clarke to highlight his working-class, country dialect by dropping the 'g' from 'nothing' and for Walker to emphasize the comic allegory of 'stuffing' her mouth on the line 'man's greed.' At the beginning of the third act he wanted Kiefel to not 'hide the floss, but expose it.' Overall he commented that the lines in the third act had to come on top of each other to keep the drive of this long play moving forward.

In the first week of rehearsal Kerry Walker had advised the company to approach the playing of their characters by eschewing personal judgement and allowing the audience to 'judge' — a distanced Brechtian-like demonstration of the character's qualities. Ironically Walker had realised her character by a compassionate portrayal of Eileen Fitzgerald, thereby eliciting an empathy from the audience, rather than a frank exposure of the character's faults and feelings. In Pamela Payne's words 'the limited kindly mother in her best apron and worried peace-keeper smile' (in Jordan 1995: 7). Walker summed up this sense of empathy with the audience, commenting after the opening performance that 'the audience was with us in both mind and

heart.' Gillian Jones similarly felt that the audience had been 'very tractable.'

Waites applauded both Catherine McClements and Cate Blanchett for their performances, 'wonderfully charged' with 'feminine energy independent and bold in their outlooks' while he thought Weaving had found a 'springboard into his bravura characterisation in the blunt unforgiving Australian-ness of Sewell's language and outlook' — a characterisation that was 'clever, searching, tortured from within' and which showed how Allen was 'corrupted into everything he once loathed' (in Jordan 1995: 6). McCallum thought that outside the 'Faustian pact' that Allen makes with world of politics it was only in the 'vulnerable encounters with his family' that the audience felt the 'emotion of guilt, disillusion and betrayal' (in Jordan 1995: 6-7); hence the importance of the family barbecue as a ritual of revelation that Armfield had recognised and finely focused on.

Tim Rowse in *Arguing the Arts* thought that the Australian language has been finally 'accepted' on the Australian stage in the 1970s by 'the exploration of the comic and poetic potential of the vernacular' of the country or working class through playwrights such as John Romeril and Jack Hibberd and through the study of the 'middle class' by a David Williamson 'naturalism' (1985: 70). Sewell's writing in the *Blind Giant* arguably straddles both classes, which Armfield accentuated by alternatively layering comic action on top of Sewell's naturalistic dialogue in the political world of the play while allowing powerful emotions to be initially, forcibly restrained under the country and working class vernacular of the Fitzgerald family. James Waites felt that in the *Blind Giant* Sewell was the only Australian playwright to 'embrace both the personal and the political, separately and as each exists within the other' (in Jordan 1995: 6-7). McCallum echoed this, commenting that 'public crimes are reflections of private evils' (in Jordan 1995: 6). The personal is continually put up against the political; a formula familiar from Greek tragedy. Armfield's production offset the play's tragedy with almost lazzi-like comic routines. The combined result was reminiscent of the alternating tragic/comic scene structure of Shakespeare. Brook has described that in Shakespeare:

It is through the unreconciled opposition of Rough and Holy [comic and tragic] ... that we get the disturbing and the unforgettable impressions of his play. (1968: 96)

In Sewell's play there is analogous 'opposition' between middle-class language and country, working-class vernacular which Armfield and his cast exploited. In this respect it is interesting to note Armfield and the Company B ensemble's prior grounding in Shakespeare and its language structure with verse alternating with comic prose — the company's familiarity with these two text forms may well have contributed to the performance style brought to the *Blind Giant* of clearly contrasting the 'holy' tragic with the 'rough' comic. For example Carrie Kablean writing in the *Sunday Telegraph* noted the 'complete contrast' between 'Sewell's principal mover ... [a] 'taciturn, brooding' Allen Fitzgerald and 'the confused and sad mother, [who was] sometimes painfully funny' (in Jordan 1995: 8). Waites in turn contrasted

Weaving's Allen [as] a man of idealistic and principled origins [and] ... poison in his blood [with] ... Gillian Jones' hilarious (birthday) party animal [and] Steve Rodger's disgusting freelance economist and banker Bob Lang.

Waites also pointed out the political and domestic oppositional qualities in Sewell's writing which was not so 'facile' to be just about:

how the world works on us as people in this age of late capitalism ... [but with] the focus on the inner workings of the Fitzgerald family the play could easily be dubbed a domestic drama. (in Jordan 1995: 6)

For McCallum such a 'large play' needed a 'large production' with accompanying 'acting that stretched itself' and in this production it was the 'performances that had generated the power ... supported by a staging and music that was simple, industrial and austere' (in Jordan 1995: 6-7). Pamela Payne described a

minimalist rigour ... superbly supported by Stephen Curtis' stage design; ... [highlighted by a] table on casters [that was] ... hurled and clanged into position according to the scene: kitchen, party headquarters, steelworks ... [while] Paul Charlier's music [was] industrial, elemental, full of pent-up danger and foreboding or stirring, ecclesiastical, bitterly ironic. (in Jordan 1995: 7)

The design had according to Kablean enabled the 'train scene' to convey a 'sense of urgency' as Allen was 'shunted back and forth oblivious to the chaotic surrounds.' McGillick thought that Curtis and Armfield had left the 'stage wide open' with the table 'used brilliantly to set scenes — and as a metaphor for the distance between people' (in Jordan 1995: 8). Waites echoed this commenting that in keeping the 'stage bare' except for the table which served as a 'great divide across which the characters argue but rarely find resolution' Armfield had pushed 'beyond his known limits once again' (in Jordan 1995: 6). Waites was also one of the few reviewers to comment on the costumes which he felt had been 'superbly observed' (in Jordan 1995: 6-7).

Criticism was limited and centred on the text. For McCallum the *Blind Giant* was a 'masterpiece ... unwieldy and structurally flawed as *King Lear* or *Hamlet*' while according to McGillick 'after a brilliantly emblematic first act, the play becomes discursive and expository' but which Armfield and Company B had nonetheless still made 'indispensable' (in Jordan 1995: 6-8). Overall critical response had given high praise for the production which was matched by a sell-out season. Above all there were consistent references to ensemble-playing. Pamela Payne for example reiterated Armfield's own stated ideal of a 'shared vision' commenting that:

from all 12 actors there's that consistency of tone that can only come from a shared purpose, shared vision of the play. Everyone of them establishes a character of trenchant plausibility. (in Jordan 1995: 7)

John McCallum said he didn't 'know how' Armfield and Company B had made 'this huge play work' but then offered the thought that it might be what is called 'giving the actors room to move.' He concluded that 'Armfield's productions have a specific feel about them, yet they remain actor's shows' (in Jordan 1995: 7). This comment would seem to support Kerry Walker's statement, that democracy in Armfield's rehearsals means that the director allows the actors time or 'room' to explore various 'options' before making a decision. Similarly Peter Carroll's comment on the 'collective understanding' at work in the company could be viewed as contributing to this apparent empowering of the actor by the director and the resultant 'shared vision' felt by audiences.

Finally, according to Kablean the production had indeed reflected Armfield's aims for the company's ensemble, expressed in the program, by providing a

form 'ultimately greater than the sum of its parts.'

A view similarly supported by McCallum who observed that the production reinforced

the intersection between this play's theme and this company's structure: that people together are stronger than when they are alone. (in Jordan 1995: 6-7)

## 8. DEMOCRACY IN THE REHEARSAL ROOM?

### 8.1. Before Rehearsal.

Taking into account how the theatre institution affects the theatre event both economically and culturally is now recognised by scholars as critical in analysing the theatre event itself. Once it had been confirmed that I would observe the rehearsal of the *Blind Giant* I was sent a folder of information from Company B concerning the forthcoming production which already indicated certain resource and economic limitations on the company. The folder contained a map of where to find the rehearsal room and a rehearsal schedule. The former, a church hall in Kings Cross, would be one of three rehearsal rooms that the company would be forced to move to and work within while another Company B production was being performed in the theatre at the same time. In the second rehearsal space at Marrickville, Armfield looked on in envy at the nearby rehearsal room of a well established community theatre company<sup>52</sup>; one wonders if he had such stable conditions to work under, how much more could be achieved by his company, which had been forced to become in, Kerry Walker's words, a pack of 'gypsies.' Adding to this disruption was a rehearsal schedule which showed that in the fifth week of rehearsal the play would open to the public — an indication of how tight time was for such a long play to be produced ( although, unfortunately, this is not uncommon in Australia). The limitations of the company's resources, low 'economic capital' in Bourdieu's words, also meant that the actors were all paid the same — significantly less than at the Sydney Theatre Company (1993: 6). Although all were paid above the equity award there was no hierarchy of scale based on experience as is stipulated by this award.<sup>53</sup> However this arguably contributed to creating a genuine feeling of equity between cast, a 'shared quality' in Armfield's words or an 'internalised code' within the ensemble, which Armfield saw as being translated onto stage (Bourdieu 1993: 7).

---

<sup>52</sup> The Company was Sidetrack Performance Group.

<sup>53</sup> The equity award indicates a minimum rate of \$ 639.80 for an actor with less than three years experience and \$ 681.50 for an actor with more than three years experience.

Kerry Walker's comment that all of the actors in the ensemble actively and equally 'support' each other no matter what their role reflects the strength of shared artistic practice between herself, the other veteran actors and Armfield over twenty years of work together — a 'cultural knowledge' of how to work effectively together in such conditions of low 'economic capital' (Bourdieu 1993: 7). Walker, like Carroll and Kiefel, made up the core of the Company B ensemble and possessed the cultural code or 'competence' to 'decipher' the *Blind Giant* (1993: 7). Thus prior to rehearsal the company's economic limitations were offset by this cultural 'competence' or 'knowledge.' Indeed the strength of the ensemble was its 'cultural capital,' principally embodied by Armfield, who, as artistic director, had been able to make the decision himself to mount the production, rather than this being dictated to him by a board or artistic counsel (1993: 7). The play would support his then stated aim of developing the Company B ensemble, as the *Blind Giant* was a good vehicle for an ensemble company. Armfield had premiered the production with the Lighthouse ensemble which, it could be argued, now served as a model for the Company B ensemble. Armfield, for example, revealed on the first day of rehearsal that the company, would initiate a 'new relationship' with the writer Stephen Sewell which was reflective of the way Lighthouse had worked with writers. Armfield also quoted the Shakespearean model as another influence, citing the value of having a fixed company of players (in Golder and Madelaine 1995: 59). Overall the production represented a strategy of cultural 'accumulation' for the company drawing on not only the success of company's prior productions but also the extensive theatre making experience of its core members (Bourdieu 1993: 7-8).

The philosophy of 'collective creation' in alternative approaches to text-based theatre has frequently foregrounded the empowering of actors, by allowing them to contribute to the development of design, in distinction to the mainstream practice of the design dictating to the actor (Pavis 1998: 63). Nearly every actor who has worked in the State Theatre Company system, it would seem, has had a bad design story, where they have not been able to integrate with a design constructed prior to rehearsal by

the designer and director.<sup>54</sup> In Marxist terms the actor is thus

alienated in the labour process itself — they have no control over how things are done and what is to be produced ... [while] Theatre collectives and collaborative creation are attempts to escape such alienating structures of capitalist and mainstream theatrical processes. (Fortier 1998: 8)

Some examples of alternative approaches to design conceptualisation include that taken by the Canadian director Robert Lepage on a production of *A Midsummer Night's Dream* (at the National Theatre in London 1992). Lepage spent a week — two months before rehearsal formally began — to specifically research and explore the design with the actors (in James 1992: 14). The dominant design concept that came out of this week's work by the group and which subsequently infused the production was to cover the stage with mud. Similarly Rex Cramphorn in a production of *Anthony and Cleopatra* with the Actors Development Stream (at Playbox Theatre Company, Melbourne 1985) followed a pattern of rehearsing in two blocks of four weeks and six weeks separated by three months. After the first period the design 'evolved' from Cramphorn and the designer Eamon Darcy's initial idea of a central pavilion to 'multiple movable towers' following 'extensive discussion' by the entire group. The group would then be free to find 'meaning'<sup>55</sup> through exploring the positioning of the towers and have the 'flexibility to quickly clear and transform the stage space' (Minchinton 1998: 138). More recently Barrie Kosky was 'allowed' eight weeks rather than the 'customary four weeks' to rehearse *Oedipus* for the Sydney Theatre Company. Kosky started rehearsal with 'hundreds of ideas

---

<sup>54</sup> The Australian actor Susan Lyons for example has commented that 'it is very frustrating that set and costumes are already decided' before rehearsal. She gives a specific example where a set design for a production of *A Midsummer Night's Dream* was so 'complex that' she and another actor 'couldn't find two equal places of power and couldn't start the scene between Oberon and Titania.' (Quoted during a workshop of *Old Times* by Pinter at Performance Studies 1995). In the same workshop fellow actor Brandon Burke spoke of 'one of the great disasters of all time' when the English director Jules Wright set 'the play [*The Revenger's Tragedy* for the STC] in Italy before the Second World War.' The actors discovered that the text had 'more life to it, more scope and more places to go.' What was 'shocking' to Burke was that 'all the discovery that one was making was going nowhere' because of the directorial and design, conceptual constriction.

<sup>55</sup> 'Finding meaning through position' was achieved by Cramphorn and the actors through an investigation of 'the "emotional geometry" of the play text ... in response to the spatial dynamics ... in the playtext' by actors freely exploring positions for themselves and the movable set as Cramphorn 'watched and listened to their work' (Minchinton 1998: 135).

and not a single decision made' (Litson 2000: 15). Kosky said by the final week of rehearsal that

thank goodness there were no [early design] decisions [made] because in the examination of the musical, physical and psychological world that we were creating basically everything I thought would work was proved not to work and vice versa. (in Litson 2000: 15)

Armfield has reflected this same thought commenting that:

it's a necessary state to enter rehearsals without knowing too much. You can't know how a play works until suddenly it's a tactile experience. It's kinaesthetic and, more than anything else probably, it's psychological. It's the mix of minds and personalities and bodies that is the stuff of theatrical experience. You can't predict what it's going to be. (in Stewart 1996: 16)

The design arrived at for Kosky's *Oedipus* was 'staging the entire piece, with a cast of 10 on a 2.5m sq performing area ... a stripped back production with "a still intensity"' and which foregrounded the text's 'extraordinary visceral language' (Litson 2000: 15). Kosky stated that

one of my biggest complaints about so much theatre [is] the director and designer have had a fabulous idea six months ago, then the production and the actors are made to fit within that. Sometimes it works and sometimes it doesn't, but it's always clunky and I'm not interested in doing that anymore. (in Litson 2000: 15)

All of these examples of theatre design were developed within rehearsal and had lengthy rehearsal and in the first two, ingestive periods in between to evolve within. Company B would have only five weeks for rehearsal on the *Blind Giant* and it is therefore not surprising that Armfield and Curtis were forced to make a prior decision on the show's design. However, where Curtis' design was both clever and functional was in the design feature of the large mobile table which, while shaping the performance space, could be moved by the actors to whatever position they and the director preferred — a flexibility that gave the actors a voice in the manipulation of the stage space and which echoes Cramphorn's approach. Curtis explained that the design reflected his 'previous work with Neil' which placed an emphasis on 'presenting the actor strongly' and the 'flow of

action' between scenes — a 'reductionist'<sup>56</sup> design that Curtis articulated as directly opposite to the overly 'realist' design in a STC production that had tied the action down to 'mincy' detail.

The set design represented a compromise between a priori decision making and being conscious of the actor's needs. The table would, in Curtis' words, 'drive' the play and the company did indeed push, pull and turn the table across and around the stage in a variety of configurations that altered both the 'stage space and 'gestural space'<sup>57</sup> from scene to scene. The table also operated to physically separate the characters, literally expressing one of the themes of the play. This was intended by both Curtis and Armfield who saw it as 'dynamic obstruction' that the actors had to work around and was noted by critics. It was a design structure that allowed the actors to move within defined physical and thematic parameters. This primary design signifier was a given but the action of positioning the table was actively explored or in both Curtis and Armfield's words 'found' in rehearsal by the director and actors. This in turn repeated how the company had rehearsed their previous production of *Hamlet* where they had been able to 'change the space ... from act to act' (in Golder and Madelaine 1994: 61). In both productions of *Hamlet* and the *Blind Giant* a 'lesser violence' was arguably done to the actor's 'sense' of ownership of the 'overall project' by the director and designer (Fortier 1998: 8-9). Armfield and his designers' mobile designs were intended to be fluid enough to be manipulated by the actors. This inclusion of the actors in developing the use of the design in rehearsal could be viewed in a larger context as part of a 'struggle for a more humane [and] more democratic process' in current theatre practice (1998: 8-9).

---

<sup>56</sup> Paul McGillick describes 'experimental theatre' as being divided into:

Oposing ideologies — the eclectic and the reductionist. The eclectic tendency [focuses on] ... movement and music, ... [the] *mise en scene* ... the design while reducing the importance of the text ... The reductionist ... seeks to strip away the extraneous in order to rediscover the uniqueness of theatre — usually the physical reality of the action. (in Parsons 1995: 218)

The 'reductionist' approach would also seem to reflect the approach taken by Barrie Kosky to his recent production of *Oedipus*, unlike his approach to earlier opera productions, which have generally been regarded as veering towards the 'eclectic' (although not by Kosky himself) (Litson 2000: 15).

<sup>57</sup> Patrice Pavis defines 'Gestural space ... [as] the space created by the actors' movements ... while ... stage space ... is limited by the structure of the building.' Both are shaped by the set design. The fact that the actors were themselves moving the table from scene to scene meant that they were in performance determining a dynamically changing 'stage space' through their own 'gestural space' (1998: 163).

In an analogous way Armfield stressed that this 'found' philosophy would inform the costume design, which would be constructed 'around character' development. Costumes would be developed 'through rehearsal' and follow once the character's 'state' had been identified and not before. This would seem to be opposite to the mainstream pattern of design dictating to the actor.<sup>58</sup> Armfield and Eadie Kurzer did fix certain parameters such as a general 1980s period, and pre-determined some elements of clothing such as Allen Fitzgerald's jacket which would have 'symbolic' value, and is referred to directly in the text of the play. Within these parameters there was however freedom for the actor to contribute to the decision on what costume they would wear as they went 'op' shopping with Kurzer from the middle of the rehearsal period onwards. The final decision on costumes was by state theatre company standards, five weeks late. The actors presented the choices that they had made with Kurzer to Armfield at the beginning of the technical week. Armfield for the most part accepted these choices, or chose between one of several options on offer. For example one of Russell Kiefel's three memories of 'creating the role of Wells', five years later, is '*choosing* [my italics] to wear a red cardigan' (See Appendix 11.4.).

Unlike mainstream labour processes, where the design is presented in the first week, the costume design was intended by Armfield to be 'developed through the rehearsal process', as would the music complementing and enhancing the work done by the director and actors. Certainly this approach would seem to be less alienating for the actor. It mirrors the 'work in progress' approach taken by director Peter Hall at the National Theatre in Britain (*Anthony and Cleopatra* 1990), where the 'design is following the rehearsal process and incorporating ideas to which they [the actors] are party too' (Lowen 1990: 22). This 'minoritarian' approach reflects an extension of the traditional theatre design paradigm away from pre-rehearsal design conceptualisation to conceptualisation within rehearsal, where set givens are flexible enough in their mobility to allow ongoing input from the actor during rehearsal as to their positioning — a 'deterritorialisation' or breaking down of majoritarian

---

<sup>58</sup> Simon Callow for example has remarked that

Every actor has bitter experience of costumes which have betrayed his conception of the part ... [and he prefers a] passionate bartering on both sides, the designer fighting for her vision, the actors for theirs: a very healthy relationship. (1984: 160)

design/rehearsal practice and a 'reterritorialisation' of theatre process at another level of practice (Pavis 1998: 80). Time would seem to be a critical factor as all four of the alternative examples cited here had significantly longer periods of rehearsal than the *Blind Giant*, allowing a greater opportunity for set design exploration within rehearsal. Costumes and music for the *Blind Giant* were however, for the most part decided in rehearsal. Overall the approaches of the director and the set, costume and music designers to the production foregrounded 'the physical reality of the action and the actor's presence' by offering the cast a flexibility within a fluid design structure (in Parsons 1995: 218).

## 8.2. Alternatives within Tradition

On the surface Armfield structured the rehearsal in a traditional manner with discussion and analysis followed by blocking, runs of the play and technical rehearsal. However, Armfield and the company differed from mainstream practice in the way in which they worked within these rehearsal structures. For example, the traditional first day lecture by the director on his/her reading of the play was absent.<sup>59</sup> In its place was a democratic debate guided by Armfield through the given circumstances of the play. Armfield asked the actors to respond to the play on the basis of characterisation, 'style, plot meanings' and 'political background' reminiscent of Italian director Giorgio Strehler's three boxes theory: examining the text from the three levels of family, socio-historical forces and humanist universal notions (Hirst 1991: 32). For Carroll this was one of the strengths of the company: a 'collective understanding' of the text which directly informed the production and which was — in his opinion — why the ensemble's previous production of *Hamlet* had been 'so good.'

Brecht defined collective theatre work as a 'pooling of knowledge' (in Pavis 1998: 63). The first week spent by the company in reading, questioning and debating the text did result in a shared knowledge of the play. However, as with Brecht, one cannot underestimate the vision and personality of the director and their reason for wanting to do the play impacting upon the rehearsal process. The first day of discussion for example, was chaired by Armfield who set the parameters within which debate with the actors would be encouraged, while at the same time actively leading and participating himself. This, it would seem, is where Armfield differs with Cramphorn, in that he is quicker to offer an opinion where the latter was traditionally 'unwilling to assert himself overtly' (Minchinton 1998: 131). However, this may also be a reflection of the shorter rehearsal period that Armfield worked within, forcing quicker decision making. The two directors show a similar approach in Armfield's instruction for the company to run through the entire play at the end of the first

---

<sup>59</sup> Brook has also abandoned 'the first day ... speech' approach which he now sees as a 'rotten way of starting' and prefers a

rehearsal ... climate in which the actors feel free to produce everthing they can bring to the play. That's why in the early stages of rehearsal everything is open and I impose nothing. (1988: 3)

week where he, like Cramphorn, did 'simply ... watch and listen as the actors worked' (1998: 131). Peter Carroll, after reading the description of this run in this thesis, commented that the:

run of the play in its entirety ... is very scary — but provides an instinctual response to form from each actor; and enables the director (I imagine) to perceive a possible overall form. This is a long way, away from an approach in which the director's view of the play and of the characters is imposed. (Appendix 11.3.)

This approach also differs from mainstream practice in that a full run of the play is usually only begun towards the end of the rehearsal, when all the scenes have been blocked by the director and actors, and which serves as a finalising function in molding form, rather than actively originating form, as was the case here. Armfield himself has commented that this early run of the play can be a 'very liberating experience and the actors just work with whatever they're got, with each other, in a space' (in Golder and Madelaine 1994: 79). This seems for Armfield to be a way of reducing theatre to what is for him, its bare essentials: actors telling a story in a particular space with their understanding of the play, their imaginations and their bodies and voices. Carroll supports this apparent empowerment by Armfield of the actors in rehearsal commenting that Armfield

belongs to that small band of directors who allow the actors to create the form and feel in control of their choices. (Appendix 11.3.)

This 'band,' according to Carroll, also includes Lindy Davies<sup>60</sup> who, like Rex Cramphorn, prefers to delay decision making in rehearsal as long as possible. Both Carroll and the stage manager Karen Rodgers talked about how Armfield 'hated' conceptualising and fixing the blocking too early, preferring to allow possible change and development in thinking and blocking up until the last moment. For Carroll what made Armfield's approach a 'different way of working' to that usually encountered within the Sydney Theatre Company was Armfield's resistance 'to the need to see the form fast and then fiddle' mentality (recent telephone

---

<sup>60</sup> Davies' rehearsal 'process requires a longer period than economics presently allow' (in Fewster 1994: 54). Her productions often only have one or two complete run throughs very late in the rehearsal process and immediately prior to performance.

conversation with author). In Benedetti's words, the ability to

cope with the enormous pressure, frustration, and anxiety which accompanies any creative endeavour and which may tempt us to short circuit the creative process for ourselves and for others. (1985: 7)

An actor who worked with Cramphorn expressed a similar sentiment commenting that in

working with large semi-commercial companies ... there isn't this notion of *finding* [my italics] something, there's a notion of getting it as quickly as you can and polishing that version. (in Minchinton 1998: 139)

Mark Minchinton argues that 'majoritarian theatre' and its 'strictly organised timetables militates against the actor ... or director ... organically' using rehearsal time, tending to result in time being 'divided mechanically' like other 'post-industrial machines' (1988: 139). According to Peter Carroll, in spite of only five weeks of rehearsal 'working with Neil' still meant that 'everything [was] investigated in an unhurried fashion', with a sense of timelessness and which in turn created on stage an 'unhurried hypnotic quality' (Recent telephone conversation with author). To achieve this 'quality' Armfield often mirrored the approach taken in the early run of the play with the individual blocking of scenes by usually asking the actors to run the scene first themselves to see, in Carroll's words 'what interesting instinctual things could be pulled out of' the actor (Recent telephone conversation with author). He would then intervene and work in a more conventional manner, alternatively accepting or rejecting the actors' suggestions while making his own — the latter often small but significant visual or aural blocking directions that shaped character and character interaction or relationships. Carroll summed up this approach explaining that:

Neil will have his views no doubt but he cunningly conceals them so that we think we have done it ourselves.  
(Appendix 11.3.)

Armfield actively sought through the reading, discussion, first run and blocking of the play both intellectual and instinctual responses from the actor that he and the actors could subsequently work from — a shared ground that the performance text could spring from. Russell Kiefel offered his own

observations on Armfield's approach after reading Chapter 6 of this thesis, commenting that:

It is clear from your chapter that a hell of a lot of time was spent in this scene getting the starting point right. It seems that Neil subscribes here to the view that if you get that right the rest will flow on from there. (Appendix 11.4.)

Armfield did spend considerable time over where to place the table and the actors at the beginning of scenes — exploring both his own and the actors' suggestions and often changing his mind frequently in determining how to start a scene. He arguably explored the blocking possibilities within scenes as much as he could within the time limits of the rehearsal and stamina of the cast. His technical rehearsal reflected this approach and was a radical alternative to the traditional approach. Armfield said at the time that he had rejected working from 'the old way' of lighting from cue to cue, preferring to work 'through' the whole play 'slowly' and it is from this 'experience', that the play would be 'lit', from 'within', rather than being something imposed upon the production (in Stewart 1996). Such a process sometimes included reworking parts of scenes or whole scenes as Armfield thought required. This was in fact a kind of re-rehearsal of the play to specifically accommodate not only the new elements of light and sound but any late changes in thought over existing blocking of scenes — a partial return to the 'opening phase' of rehearsal by Armfield with its 'freedom to try anything' (Aaron 1986: 24-25). According to Armfield it was an opportunity for the actors to now 'play' with 'all the ingredients' of the theatre event — these 'ingredients' included the set, lighting, sound and the actors themselves, who now knew, 'who they', their characters were and who were now 'finally in their ... costumes' (in Stewart 1996: 16). It was in order to facilitate this sense of play with all these 'ingredients' that Armfield extended the 'tech' way beyond the normal boundaries enabling the time to fully exploit them. According to Armfield allowing this extra time with all these components of 'the physical piece of theatre coming together' would enable the theatre event in its entirety to 'bloom' and 'give out energy' that the audience would be given 'insight' and 'warmed by' (in Stewart 1996: 16).

### 8.3. Strategies for a 'Creative State'

Armfield's strategy of delaying decision making whilst encouraging the actors and himself to actively discuss and debate the text, to continually question and explore the blocking and then to 'play' with the technical resources of the theatre did seem to extend elements of the opening phase of rehearsal throughout the entire rehearsal period. The 'opening phase director' is distinguished by director and clinical psychologist Stephen Aaron as

reviving pleasurable memories from the actor's own childhood when he could joyfully and fearlessly play in front of mother. (1992: 50)

Aaron contrasts this phase with the middle and final phases of rehearsal where the director gradually recedes further away from the actor as staging is set and the director interrupts less. Armfield's approach would seem to be to give actors guiding structures within which they could 'play' right up until opening night. In this respect the analogy of Armfield the director as parent facilitating the child-like play of the actors is most apt. The notion of director as parent, as either mother or father is highlighted by Letzler Cole as one of many 'provisional metaphors' that have been 'substantiated by theatre practitioners themselves' (1992: 4-5). It is the 'maternal gaze ... the mutual gaze of mother and infant' that Letzler Cole sees as

most promising though insufficient to encompass the whole of the director-actor experience. (1992: 5)

Letzler Cole quotes Ann Kaplan who imagines

a male and female gaze ... that would go beyond ... gender duality, into an unconscious delight in mutual gazing.

This 'delight' a 'sort of dance that precedes speech with specific action and reaction going on all the time,'<sup>61</sup> mirrors the nurturing environment that Armfield fostered in the rehearsal room. Armfield in rehearsal would alternatively, stand very still, listening to the actor, or be playfully skipping and skating to and

---

<sup>61</sup> Daniel Stern an experimental psychiatrist 'whose films of infants in interaction with their mothers have profoundly affected the director Robert Wilson' comments that 'mothers and children play all sorts of exaggerated verbal-visual games' (in Aaron 1992: 229).

fro between the actors and his chair. He would allow two of the actors and the assistant director to throw a tennis ball behind his back, while seemingly not noticing. He would also allow a noise level uncommon in mainstream rehearsal, and permit jokes and repartee between the actors to flourish — all part of what Armfield himself sees as being 'as relaxed as possible in rehearsal' and creating a 'work atmosphere in which you feel anyone can say what they think' (in Stewart 1996). These aspects of his approach ensured an atmosphere of trust, play, pleasure and fun where Armfield allowed a certain amount of licentiousness, a child-like quality of anarchic play that he facilitated in the rehearsal room. In the actor Simon Callow's words, an 'amniotic fluid in which creativity can flourish' and which as 'the director's job in all this is parental' he must create (1984: 174). In a recent feature article in the *Weekend Australian*, Armfield was described as being 'famous for the unique sense of play he brings to his work' (Cosic 1999: 20). It is evident in rehearsing the *Blind Giant* that he actively encouraged the actors to play, laugh and 'muck around' a lot more than actors such as Hugo Weaving were accustomed to in mainstream practice. Weaving like other actors within the ensemble, loved this freedom to play and arguably found it liberating and a release of the 'energy' that Armfield wanted them to 'give out' to the audience (in Stewart 1996). For Benedetti the

most common failing of directors [is] that they impede rather than liberate the energies of their fellow artists. (1985: 4)

In his survey of thirty directors and their work processes in the USA he found certain recurrent responses that included:

"sharing, collaboration, commitment, creative energy" and "flow" ... [that] express a kind of energy that is uninhibited and unselfish. (1985: 4)

According to Benedetti what is wanted by the director in the 'rehearsal hall' is a 'creative state ... in which the play will grow.' This 'creative state' will reflect the director's own 'mood' and 'implies a spirit of enthusiasm and almost child-like abandon' and therefore to be 'effective' the director tends to be 'that difficult blending of child and adult necessary to artists' (1985: 7). Armfield's actions in rehearsal would often seem to embody this blend of child and adult who would allow play while defining the boundaries.

An integral part of fostering this sense of play was Armfield's propensity to allow actors to make mistakes without coming down hard on them. This approach from a director is held up by actors such as Kerry Walker as the keystone to allowing her creative energy to flourish. This ability in the director to allow actors to make mistakes as they search for the right option seems to be important in establishing a collaborative and democratic atmosphere in the rehearsal room — in theatre talk, giving actors room. A view articulated not only by Walker but many of the directors that Benedetti surveyed and by such influential acting teachers as Phillippe Gaulier.<sup>62</sup> The actor Susan Lyons has commented that:

If you use the metaphor of growing up in rehearsal ... you want a really good parent who's going to give you enough space to make mistakes, to make a fool of yourself, to fall over and be there to pick you up. (Quoted from *Old Times* workshop Performance Studies 1995)

Similarly Simon Callow sees the process of acting as primarily 'giving birth' to a character and in rehearsal

what we are engaged in is deeply and seriously childish ... like all children's games it is exploratory: trying out, trying on, investigating .... play tests things out. (1984: 178)

For Callow the difficult challenge for the actor is to find this 'child-self [which] is behind all great acting' (1984: 175). This is what he feels is the 'whole' point of rehearsal and which is 'hard for some directors, as for some parents ... to give the actor-child his freedom and independence.' According to Callow the guiding boundaries of rehearsal are the questions the director 'must ask', and the praise and criticism he must give to aid the actor in 'crystallizing [and] elucidating' their character (1984: 175).

The model of director as parent for Armfield finds support in what Armfield, himself found so 'exhilarating' about the Company B ensemble in 1995: a 'family of great actors moving from show to show, growing and developing together' under his direction (1996: 7). The 'family' metaphor for a company of actors

---

<sup>62</sup> In the International Workshop Festival in Adelaide in 1995 Gaulier articulated during improvisational exercises the importance to the actor of making mistakes in order to find the right answer. In his words, 'Monsieur Flop' is your friend and guide to what you are seeking as an actor. American Director Michael Leibert has commented similarly that: 'actors need to make mistakes on their own, or their own understanding would never be truthful' (in Benedetti 1985: 6).

and which includes the importance of 'play' has also been used to describe the work of the celebrated British-based Theatre de Complicite ensemble by both critics and company members themselves.<sup>63</sup> This ensemble for example has been defined by British journalist Lyn Gardner as a 'family that plays together and [subsequently] stays together' and which like 'all close families may fall out but there is an irresistible tug' which according to designer Paula Considine makes 'you feel part of something more than just a theatre company' (in Gardner 1997: 26). Gardner states that what 'characterises' Complicite's work is the 'sense of play' while Considine describes the company members, themselves as 'intensely childlike' and with a 'rare integrity' (1997: 26). Founding company member Annabel Arden has said that 'it is people [rather than an emphasis on product] which provides the bricks and mortar of the company' (1997: 26). Arden comments that the company members 'have been bound to each other because the shared understanding really is shared' (1997: 26) which directly echoes Peter Carroll's own comment that what made the Company B ensemble's work 'so good' was their own sense of 'shared understanding' of the text. Michael Ratcliffe in turn has said of Complicite that 'without the commitment of each actor to his colleagues the company, *family* [my italics] and team would cease to be' (1995). With the dissolution of the Company B ensemble Armfield has since still defined the importance of this sense of 'family' to his own work, commenting:

that what theatre is (for me) is a series of families  
that you set up and you live within and you try to look after  
the people you're working with. (in Larkin 1996: 12)

Armfield's use of a 'family' model for not only the company B ensemble but all the people he works with probably reflects his own sense of being 'grounded in his closeness to his family' (Cosic 1999: 23). A number of commentators have remarked on the importance of a family-like atmosphere in Armfield's work, which stems from his real life family.<sup>64</sup> It is interesting to note

---

<sup>63</sup> Theatre de Complicite has according to Lyn Gardner 'changed British culture beyond all recognition' by combining a collective 'virtuoso technique with a sense of humour, laughter, impending sense of doom, cruelty' which is led by the 'singular vision' of its director Simon McBurney (1997: 26). According to Michael Ratcliffe, it is a collective that 'devises its own shows around a universal theme ... [or] text — through months of argument, rehearsal and research' (1995).

<sup>64</sup> For example John Larkin comments that Armfield's 'sense of family is much extended. It ranges from his own childhood household ... to the ensemble of talented actors with whom he works' and which 'brings an intimacy into' his theatre productions (1996: 12).

that Armfield's description of his childhood seems to illuminate his directing philosophy:

You certainly watch and you learn to make yourself heard or felt, sometimes in the most devious of ways. You have no alternative — either you're the clown or you're the silent witness who lets everyone commit to something and then decides on your own position. (in Cosic 1999: 22)

Armfield has also described how he 'gets all the cast working at the same emotional intensity' through a parental-like 'patience ... working at what's not working until it does work, calmly, reassuringly' (in Litson 1995: 80). Peter Carroll describes this as

another blessed feature of Neil's direction ... his (seemingly) unhurried attention to detail. [where] Everything is explored and given value [resulting in] productions [that] are epic, through a sequence of minutely observed moments. (Appendix 11.3.)

However, how Armfield achieved this 'attention to detail' within such a short rehearsal time on the *Blind Giant*, reflected very much the controlling side of the director as parent model. While creating an unhurried democratic atmosphere where various interpretative options could be explored, Armfield's visual and aural blocking of the actors was often autocratic. After directing the actors to run the scenes first by themselves, he would then usually give them extremely precise instructions as he blocked the scene. Louis Nowra's definition of Armfield as a 'fascist for detail' reflects this approach. In order to achieve as Carroll states such 'minutely observed moments' Armfield gave very specific directions in where to move, how to move and what inflection to give certain lines that risked 'emasculating the actor' (1998 Pavis: 103). Such line-readings have traditionally been regarded as restricting and inhibiting for the actor. However as Pavis points out when a director of the calibre of a Giorgio Strehler

shows the actor what is expected ... it is always a show in itself, [and] an invitation to go beyond imitation, and a blessing for the actor. (1998: 103)

Simon Callow (in what could be an analogy for how the actor deals with being shown what to do by the director) traces the actor in rehearsal back to

the child [who] imitates his mother in order to understand her to be able to deal with her, to take away some of her magic. (1984: 178)

This is where Armfield's 'magic' as a director differs markedly from that of Cramphorn in that he gives actors precise instructions, or commits regular 'acts of violence' in Anne Bogart's words. As one actor who worked with Cramphorn commented:

If you wanted a director to be father and you to be child, or him master and you servant, you were fucked. Rex could only work on an equal basis. You couldn't expect him to tell you what to do, or to trust that he was going to have it all ready on time if you just did what he said. (in Minchinton 1998: 143)

On the other hand Miriam Cosic has argued that it is Armfield's:

blend of experimentation and fun, coupled with his intellectual rigour, which allows actors to plumb their depths, without fear of seeming silly or pretentious or of being allowed to go on stage in front of the paying public and make fools of themselves. (1999: 20)

Actors accustomed to mainstream rehearsal process who have worked with the 'most democratic of directors' like the Englishman Bill Alexander and Cramphorn, have often complained about their lack of decision making when in their view it is desperately required.<sup>65</sup> Importantly, it is perhaps this quality of decision making, a benign autocracy in Armfield's case, that allows such actors as Walker to have confidence in the director's process where in their view open-endedness is balanced with an outside, critical, observing eye. If as Aaron argues the 'director

---

<sup>65</sup> The actor Anthony Sher, during the rehearsal of *Richard III*, laments that director Bill Alexander doesn't 'decide' when he 'should' between the different 'solutions to the problems in these scenes [but] sits silently, looking miserable ... and continues to sit obstinately on the fence, so it's left unresolved' (1985: 211). James Waites comments that several actors who worked with Cramphorn in 1980 on two Shakespeare texts, felt that 'problems existed ... in our democratic approach ... decisions took too long ... [and believed] Rex was falling down on the job' (in Fotheringham 1987: 185).

functions as the actor's observing ego' during rehearsal, then it is critical that the actor has faith in the director to be a 'reliable mirror', who is able to see and evaluate what the actor can't see, the overall stage picture (1986: 116 & 44). Lindy Davies defines the director's role as being responsible for such an overall 'aesthetic' that the individual actor does not always necessarily see, because they are inside a scene rather than outside it, looking in; it is the director who must look at the 'function of a scene' and not be 'ruled by the personality of the actor' (In Fewster 1994: 17). The English director Declan Donellan has expressed a similar view:

An actor can't say to me, "I don't see how this fits in so I won't do it" because he can't see my overall concept.  
(in Cook 1983: 92-93)

Simon Callow also supports this notion from an actor's viewpoint commenting that:

narrative, meaning and style must be insisted on by someone who is not you [but by the director] ... It's almost impossible for you, thrashing around in the filthy waters of your subconscious, to maintain an over-view of the play.  
(1984: 174)

[and] The director has to develop an acute sense of the graph of your performance ... Because it's going on inside you, you can be cruelly deceived by what you're feeling as opposed to what you're doing. (1984: 175)

Armfield himself almost apologised during the rehearsal of the *Blind Giant* when he explained that in giving direction to the actors, by telling them what to do was not something 'you want to do' but have to do in your role as director. Walker rather reluctantly admitted such a faith in Armfield's direction when she commented that when she first started working with Armfield she had initially fought against his blocking decisions but now accepted them as being 'right.'

Walker's working relationship with Armfield is fascinating for its tension, drawn from the opposition between the faith they have in each other and the determination of both to explore their own creative 'options' in a play. This tension often manifested itself in Walker's sardonic humour that seemed to indicate that Armfield was as fallible as anyone. Aaron has talked about how actors will sometimes 'deny' their dependence on the director by

publicly undermining or 'obliterating' their function while privately praising them (1986; 219-21, 42). Walker's comments reflected this: gently mocking Armfield while nonetheless expressing a need for his support and guidance — none more poignant than her comment that they couldn't 'do anything without a director' said in Armfield's absence and immediately before the first run of the play, in week one, when the actors would be very much in control, though still needing Armfield's presence and guiding boundaries to begin with. Walker's relationship with Armfield is in Foucault's analysis of power:

less of a face-to-face confrontation which paralyses both sides than a permanent provocation.  
(in Wallis 1984: 428)

The 'power relationship' between Armfield and Walker was constantly provoked by the 'recalcitrance of the will' of the director and the 'intransigence' of the actor's search for 'freedom' to make their own choices in rehearsal (in Wallis 1984: 428). In Walker's own words, this translates as Armfield's ability to surround

himself with actors who challenge him yet the results are always so unmistakably his. (Appendix 11.5.)

and which is very much dependent upon Armfield's personal sense of security as a director — an artistic ego that is not threatened when challenged by the actors he works with. Peter Carroll has echoed this thought, commenting that it is Armfield's 'non-judgemental [and] ego-less' approach that indeed 'empowers the actor' in rehearsal and subsequently in performance (Recent telephone conversation with the author).

Kiefel's relationship with Armfield is more problematic. Kiefel said to me recently that while the *Blind Giant* was for him 'a bit of a hit', the following production with Armfield, *The Alchemist* was less so and he has not worked with Armfield since (Recent telephone conversation with author). Even in the *Blind Giant* Kiefel felt a 'frustration' where he thought Armfield

was continually holding me up like a rider reining in a horse, whereas other actors seemed to have more freedom to explore and discover. (Appendix 11.4.)

To be fair though, Kiefel immediately follows this thought with the proviso that he has a

To be fair though, Kiefel immediately follows this thought with the proviso that he has a

tendency ... to generalise, an impatience to move forward ... and Neil would (probably quite deliberately) slow me down to get some detail into the thing. (Appendix 11.4.)

It is clear though that Armfield gave a great deal of business not only to Kiefel, but to Walker, Clarke and other actors as well. Kiefel interestingly had no memory of the 'voice stuff at all' and thought that the description in chapter 6 of this thesis of Armfield's 'process' of developing a 'Richo-inspired' voice for Kiefel's character, Michael Wells was 'very imposed — not organic at all — not the way I like to work' (Appendix 11.4.). It would seem that Armfield 'imposed' much more on both Kiefel and Clarke in developing their character's voice. The motive for this would appear to be Armfield's sense that these two actors needed stronger direction or guidance — particularly Clarke who was a newcomer to the company and often seemed at odds with Armfield on the interpretation of his character Bruce. One returns to Davies' view of the overall aesthetic as a validation for such an imposition by Armfield or in Armfield's own words fulfilling his 'duty' as a director by doing his 'job' and 'giving direction'. Seeing this power the director has in rehearsal to shape an actor's performance from a Foucaultian perspective clarifies this process in that:

the relationship of power can be the result of a prior or permanent consent, but it is not by nature the manifestation of a consensus. (in Wallis 1984: 427)

That is, that while the company prior to rehearsal may be organised on democratic lines, decisions taken within rehearsal may not necessarily be democratic, or reached by 'consensus.' Declan Donellan expresses a similar view stating that the:

"Director" has become a dirty word in theatre and that's wrong. I don't want a democratic relationship with the nurse and the anaesthetist and the surgeon who has to give me a brain operation. I want the hospital run on democratic lines as to who is employed and conditions and so on, but I don't want a collective decision made as to who operates on me or the operation carried out by a collective.

[and theatre] doesn't work without someone being in the overall charge, giving a sense of an overall whole. It shows in the productions which have no overall concept and no sense of the actors all working together.  
(in Cook 1987: 92-93)

Catherine McClements description of Armfield as a 'democratic fascist' neatly combines the two principal oppositional forces in rehearsal that need to be reconciled: the actors desire for

a lot of freedom ... to make my own mistakes [where] what is right is defined by what is experienced that is not right. (Actor Fiona Press from *Old Times* workshop Performance Studies 1995).

and their need to be 'pushed' by the director when in a 'I'm stuck. Can't you see?' mode (Actor Susan Lyons from *Old Times* workshop Performance Studies 1995). From a director's point of view Robert Lepage has expressed this similarly, commenting that:

You have to let the show take shape on its own, let the meaning emerge freely ... [but] sometimes freeing the meaning can also involve constraining the actors with very precise instructions. (in Charest 1996: 136)

The latter he freely admits to being 'contradictory' and he expresses a fascination for 'this paradoxical relationship between freedom and constraint' which his 'work on the *Tempest* revealed time and again.'<sup>66</sup> In this respect 'the search for a less alienating theatre process is endless and always improvisational' (Fortier 1997: 9) — very much dependent upon the personalities of the director and actors within the larger context of the 'political organisation' of the theatre company which dictates what theatre event will be produced, who will produce it and the time available

---

<sup>66</sup> Inspired by Brook's *Tempest* which took 'freedom' as the theme of the play and where Brook 'set his production on an empty stage with virtually no props', Lepage set the 'play in a rehearsal space where the actors would read the text and improvise scenes' — the idea being that each performance would be different, thus freeing the actor. But just the opposite occurred: a 'hellish nightmare' where 'nothing worked.' The actors didn't improve from performance to performance and 'constantly' asked for Lepage to 'block them, to give them precise directions.' Initially he refused telling them to 'let themselves go' as they could do it in rehearsal, why not in performance? Lepage concludes that the concept was only finally 'validated' when 'we stopped improvising' and 'final irrevocable decisions were made' (in Charest 1995: 136-137).

for rehearsal. According to Mark Fortier to

struggle for a more humane ... more democratic process in theatre production is to search for an unsustainable ideal ... as what seemed democratic in one situation from one point of view may not seem so in another situation or to other viewpoints ... all that can happen is an endless retooling that is never perfected. (1997: 9)

In theatre rehearsal how much the needs of the individual actors are met is largely determined by the actions of the director and whether that director is autocratic, democratic or somewhere between the two. Autocracy limits an actor's 'options' and 'inhibits' their actions according to Kerry Walker. Democracy promises a shared ideal, according to Armfield, the 'sum of which is greater than its parts' (1995), and according to Minchinton writing on Cramphorn:

meaning that is richer for being allowed to emerge by the director from a multiplicity of viewpoints or voices rather than generated from a single masterful viewpoint or authorial inscription by writer or director. (1998: 134-135)

There is no doubt that in addition to having the time to allow the director and actors to genuinely explore the text in rehearsal, democracy in rehearsal process is facilitated by a group that is relatively stable. In Stephen Sewell's words a group's 'commonality of purpose' can only be achieved through a working knowledge and 'trust' of each other, gained over time — a group who will subsequently not be threatened by debate, but allow it (in Ridgman 1983: 108). An ensemble gives a structure that facilitates exploration, because everyone knows each other, how they work and their 'ambitions and motivations' (1983: 108). James Waites described the success of two Shakespeare productions<sup>67</sup> directed by Rex Cramphorn as due to:

The advantage of having a group familiar with each other's ways ... a spirit of creative unity was in the air, and many of the best ideas came, as if out of nowhere. (1987: 188)

---

<sup>67</sup> In 1985 Cramphorn directed the productions of *Hamlet* and *Measure for Measure* at the Playbox Theatre in Melbourne, as part of what was termed an 'Actors' Development Stream' which aimed to 'research ... performance ... especially ... classics (Waites 1987: 186). These productions grew out of an Australia Council-funded research project that had explored democracy in rehearsal five years earlier. Interestingly enough Kerry Walker was one of the actors in this original group.

According to Armfield on the first day of rehearsing the *Blind Giant* it was because they all knew 'each other' that they would be able to 'work faster than normal.' For Simon Callow normally it is only after

weeks go by that the initially disparate group of people thrown together to put the play on become close ... a ... family ... trusting and therefore free to be rough with each other ... to put ourselves on the line. (1984: 177)

It is only then that 'barriers collapse' and the actors can be 'brave' enough to be 'childish' to find a sense of family, of ensemble — a social gestus that facilitates creativity (Callow 1984: 177). Sewell has said of his experience with the Lighthouse Theatre ensemble that it was only with a close and constant 'working relationship' that he could determine the 'aesthetic ... direction that is needed' (in Ridgman 1983: 108). Peter Hall has commented similarly that

you can't work well in the theatre without a sense of ensemble. And that means knowing each other and knowing what you respect in each other and indeed knowing what you dislike in each other as artistes. (in Miles 1991: 206)

That the Company B ensemble was unable to be maintained is less of a reflection on its artistic success and more a reflection on the nature of the actor as 'product' as David Farr artistic director of the alternative Gate theatre in Notting Hill, London comments:

I think it's very difficult these days to get a communality going in any form of life. Everything is so transitory. Actors are like products, they move around and it's very hard to hold anyone down. (in Farr 1997: 65-66)

Peter Carroll has commented similarly that the:

failure of the ensemble was due to financial pressure — if you could be employed for a year, it would be a different matter. (Recent telephone conversation with the author)

Armfield's 'procrastination', the patience to wait for the 'right thing to emerge' in rehearsal and his propensity to 'consider everything very, very carefully' means he has taken 'the boundaries as far as he can take them' within the time demands of

mainstream rehearsal practice (Cosic 1999: 23).<sup>68</sup> He also continues to partially subvert mainstream rehearsal work by working within, in his words, 'a series of families' that includes Company B and where in the absence of an ongoing ensemble he creates an ensemble-like atmosphere by working regularly with actors familiar with his methods. This atmosphere that encourages both a 'shared understanding' of the play by the actors involved and a sense of play can be seen as oppositional to the machine-like demands of much of contemporary, commercial theatre practice. Armfield's methodology as a director would seem to be more autocratic than that of a radical democrat like Cramphorn but more democratic than the State Theatre Company system allows. He will no doubt continue to push the boundaries as far as they can go within an Australian text-based theatre culture that is under-funded, under-resourced and forced by commercial pressures into regularly producing theatre product in limited time.







---

<sup>68</sup> Mary Vallentine a colleague of Armfield's at The State Theatre Company of SA comments that Armfield's method of 'leaving rehearsals so open-ended' used to drive her 'fucking crazy! ... [However] his work in opera which has to be planned 18 months ahead of the premiere shows he can be disciplined if he needs to be' (in Cosic 1999: 23). Though it seems clear that the latter is not his preferred method.

**Appendix 1.**  
**State Theatre Company of SA Production Schedule**

# PRODUCTION SCHEDULE

## Countdown to Opening Night

Time Scale	Procedure	Responsibility
<b>6 Months</b>	<p>SELECTION OF THE SCRIPT                      THE SELECTION OF THE DIRECTOR, DESIGNER(S) AND THE LIGHTING DESIGNER                      Director and Designer(s) decide on style of the production etc.</p>	<p>Administration, Management, Box Office — Promotions, etc.                      Director and Designers</p> 
<b>20 Weeks</b>	<p>ACTOR'S AUDITION                      INTENSIVE WORK ON THE SCRIPT BY THE DIRECTOR DESIGNER AND DIRECTOR discuss first costume sketches and model ideas                      DESIGN CONCEPT FINALISED. Final set model and Costumes designed.</p>	 
<b>12 Weeks</b>	<p>DESIGNS PRESENTED, COSTED AND SAMPLED                      All fabrics and construction materials are purchased, ready for manufacture.                      FIRST PRODUCTION MEETING.</p>	<p>Production Manager and Department Heads</p> 
<b>7 Weeks</b>	<p>Work begins on building the Sets, making or finding the props and making the Costumes</p> 	<p>Scenery Workshop                      Scene Painters                      Properties                      Wardrobe, Millinery, Wigs</p>
<b>6 Weeks</b>	<p>REHEARSALS COMMENCE. The first Reading with the entire company                      Scenes are discussed between the actors and the director.                      The play is blocked. Scene rehearsals commence                      Actors have learned all their lines                      LIGHTING DESIGN FINALISED                      Costumes worn in rehearsal</p> 	<p>Actors                      Stage Management                      Publicity</p> 
<b>1 Week</b>	<p>PRODUCTION WEEK. Bump in to the Theatre                      First Preview</p>	

**OPENING NIGHT**  
**The Run of the Play**

**Appendix 2.**  
**Company B Rehearsal and Production Schedules**

THE BLIND GIANT IS DANCING

REHEARSAL SCHEDULE                      WEEK 1

MONDAY JULY 10

10.00am - 1.00pm	First Reading	Full Company
1.00pm - 2.00pm	Lunch	
2.00pm - 6.00pm	Script Work	Full Company

NB. Today's rehearsal will take place at Belvior Street Theatre.

---

TUESDAY JULY 11

10.00am-11.00am	Design Presentation	Full Company Minus Mr Koman, Mr Cotterill
11.00am - 6pm	Script analysis	As Above

---

WEDNESDAY JULY 12

10.00am - 6.00pm	Script analysis	Full Company
4.30pm	Publicity Call	Mr Koman

---

THURSDAY JULY 13

10.00am - 6.00pm	Script analysis	Full Company
------------------	-----------------	--------------

---

FRIDAY JULY 14

10.00am - 6.00pm	Script analysis	Full Company minus Mr Kieffel
------------------	-----------------	----------------------------------

---

THE BLIND GIANT IS DANCING  
REHEARSAL SCHEDULE                      WEEK 2

MONDAY JULY 17

10.00am - 1.00pm	Script Analysis	Full Company
1.00pm - 2.00pm	Lunch	
2.00pm - 6.30pm	Run Play	Full Company

---

TUESDAY JULY 18

10.00am-12.00pm	Act 1. Scene 4 Pg. 6 - 13	Mr Weaving Ms McClements
12.00pm - 1.00pm	Act 1. Scene 5 Pg. 13 - 14	Ms McClements Ms Jones
2.00pm - 5.00pm	Act 1. Scene 3 Pg. 5 - 6	Full Company minus Mr Kiefel
5.00pm - 6pm	Act 1. Scene 1 Pg. 3	Mr Clarke Mr Cotterill

---

WEDNESDAY JULY 19

10.00am - 1.00pm	Act 1. Scene 6 Pg. 15 - 21	Mr Weaving Ms Blanchett Ms Jones Mr Smith
Noon	Pg. 22 - 25	Mr Kiefel to join
2.00pm - 6.00pm	Act 1. Scene 6 Pg. 15 - 25	Full Company minus Mr Koman and Mr Cotterill

---

THURSDAY JULY 20

10.00am - 1.00pm	Act 1. Scene 7 Pg. 26 - 30	Mr Weaving Mr Koman
2.00pm - 6.00pm	Act 1. Scene 8 + Scene 4 Pg. 31 - 35 + pg.6 - 13	Mr Weaving Ms McClements

---

FRIDAY JULY 21

10.00am - 11.30am	Act 1. Scene 2 Pg. 4 - 5	Mr Kiefel Mr Robinson
11.00am - 1.00pm	Act 1. Scene 9 Pg. 35 - 36	Mr Kiefel Mr Smith
2.00pm - 4.00pm	Act 1. Scene 10 Act 1. Scene 11 Pg. 37 - 38	Full Company
4.00pm - 6.00pm	Run Act 1	Full Company

---

**THE BLIND GIANT IS DANCING**  
**REHEARSAL SCHEDULE - WEEK 3**

**N.B. We will be starting at 9am this week.**

**Monday 24th July**

9.00am - 1.00pm	Act 2. Sc. 5 Pg. 50 - 56	Mr Weaving, Ms Blanchett
2.00pm - 5.30pm	Act 2. Sc. 7. Act 2. Sc. 8. Act 2. Sc. 9. Pg. 56 - 59	Mr Clarke, Mr Weaving, Ms McClements, Mr Carroll, Ms Walker.

---

**Tuesday 25th July**

9.00am - 1.00pm	Act 2. Sc. 1. Pg. 39 - 44 Act 2. Sc. 16	Mr Kiefel, Mr Robinson, Mr Cotterill
Noon		Ms Jones to join
10.00am - 1.00pm	Shopping with Edie	Mr Weaving
2.00pm - 4.30pm	Act 2. Sc. 4. Pg. 49 - 50	Full Company minus Mr Weaving & Ms Blanchett
4.30pm - 6.00pm	RUN ACT 1.	Full Company

---

**Wednesday 27th July**

9am - 1.00pm	Act 2. Sc.7 Act 2. Sc. 8 Act 2. Sc. 9. Act 2. Sc. 13.	Mr Clarke, Mr Weaving, Ms McClements, Mr Carroll, Ms Walker.
2.00pm - 5.30pm	Act 2. Sc. 6 Pg. 56 Act 2. Sc 10 Pg. 69 - 72	Mr Weaving, Ms McClements,
6.00pm	Production Meeting at Belvoir Street	

**Thursday 28th July**

9am - 11.30pm	Act 2. Sc 3. Pg. 47 - 48	Mr Robinson, Mr Weaving, Ms Blanchett
11.30 pm - 1.00pm	Act 2. Sc 12. Pg. 74 - 76 Act 2. Sc 14. Pg. 77	Mr Robinson, Mr Weaving, Mr Koman
2.00pm - 6.00pm	Act 2. Sc 2. Pg. 45 - 46 Act 2. Sc 11 Pg. 72 - 73	Ms McClements, Ms Jones

---

**Friday 28th July**

9.00am - 1.00pm	Act 2. Sc. 17 Pg. 78 - 80 Act 2. Sc. 5 Pg. 50 - 56	Mr Weaving, Ms Blanchett
2.00pm - 3.00pm	Act 2. Sc. 15 Pg. 78	Ms Jones, Mr Rodgers
3.00pm - 5.30pm	Act 1. Sc. 6 (party scene)	Full Company minus Mr Kiefel

---

**Saturday 29th July**

10.30am - 12.30pm	RUN ACT 2	Full Company
-------------------	-----------	--------------

**"Blind Giant" Rehearsal Schedule Week 4**

<b>Monday July 31</b>		
9am - 1pm	3.1 (pg 81-86)	Mr Weaving, Mr Kiefel
2pm - 6pm	3.4 & 3.5 (pg 89-93) 3.7 (pg 94)	Mr Weaving, Ms Blanchett
6.30pm - 9.30pm	3.10 (pg 99-103)	Mr Clarke, Mr Carroll, Ms Walker
<b>Tuesday August 1</b>		
10.00am - 1.00pm	3.9 (pp95-99)	Mr Weaving, Ms McClements
10.00am - 1.00pm	Shopping with Edie	Ms Blanchett
1.15pm	Mr Weaving Interview with Daily Telegraph (Mr Weary)	
2.00pm-6.00pm	3.3 (pg 88) 3.6 (pg 93) 3.16 (pp 116-117) 3.21 (pp 125-126) 3.23 (pg 126) 3.25 (pg 127)	Full Company (Minus Ms Blanchett, Mr Weaving)
6.30pm-8.00pm	3.13 (pp108-110)	Mr Kiefel, Mr Robinson
<b>Wednesday August 2</b>		
10.00am-11.30am	3.14 (pp 110-112)	Mr Rodgers, Mr Weaving
11.30am-1.00pm	3.27	Mr Kiefel, Mr Weaving
2.00pm-4.00pm	3.29, 3.30 (pp130-132)	Mr Weaving, Ms Blanchett
4.00pm-10.00pm	3.17 (pp 117-123)	Mr Weaving, Mr Clarke
<b>Thursday August 3</b>		
10.00am-1.00pm	3.15 (pp112-116)	Ms McClements, Mr Weaving
2.00pm-6.00pm	3.18, 3.20, 3.22, 3.24, 3.26, 3.28, 3.31, 3.32	Full Company
6.30pm-8.00pm	TBA if Act 3 not complete	
<b>Friday August 4</b>		
10.00am-1.00pm	Run Act 3	Full Company
2.00pm-6.00pm	Run Play	Full Company
<b>Saturday August 5</b>		
TBA		
<b>Monday August 7</b>		
10.00am-1.00pm	Work bits	Full Company
2.00pm-6.00pm	Run in Costume ("Review" to film)	Full Company
<b>Tuesday August 8</b>		
TBA (Production Schedule)		

# BELVOIR ST THEATRE

## PRODUCTION SCHEDULE

### The Blind Giant is Dancing

#### Thursday August 10

Time	Activity	Staff	Notes
9am - 12pm	Scenic art & Lx tidy		As Required
12pm - 1pm	Lunch		
1pm - 2pm	Prepare for TECH	Showstaff	
1.25pm	1/2 hour call		
2pm	Continue TECH	Full Company	
6pm - 7pm	Dinner		Dinner provided
7pm - 11pm	Continue TECH	Showstaff	

#### Friday August 11

Time	Activity	Staff	Notes
9am - 12pm	Lx & Set Tidy		As Required
12pm - 1pm	Prepare for Dress	Showstaff	
1.25pm	1/2 hour call		
2pm	Continue TECH	Full Company	
5.30pm - 7pm	Dinner		
7pm - 8pm	Prepare for DRESS	Showstaff	
7.25pm	1/2 hour call		
8pm	DRESS 1	Full Company	

#### Saturday August 12

9am - 1pm	Set & Lx work as required		
12pm - 1pm	Prepare for DRESS	Showstaff	
12.25pm	1/2 hour call		
1pm	DRESS 2	Full Company	
7pm - 8pm	Prepare for Preview	Showstaff	
7.25pm	1/2 hour call		
8pm	PREVIEW 1	Full Company	

#### Sunday August 13

12pm	Work on stage as required	Full company	TBA
4pm - 5pm	Prepare for Preview	Showstaff	
4.25pm	1/2 hour call		
5pm	PREVIEW 2	Full Company	

#### Tuesday August 15

7pm - 8pm	Prepare for Opening	Showstaff	
7.25pm	1/2 hour call		
8pm	OPENING	Full Company	

**Appendix 3.**  
**Letter From Peter Carroll**

28. 1. 90

Dear Russell,

Your rehearsal notes brought back memories of that fascinating (as all Neil's are!) production. Instinctively, we felt we were dealing with a big, even great, difficult text. The play is, I believe, a most important one. The examination of patriarchal values; the power struggles within the family, (biological & political), and the consequences of this world view on behaviour, is exhaustive. The quality of writing matches the "bigness" of the theme - the rhetoric has a muscular strength which catapults the action - it plays powerfully. I think the writing of the family scenes is particularly fine - certainly a joy for the ~~actor~~ <sup>actor</sup> - so simple, so clear; full of character hints for the actor. This play must rate as one of the finest of its period - I believe it is, and will remain, a classic.

Incidentally, I realize (from your notes) how demanding and insistent I am with a director (once encouraged to be so) and how meticulous & caring Neil's replies are - always.

Neil belongs to that small band of directors ~~who~~ who allow the actors to create the form, & feel in control of their choices. In a sense this process is aided by the permanent structure of the Belvoir acting space which enables or requires the transformation to occur within known limits.

\* The "run" of the play in its entirety, after a brief time of discussion, is very scary - but provides an instinctive response to form from each actor, and enable the director (I imagine) to perceive a possible overall form.

This is a long way away from an approach in which the director's view of the play, and of the character, is imposed. (Neil will have his views no doubt, but he cunningly conceals them so that we think we have done it all ourselves!)

Another blessed feature of Neil's direction is his (seemingly) unhurried attention to detail. Everything is explored and given value. His productions have an hypnotic effect on the watcher - they are epic, through a sequence of minutely observed presentation of moments.

It was a difficult, trying play to perform. But a wonderful challenge, and a ~~lasting~~ now, through your notes, a satisfying memory.

Many thanks -

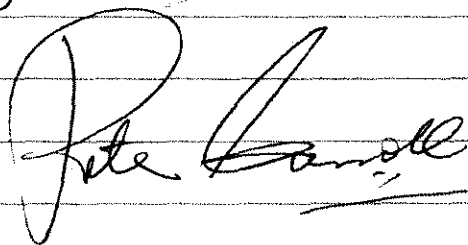

PETER CARROLL

**Appendix 4.**  
**Letter from Russell Kiefel**

6 Bennett St  
Thebarton SA 5031  
Ph. 08 8352 2872

13 Mc Farlane Street  
Northcote  
Vic. 2070  
7/3/00

Dear Russell,

Thanks for letting me read Chapter 6 - "Confrontation by Two," of your thesis. It is certainly an interesting read insofar as my memory of Blind Giant is fairly general and more related to the finished product than your incredibly detailed record.

For instance my memory of it is rather dream like and involves the table moving through shadows and people wearing 80's "period" costumes - superficial things like that. So your account is fascinating to me as an exercise in remembering because, as you can imagine, an actor forgets the stuff that is discarded in rehearsal. In fact many of us are flat out remembering the stuff we need to.

My relationship to this play goes back to 1983 when I played Bruce in the premier production for Lighthouse in Adelaide. And I have always regarded it as one of our great plays. So I was very keen to be involved when I learned that Neil was going to revive it. I've always fancied myself as an Alan but was more than happy to take on Wells when he was offered.

My memory of creating the role of Wells in this production is of choosing to wear a red cardigan and developing the finger walking across the table business. ( which I remember you, as an observer, encouraging - I probably would have lost interest and dropped this piece of business if you hadn't been there. ) Neil's contribution I remember as giving me the dental floss - an outrageous piece of business. And that would probably be my memory of it if I hadn't read your material.

It is a very interesting insight for me into the way my relationship with Neil worked on the rehearsal room floor. I suppose the fact that I come across as a fairly stropky - hard - to - get - along - with - bastard is a measure of the frustration I have sometimes felt working with Neil. It seemed that he was continually holding me up like a rider reining in a horse, whereas other actors seemed to have more freedom to explore and discover. But then I would have to admit a tendency in myself to generalize, an impatience to move forward through the piece and get a sense of the story, and Neil would (probably quite deliberately) slow me down to get some detail into the thing. It is clear from your chapter that a hell of a lot of time was spent in this scene getting the starting point right. It seems that Neil subscribes here to the view that if you get that right the rest will flow on from there.

I don't remember the voice stuff at all - i.e.: finding a suitable voice for Wells. Your description of it sounds like that particular process was very imposed - not organic at all - not the way I like to work.

As for the suggestion of the whisky and glasses, sometimes an actor has to wait and see where a scene is going before he can suggest a particular piece of business that he thought of at home. But it is also gratifying to know that this particular actor's suggestions could be so easily and graciously accommodated by the director. And to further illustrate where a scene can go, I remember the beginning of this scene, after playing in the theatre for a while, being like a showdown between two western gunfighters as we both entered, me upstage walking down to the table and the whisky bottle and Hugo approaching from the downstage entrance, both about to draw imaginary guns.

Anyway Russell, apart from wanting to rewrite some sections of your chapter where I sound like Grumpy the dwarf, I think it's a terrific document of a very important production in the history of Australian theatre. It would be interesting to hear how a non participant responds to it. Good luck with it.

Sincerely,



RUSSELL KIEFEL.

**Appendix 5.**  
**Letter from Kerry Walker**

150000  
13-1-00

Dear Russell

I think the

2 chapters you sent me are quite masterly! It brought it all back and I immediately wanted to rehearse the play and perform it again — I think it one of the most important plays written in Andakhi. — ever!

Capturing the essence of a rehearsal and trying to notate it is incredibly difficult and I think you have achieved that — it would be so useful for your direction to read to get an insight into the way he works, <sup>(Neil)</sup> surrounding himself with actors who challenge him. The results are always so remarkably his. Congratulations on the work — good luck with it.

Sincerely  
Kenny

## BIBLIOGRAPHY

- Aaron, Stephen 1986, *Stage Fright*, University of Chicago, Chicago, pp. 5, 24-25, 42, 44, 50, 116, 219-221.
- Armfield, Neil 1998, "Neil's Letter", *The 1998 Company B Book*, pp. 10-11.
- Armfield, Neil 1996, "A letter from Neil Armfield", *The Belvoir Company B Book*, pp. 7.
- Armfield, Neil 1995, "Director's note", *The Blind Giant is Dancing* program.
- Armfield, Neil 1994, A letter to subscribers.
- Barth, Fredrik 1995, "Other Knowledge and Other Ways of Knowing", *Journal of Anthropological Research*, Vol. 51, pp. 65-67.
- Benedetti, Robert 1985, *The Director at Work*, Prentice-Hall, Englewood Cliffs, pp. 5-6, 110, 130.
- Bogart, Anne 1997, "Six things I know about being a theatre artist at the end of the twentieth century", Keynote Speech at *Disorientations*, ADS Conference, July 15 -19, Monash University, Melbourne.
- Bonney, Gabrielle 1994, "Richard Roxburgh Burning Down The House", *Dialogue* , March, pp. 8-9.
- Bonnycastle, Stephen 1996, *In Search of Authority An Introductory Guide to Literary Theory*, Broadview Press, pp. 156.
- Bourdieu, Pierre 1993, *The Field of Cultural Production Pierre Bourdieu on Art, Literature and Culture* , in Randall Johnson (ed), University of Columbia Press, pp. 5-20.
- Bouvier, Helene 1994, "Introduction", *Theatre Research International* (Special Issue: Anthropology and Theatre), XIX, No. 1, pp. 1-2.

- Bradby, David and Williams, David 1988, *Director's Theatre*, MacMillan, London, pp.1-2 & 22-23.
- Brook, Peter 1987, *The Shifting Point*, Methuen Drama, London, pp. 4, 157.
- Brook, Peter 1968, *The Empty Space*, Penguin Book, London, pp. 22, 89, 96, 117.
- Burvill, Tom 1997, "They left the samovar in the cupboard- Observations of the Belvoir/Armfield 'Seagull'," Paper given at the 1997 ADS Conference, *Disorientations*, July 15-19.
- Callow, Simon 1984, *Being An Actor*, St Martin's Press, New York, pp. 110, 160-162, 174-179.
- Charest, Remy 1995, *Robert Lepage Connecting Flights*, Methuen, London, pp. 136-137.
- Clifford, James 1988, *The Predicament of Culture Twentieth Century Ethnography, Literature and Art*, Harvard University Press, pp. 23, 25, 34-35, 38, 43, 50-51, 53-54.
- Clifford, James and Marcus, George E, 1986, *Writing Culture The Poetics and Politics of Ethnography*, University of California Press, pp. 244.
- Cook, Judy 1987, *Directors' Theatre*, Hodder & Stoughton, pp. 92-93.
- Cosic, Miriam 1999, "Boy from Company B", *The Australian Magazine*, Feb. 20-21, pp. 16-23.
- Deleuze, Gilles & Guattari, Felix 1986, *Kafka: Towards a Minor Literature*, University of Minnesota, Minneapolis, pp. 16-27.
- De Marinis, Marco 1985, "A Faithful Betrayal of Performance: Notes on the Use of Video in Theatre", *New Theatre Quarterly*, 1:4, pp. 383-387.
- Farr, David 1997, "Showing the Truth", in David Tushingham (ed), *Live 5 My perfect Theatre*, Nick Hern Books, London, pp. 65-66.
- Finnegan, Ruth 1992, *Oral traditions and the verbal arts - A guide to research practices*, Routledge, pp. 16, 37, 42-43, 62-63, 68.

- Fischer-Lichte, Erica 1983, *The Semiotics Of Theatre* , pp. 216, 224.
- Foucault, Michael 1984, "The Subject and Power", in Brian Wallis (ed), *Art after Modernism: Rethinking Representation*, The Museum of Contemporary Art, New York, pp. 417-432.
- Fortier, Mark 1998, "Thinking process", *Canadian Theatre Review* pp. 8-11.
- Garner Lyn 1997, "Family that plays together", *Guardian Weekly*, Vol 157, No 22, November 30, pp. 26.
- Golder, John & Madelaine, Richard 1995, "Elsinore at Belvoir Street: Neil Armfield talks about Hamlet" (Interview with Neil Armfield), *Australian Drama Studies*, Vol. 26, pp. 55-80.
- Halliday, M.A.K. and Hasan, Ruqaiya 1985, *Language, context and text: Aspects of language in a social-semiotic perspective* Deakin University Press, Victoria, pp. 6-7.
- Hiley, Jim 1981, *Theatre at Work The story of the National Theatre's production of Brecht's Galileo* , Routledge & Kegan Paul Ltd, London.
- Hirst, David 1993, *Giorgio Strehler*, Cambridge University Press, pp. 32.
- Helbo, Pavis, Ubersfeld et al. 1991, *Approaching Theatre*, Indiana UP, pp. 136, 142.
- James, Christopher 1992, Interview with Robert Lepage, *Plays and Players*, July, pp. 14.
- Jordan, Rob & McCallum, John 1995 *Australian and New Zealand Theatre Record* Vols Australian Theatre Studies Centre, University of New South Wales, pp. 6-9.
- Kiernander, Adrien 1993, *Ariane Mnouckhine and the Theatre du Soleil*, Cambridge University Press, pp. 14 & 20.
- Larkin, John 1996, "Stagecraft", *The Australian Way*, Qantas inflight magazine, pp. 12-14.
- LeCoq Jacques 1987, *Le Theatre du Geste*, Bordas, Paris, pp.100-101.
- Letzler Cole, Susan 1992, *Directors in rehearsal: a hidden world*, Routledge, New York, pp. 3, 5, 8, 16, 22.

- Litson, Jo 2000, " Oedipal complexity with a twist", *The Australian*, June 23, pp. 15.
- Litson, Jo (ed) 1999/2000, 'News Extra - Overseas raves', *Artforce* (Australia Council Newsletter), Sydney, pp.17.
- Litson, Jo 1995, "Theatre stage, Interview with Neil Armfield", *Vogue*, May, pp. 80.
- Lowen, Tirzah 1990, *Peter Hall Directs Anthony and Cleopatra* Methuen Drama, London, pp. 22.
- McAuley, Gay 1996, "Theatre practice and critical theory" *Australian Drama Studies* , 28 (April 1996), pp. 140-145.
- McAuley, Gay 1998, "Towards an Ethnography of Rehearsal", *New Theatre Quarterly*, pp. 75-84.
- Melzer, Annabelle 1995, "'Best Betrayal': the Documentation of Performance on Video and Film, Part 1", *New Theatre Quarterly*, 42, May, pp. 147-148, 150, 152-153.
- Melzer, Annabelle 1997, "'Best Betrayal': the Documentation of Performance on Video and Film, Part 2", *New Theatre Quarterly*, pp. 262-265.
- Miles, Patrick 1991, "Chekhov, Shakespeare, the Ensemble and the Company, Interview with Peter Hall", *New Theatre Quarterly*, pp. 204-205.
- Minchinton, Mark 1998, "The right and only direction: Rex Cramphorn and the Actors' Development Stream", *Australasian Drama Studies*, Vol. 33, pp. 128-143.
- Nowra, Louis 1988, "Neil Armfield - Radical Classicist", *New Theatre*.
- Okely, Judith & Calloway, Helen 1992, *Anthropology and Autobiography* , Routledge, London, pp. 6, 9, 13-14, 32, 117, 119, 121-123, 125-126.
- Parsons, Phillip (ed) 1995, *Companion to Theatre in Australia* , Currency Press, Sydney, pp 218, 407.
- Pavis, Patrice 1992, *Theatre at the Crossroads of Culture* Routledge, London, pp. 9, 15, 21.
- Pavis, Patrice 1998, *Dictionary of the Theatre Terms, Concepts and Analysis*, University of Toronto, pp. 63, 103, 163-164.

- Phillips, Bill 1996, "Neil Armfield, Interview with Neil Armfield", *Campaign* , April, pp. 32-33.
- Piscator, Erwin 1980, *Erwin Piscator The Political Theatre*, Eyre Methuen, London, pp. 133.
- Radic, Leonard 1991, *The State of Play The Revolution in the Australian Theatre since the 1960s* , Penguin Books, pp. 4-6, 182-183.
- Ratcliffe, Michael 1995, Introduction in *Theatre de Complicite, The Three Lives of Lucie Cabrol*, Methuen Drama, London.
- Ridgman, Jeremy 1983, "Louis Nowra, Stephen Sewell and Neil Armfield talk to Jeremy Ridgman", *Australian Drama Studies*, Vol. 26, pp. 105-123.
- Rowse, Tim 1985, *Arguing the Arts*, Penguin Books, pp. 70.
- Sewell, Stephen 1983, *The Blind Giant is Dancing*, Currency Press, Melbourne.
- Sharman, Jim 1995, "In the Realm of the Imagination" (Rex Cramphorn Memorial Lecture) *The Sydney Review* , pp. 10-12.
- Sher, Anthony 1985, *Year of the King: An Actor's Diary and Sketchbook*, Chatto & Windus, London, pp. 211.
- Stewart, Meg 1995, "Neil Armfield Director" (Interview with Neil Armfield), *Sydney Morning Herald*, Dec 13, pp. 16.
- Stewart, Meg 1995. "Cate Blanchett", (Interview with Cate Blanchett), *Sydney Morning Herald*, July 26, pp. 18.
- Tedlock, Barbara 1991, "From Participant Observation to the Observation of Participation: The Emergence of Narrative Ethnography", *Journal of Anthropological Research* , Vol 47, no.1, pp. 69-85.
- Turner, Victor 1975, Introduction in Jules-Rosette, B., *African Apostles: Ritual and Conversion in the Church of John Maranke*, Ithaca, Cornell University Press, New York, pp. 8.
- Tyler, Stephen 1987, *The Unspeakable Discourse , Dialogue and Rhetoric in the Postmodern World*, University of Wisconsin Press, pp. 101.

- Waites, James 1987, "Alternative Shakespeare: Rex Cramphorn",  
in Richard Fotheringham (ed), *Community Theatre in  
Australia*, Methuen Australia, Sydney, pp. 188.
- Waites, James 1994, *Sydney Morning Herald*, Nov 23, pp 23.
- Willett, John (ed) 1964, *Brecht on Theatre*, Methuen, London,  
pp. 104, 109.
- Williams, Raymond 1982, *Towards a Sociology of Culture*,  
Schocken Books, New York, pp. 13.

X

UNIVERSITY OF SYDNEY LIBRARY



000000608730485

RARE BOOKS LIB